

CODICE - CODE		descrizione description	DIMENSIONI PRINCIPALI - MAIN DIMENSIONS							CARICO STATICO STATIC LOAD NEWTON
standard standard	cataforesi nero black cathaphoresis		S	B	D		F	G	H	
15600Z	15602C	M16X100	4	100	124	17	M16	20,5	134	20000
15604Z	15606C	M16X150	4	150	124	17	M16	20,5	184	20000
15608Z	15610C	M16X175	4	175	124	17	M16	20,5	209	20000
15612Z	15614C	M20X100	4	100	124	17	M20	20,5	134	25000
15616Z	15618C	M20X150	4	150	124	17	M20	20,5	184	25000
15620Z	15622C	M20X175	4	175	124	17	M20	20,5	209	25000
15624Z	15626C	M20X200	4	200	124	17	M20	20,5	234	25000
15628Z	15630C	M24X100	4	100	124	20	M24	20,5	134	30000
15632Z	15634C	M24X150	4	150	124	20	M24	20,5	184	30000
15636Z	15638C	M24X200	4	200	124	20	M24	20,5	234	30000
15640Z	15642C	M30X150	4	150	124	26	M30	20,5	185	35000
15644Z	15646C	M30X200	4	200	124	26	M30	20,5	235	35000
15648Z	15650C	M30X250	4	250	124	26	M30	20,5	285	35000

Caratteristiche: BASE Ø 124 CON 4 FORI, STELO SNODATO 8° O FISSO CON DADO

Features: BASE Ø 124 WITH 4 BORES, 8° ARTICULATED STEM OR FIX BY BOTTOM LOCKING NUT

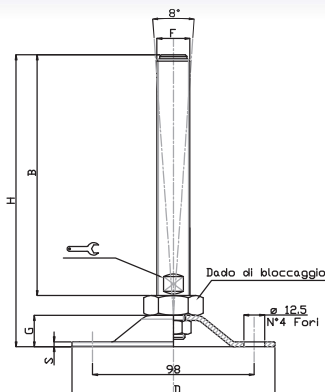

CODICE - CODE		descrizione description	DIMENSIONI PRINCIPALI - MAIN DIMENSIONS							CARICO STATICO STATIC LOAD NEWTON
S	B		D		F	G	H			
15604Z/FIX	M16X150	4	150	124	17	M16	20,5	184	20000	
15611Z/FIX	M16X200	4	200	124	17	M16	20,5	234	20000	
15616Z/FIX	M20X150	4	150	124	17	M20	20,5	184	25000	
15624Z/FIX	M20X200	4	200	124	17	M20	20,5	234	25000	
15632Z/FIX	M24X150	4	150	124	20	M24	20,5	184	30000	
15636Z/FIX	M24X200	4	200	124	20	M24	20,5	234	30000	

• Base stampata in acciaio zincato FE o cataforesi nera. Il trattamento di cataforesi della base garantisce un'ottima resistenza all'aggressione di solventi, sgrassanti chimici e lavaggi industriali. Stelo acciaio zincato FE. Su richiesta l'elemento di livellamento viene fornito con dado in acciaio

• Material: pressed base in galvanized steel or black cathaphoresis. The cathaphoresis treatment of the surface grants an excellent resistance against solvents and chemical agents. Galvanized steel screw. The levelling element could be supplied with steel nut.