

CODICE - CODE		descrizione description	DIMENSIONI PRINCIPALI - MAIN DIMENSIONS							CARICO STATICO STATIC LOAD NEWTON
standard standard	antiscivolo antislip		A	B	D	⬡	F	H	H1	
9100	9101	M8X25	16	25	Ø40	4	M8	41	44	5000
9110	9111	M8X50	16	50	Ø40	4	M8	66	69	5000
9120	9121	M10X25	16	25	Ø40	5	M10	41	44	5000
9130	9131	M10X50	16	50	Ø40	5	M10	66	69	5000
9140	9141	M8X25	20	25	Ø50	4	M8	45	48	6000
9150	9151	M8X50	20	50	Ø50	4	M8	70	73	6000
9160	9161	M10X25	20	25	Ø50	5	M10	45	48	6000
9170	9171	M10X50	20	50	Ø50	5	M10	70	73	6000

Confezione:

- per articoli con base Ø 40 mm: 200 pezzi
- per articoli con base Ø 50 mm: 150 pezzi

Set Box:

- Products Ø 40 mm base: 200 pieces
- Products Ø 50 mm base: 150 pieces

- Materiale base: poliammide rinforzato con fibra di vetro. A richiesta disponibile con gomma antiscivolo NBR 70 shore (codice standard = senza gomma). Materiale stelo: acciaio zincato FE. Su richiesta l'elemento di livellamento viene fornito con dado in acciaio.
- I valori dei carichi sopra riportati sono calcolati in condizioni statiche alla metà della lunghezza dello stelo filettato. Qualora s'intendesse utilizzare i supporti in presenza di vibrazioni o carichi in movimento, tali valori dovranno essere adeguatamente ridotti. Per ulteriori chiarimenti consultare il nostro ufficio tecnico. Ogni nostra responsabilità decade in caso di manomissioni o modifiche dei componenti.
- Base in black polyamide material, reinforced by fiber glass. On request non-skid plate in NBR rubber 70 shore is available (Standard code = without rubber). Galvanized steel screw. The leveling element could be supplied, on request, with steel nut.
- Load values above mentioned have to be considered referring to static conditions calculated at the half of the screw length. In conditions of vibrations or in presence of dynamic loads these values should be reduced. For further information consult our technical office. We cannot accept responsibility for mounts that have been tampered or modified.

Piede in Polyamide & Acciaio Zincato

PLASTICA

Martin
Levelling Components

PLASTICA

Caratteristiche: BASE Ø 40, STELO SNODATO 30°

Features: BASE Ø 40, 30° ARTICULATED STEM

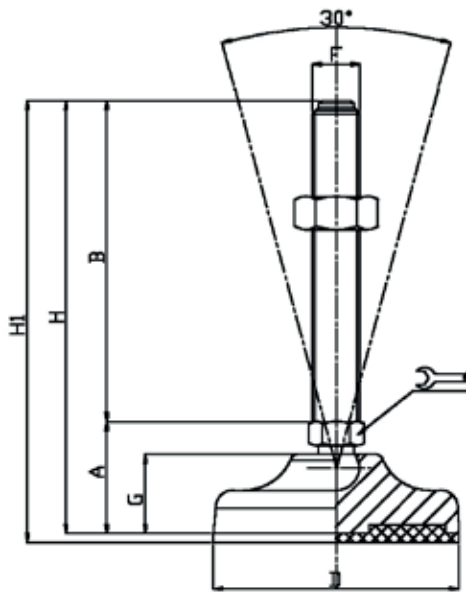

CODICE - CODE		descrizione description	DIMENSIONI PRINCIPALI - MAIN DIMENSIONS								CARICO STATICO STATIC LOAD NEWTON
standard standard	antiscivolo antislip		A	B	D		F	G	H	H1	
10220/6	10221/6	M6X25	27	25	Ø 40	12	M6	16,5	52	55	5000
10222/6	10223/6	M6X50	27	50	Ø 40	12	M6	16,5	77	80	5000
10224/6	10225/6	M6X75	27	75	Ø 40	12	M6	16,5	102	105	5000
10220	10221	M8X25	27	25	Ø 40	12	M8	16,5	52	55	10000
10222	10223	M8X50	27	50	Ø 40	12	M8	16,5	77	80	10000
10224	10225	M8X75	27	75	Ø 40	12	M8	16,5	102	105	10000
10226	10227	M8X100	27	100	Ø 40	12	M8	16,5	127	130	10000
10228	10229	M10X25	27	25	Ø 40	12	M10	16,5	52	55	10000
10230	10231	M10X50	27	50	Ø 40	12	M10	16,5	77	80	10000
10232	10233	M10X75	27	75	Ø 40	12	M10	16,5	102	105	10000
10234	10235	M10X100	27	100	Ø 40	12	M10	16,5	127	130	10000
10236	10237	M10X125	27	125	Ø 40	12	M10	16,5	152	155	10000
10228/12	10229/12	M12X25	27	25	Ø 40	12	M12	16,5	52	55	10000
10230/12	10231/12	M12X50	27	50	Ø 40	12	M12	16,5	77	80	10000
10232/12	10233/12	M12X75	27	75	Ø 40	12	M12	16,5	102	105	10000
10234/12	10235/12	M12X100	27	100	Ø 40	12	M12	16,5	127	130	10000
10236/12	10237/12	M12X125	27	125	Ø 40	12	M12	16,5	152	155	10000

• Materiale base: poliammide rinforzato con fibra di vetro. A richiesta disponibile con gomma antiscivolo NBR 70 shore (codice standard = senza gomma). Materiale stelo: acciaio zincato FE. Su richiesta l'elemento di livellamento viene fornito con dado in acciaio.

• I valori dei carichi sopra riportati sono calcolati in condizioni statiche alla metà della lunghezza dello stelo filettato. Qualora s'intendesse utilizzare i supporti in presenza di vibrazioni o carichi in movimento, tali valori dovranno essere adeguatamente ridotti. Per ulteriori chiarimenti consultare il nostro ufficio tecnico. Ogni nostra responsabilità decade in caso di manomissioni o modifiche dei componenti.

• Base in black polyamide material, reinforced by fiber glass. On request non-skid plate in NBR rubber 70 shore is available (Standard code = without rubber). Galvanized steel screw. The leveling element could be supplied, on request, with steel nut.

• Load values above mentioned have to be considered referring to static conditions calculated at the half of the screw length. In conditions of vibrations or in presence of dynamic loads these values should be reduced. For further information consult our technical office. We cannot accept responsibility for mounts that have been tampered or modified.

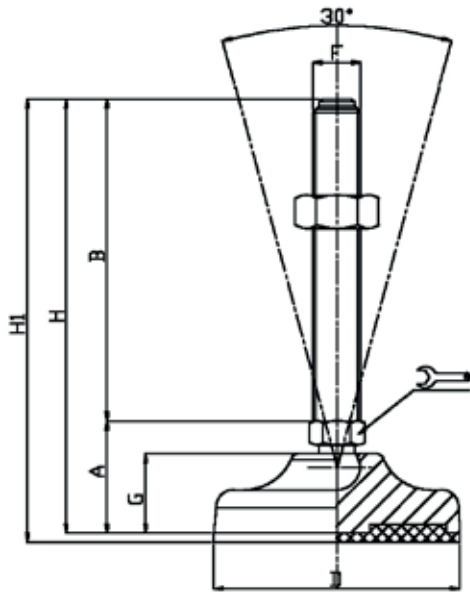

CODICE - CODE		descrizione description	DIMENSIONI PRINCIPALI - MAIN DIMENSIONS								CARICO STATICO STATIC LOAD NEWTON
standard standard	antiscivolo antislip		A	B	D		F	G	H	H1	
10238	10239	M10X25	30	25	Ø 50	14	M10	20	55	58	11000
10240	10241	M10X50	30	50	Ø 50	14	M10	20	80	83	11000
10242	10243	M10X75	30	75	Ø 50	14	M10	20	105	108	11000
10244	10245	M10X100	30	100	Ø 50	14	M10	20	130	133	11000
10246	10247	M10X125	30	125	Ø 50	14	M10	20	155	158	11000
10248	10249	M12X25	30	25	Ø 50	14	M12	20	55	58	11000
10250	10251	M12X50	30	50	Ø 50	14	M12	20	80	83	11000
10252	10253	M12X75	30	75	Ø 50	14	M12	20	105	108	11000
10254	10255	M12X100	30	100	Ø 50	14	M12	20	130	133	11000
10256	10257	M12X125	30	125	Ø 50	14	M12	20	155	158	11000
10258	10259	M14X25	30	25	Ø 50	14	M14	20	55	58	11000
10260	10261	M14X50	30	50	Ø 50	14	M14	20	80	83	11000
10262	10263	M14X75	30	75	Ø 50	14	M14	20	105	108	11000
10264	10265	M14X100	30	100	Ø 50	14	M14	20	130	133	11000
10266	10267	M14X125	30	125	Ø 50	14	M14	20	155	158	11000
10260/16	10261/16	M16X50	30	50	Ø 50	16	M16	20	80	83	11000
10262/16	10263/16	M16X75	30	75	Ø 50	16	M16	20	105	108	11000
10264/16	10265/16	M16X100	30	100	Ø 50	16	M16	20	130	133	11000
10266/16	10267/16	M16X125	30	125	Ø 50	16	M16	20	155	158	11000
10268/16	10269/16	M16X150	30	150	Ø 50	16	M16	20	180	183	11000

• Materiale base: poliammide rinforzato con fibra di vetro. A richiesta disponibile con gomma antiscivolo NBR 70 shore (codice standard = senza gomma). Materiale stelo: acciaio zincato FE. Su richiesta l'elemento di livellamento viene fornito con dado in acciaio.

• I valori dei carichi sopra riportati sono calcolati in condizioni statiche alla metà della lunghezza dello stelo filettato. Qualora s'intendesse utilizzare i supporti in presenza di vibrazioni o carichi in movimento, tali valori dovranno essere adeguatamente ridotti. Per ulteriori chiarimenti consultare il nostro ufficio tecnico. Ogni nostra responsabilità decade in caso di manomissioni o modifiche dei componenti.

• Base in black polyamide material, reinforced by fiber glass. On request non-skid plate in NBR rubber 70 shore is available (Standard code = without rubber). Galvanized steel screw. The leveling element could be supplied, on request, with steel nut.

• Load values above mentioned have to be considered referring to static conditions calculated at the half of the screw length. In conditions of vibrations or in presence of dynamic loads these values should be reduced. For further information consult our technical office. We cannot accept responsibility for mounts that have been tampered or modified.

Piede in Polyamide & Acciaio Zincato

PLASTICA

Martin
Levelling Components

PLASTICA

Caratteristiche: BASE Ø 65, STELO SNODATO 30°

Features: BASE Ø 65, 30° ARTICULATED STEM

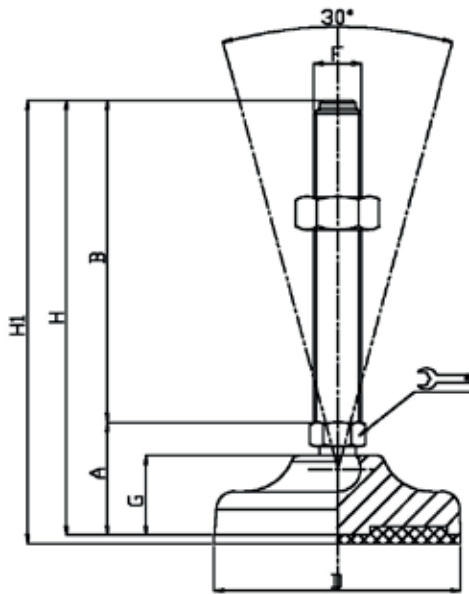

CODICE - CODE		descrizione description	DIMENSIONI PRINCIPALI - MAIN DIMENSIONS								CARICO STATICO STATIC LOAD NEWTON
standard standard	antiscivolo antislip		A	B	D		F	G	H	H1	
10268/10	10269/10	M10X50	33	50	Ø 65	14	M10	23	83	86	11000
10270/10	10271/10	M10X75	33	75	Ø 65	14	M10	23	108	111	11000
10272/10	10273/10	M10X100	33	100	Ø 65	14	M10	23	133	136	11000
10274/10	10275/10	M10X125	33	125	Ø 65	14	M10	23	158	161	11000
10268/12	10269/12	M12X50	33	50	Ø 65	14	M12	23	83	86	11000
10270/12	10271/12	M12X75	33	75	Ø 65	14	M12	23	108	111	11000
10272/12	10273/12	M12X100	33	100	Ø 65	14	M12	23	133	136	11000
10274/12	10275/12	M12X125	33	125	Ø 65	14	M12	23	158	161	11000
10268	10269	M14X50	33	50	Ø 65	14	M14	23	83	86	15000
10270	10271	M14X75	33	75	Ø 65	14	M14	23	108	111	15000
10272	10273	M14X100	33	100	Ø 65	14	M14	23	133	136	15000
10274	10275	M14X125	33	125	Ø 65	14	M14	23	158	161	15000
10276	10277	M14X150	33	150	Ø 65	14	M14	23	183	186	15000
10278	10279	M14X175	33	175	Ø 65	14	M14	23	208	211	15000

• Materiale base: poliammide rinforzato con fibra di vetro. A richiesta disponibile con gomma antiscivolo NBR 70 shore (codice standard = senza gomma). Materiale stelo: acciaio zincato FE. Su richiesta l'elemento di livellamento viene fornito con dado in acciaio.

• I valori dei carichi sopra riportati sono calcolati in condizioni statiche alla metà della lunghezza dello stelo filettato. Qualora s'intendesse utilizzare i supporti in presenza di vibrazioni o carichi in movimento, tali valori dovranno essere adeguatamente ridotti. Per ulteriori chiarimenti consultare il nostro ufficio tecnico. Ogni nostra responsabilità decade in caso di manomissioni o modifiche dei componenti.

• Base in black polyamide material, reinforced by fiber glass. On request non-skid plate in NBR rubber 70 shore is available (Standard code = without rubber). Galvanized steel screw. The leveling element could be supplied, on request, with steel nut.

• Load values above mentioned have to be considered referring to static conditions calculated at the half of the screw length. In conditions of vibrations or in presence of dynamic loads these values should be reduced. For further information consult our technical office. We cannot accept responsibility for mounts that have been tampered or modified.

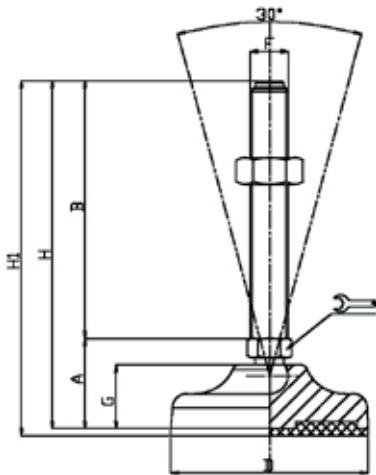

CODICE - CODE		descrizione description	DIMENSIONI PRINCIPALI - MAIN DIMENSIONS								CARICO STATICO STATIC LOAD NEWTON
standard standard	antiscivolo antislip		A	B	D		F	G	H	H1	
10280	10281	M16X50	33	50	Ø 65	16	M16	23	83	86	15000
10282	10283	M16X75	33	75	Ø 65	16	M16	23	108	111	15000
10284	10285	M16X100	33	100	Ø 65	16	M16	23	133	136	15000
10286	10287	M16X125	33	125	Ø 65	16	M16	23	158	161	15000
10288	10289	M16X150	33	150	Ø 65	16	M16	23	183	186	15000
10290	10291	M16X175	33	175	Ø 65	16	M16	23	208	211	15000
10292	10293	M16X200	33	200	Ø 65	16	M16	23	233	236	15000

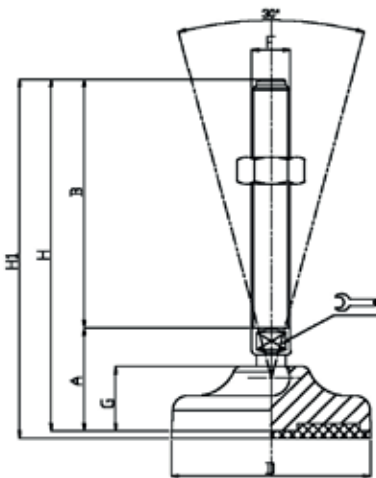

CODICE - CODE		descrizione description	DIMENSIONI PRINCIPALI - MAIN DIMENSIONS								CARICO STATICO STATIC LOAD NEWTON
standard standard	antiscivolo antislip		A	B	D		F	G	H	H1	
10282/20	10283/20	M20X75	37	75	Ø 65	17	M20	23	112	115	15000
10284/20	10285/20	M20X100	37	100	Ø 65	17	M20	23	137	140	15000
10286/20	10287/20	M20X125	37	125	Ø 65	17	M20	23	162	165	15000
10288/20	10289/20	M20X150	37	150	Ø 65	17	M20	23	187	190	15000
10290/20	10291/20	M20X175	37	175	Ø 65	17	M20	23	212	215	15000
10292/20	10293/20	M20X200	37	200	Ø 65	17	M20	23	237	240	15000

• Materiale base: poliammide rinforzato con fibra di vetro. A richiesta disponibile con gomma antiscivolo NBR 70 shore (codice standard = senza gomma). Materiale stelo: acciaio zincato FE. Su richiesta l'elemento di livellamento viene fornito con dado in acciaio.

• Base in black polyamide material, reinforced by fiber glass. On request non-skid plate in NBR rubber 70 shore is available (Standard code = without rubber). Galvanized steel screw. The leveling element could be supplied, on request, with steel nut.

Piede in Polyamide & Acciaio Zincato

PLASTICA

Martin
Levelling Components

PLASTICA

Caratteristiche: BASE Ø 83, STELO SNODATO 30°

Features: BASE Ø 83, 30° ARTICULATED STEM

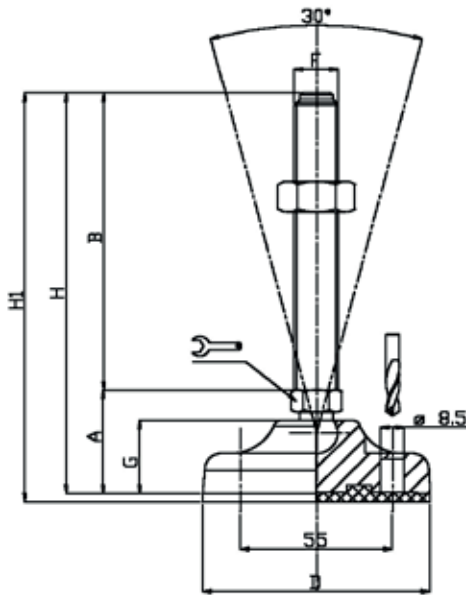

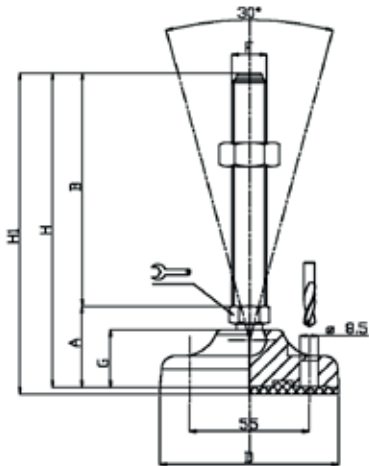

CODICE - CODE		descrizione description	DIMENSIONI PRINCIPALI - MAIN DIMENSIONS								CARICO STATICO STATIC LOAD NEWTON
standard standard	antiscivolo antislip		A	B	D		F	G	H	H1	
10294/10	10295/10	M10X50	38	50	Ø 83	14	M10	27	88	91	15000
10296/10	10297/10	M10X75	38	75	Ø 83	14	M10	27	113	116	15000
10298/10	10299/10	M10X100	38	100	Ø 83	14	M10	27	138	141	15000
10300/10	10301/10	M10X125	38	125	Ø 83	14	M10	27	163	166	15000
10294/12	10295/12	M12X50	38	50	Ø 83	14	M12	27	88	91	15000
10296/12	10297/12	M12X75	38	75	Ø 83	14	M12	27	113	116	15000
10298/12	10299/12	M12X100	38	100	Ø 83	14	M12	27	138	141	15000
10300/12	10301/12	M12X125	38	125	Ø 83	14	M12	27	163	166	15000
10294/14	10295/14	M14X50	38	50	Ø 83	14	M14	27	88	91	20000
10296/14	10297/14	M14X75	38	75	Ø 83	14	M14	27	113	116	20000
10298/14	10299/14	M14X100	38	100	Ø 83	14	M14	27	138	141	20000
10300/14	10301/14	M14X125	38	125	Ø 83	14	M14	27	163	166	20000
10302/14	10303/14	M14X150	38	150	Ø 83	14	M14	27	188	191	20000
10304/14	10305/14	M14X175	38	175	Ø 83	14	M14	27	213	216	20000

- Materiale base: poliammide rinforzato con fibra di vetro. A richiesta disponibile con gomma antiscivolo NBR 70 shore (codice standard = senza gomma). Materiale stelo: acciaio zincato FE. Su richiesta l'elemento di livellamento viene fornito con dado in acciaio.
- I valori dei carichi sopra riportati sono calcolati in condizioni statiche alla metà della lunghezza dello stelo filettato. Qualora s'intendesse utilizzare i supporti in presenza di vibrazioni o carichi in movimento, tali valori dovranno essere adeguatamente ridotti. Per ulteriori chiarimenti consultare il nostro ufficio tecnico. Ogni nostra responsabilità decade in caso di manomissioni o modifiche dei componenti.
- Base in black polyamide material, reinforced by fiber glass. On request non-skid plate in NBR rubber 70 shore is available (Standard code = without rubber). Galvanized steel screw. The leveling element could be supplied, on request, with steel nut.
- Load values above mentioned have to be considered referring to static conditions calculated at the half of the screw length. In conditions of vibrations or in presence of dynamic loads these values should be reduced. For further information consult our technical office. We cannot accept responsibility for mounts that have been tampered or modified.

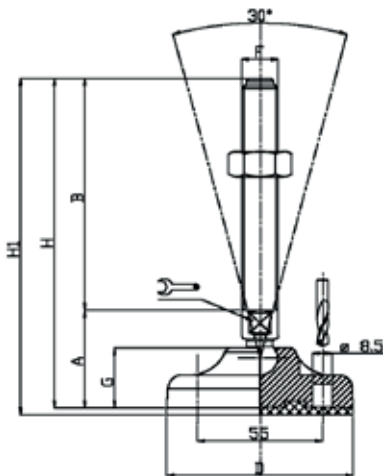

CODICE - CODE		descrizione description	DIMENSIONI PRINCIPALI - MAIN DIMENSIONS								CARICO STATICO STATIC LOAD NEWTON
standard standard	antiscivolo antislip		A	B	D		F	G	H	H1	
10294	10295	M16X50	38	50	Ø 83	16	M16	27	88	91	20000
10296	10297	M16X75	38	75	Ø 83	16	M16	27	113	116	20000
10298	10299	M16X100	38	100	Ø 83	16	M16	27	138	141	20000
10300	10301	M16X125	38	125	Ø 83	16	M16	27	163	166	20000
10302	10303	M16X150	38	150	Ø 83	16	M16	27	188	191	20000
10304	10305	M16X175	38	175	Ø 83	16	M16	27	213	216	20000
10306	10307	M16X200	38	200	Ø 83	16	M16	27	238	241	20000



CODICE - CODE		descrizione description	DIMENSIONI PRINCIPALI - MAIN DIMENSIONS								CARICO STATICO STATIC LOAD NEWTON
standard standard	antiscivolo antislip		A	B	D		F	G	H	H1	
10308	10309	M20X75	41	75	Ø 83	17	M20	27	116	119	20000
10310	10311	M20X100	41	100	Ø 83	17	M20	27	141	144	20000
10312	10313	M20X125	41	125	Ø 83	17	M20	27	166	169	20000
10314	10315	M20X150	41	150	Ø 83	17	M20	27	191	194	20000
10316	10317	M20X175	41	175	Ø 83	17	M20	27	216	219	20000
10318	10319	M20X200	41	200	Ø 83	17	M20	27	241	244	20000
10320	10321	M20X225	41	225	Ø 83	17	M20	27	266	269	20000

• Materiale base: poliammide rinforzato con fibra di vetro. A richiesta disponibile con gomma antiscivolo NBR 70 shore (codice standard = senza gomma). Materiale stelo: acciaio zincato FE. Su richiesta l'elemento di livellamento viene fornito con dado in acciaio.

• Base in black polyamide material, reinforced by fiber glass. On request non-skid plate in NBR rubber 70 shore is available (Standard code = without rubber). Galvanized steel screw. The leveling element could be supplied, on request, with steel nut.

Piede in Polyamide & Acciaio Zincato

Caratteristiche: BASE Ø 103, STELO SNODATO 30°

Features: BASE Ø 103, 30° ARTICULATED STEM

PLASTICA

Martin
Levelling Components

PLASTICA

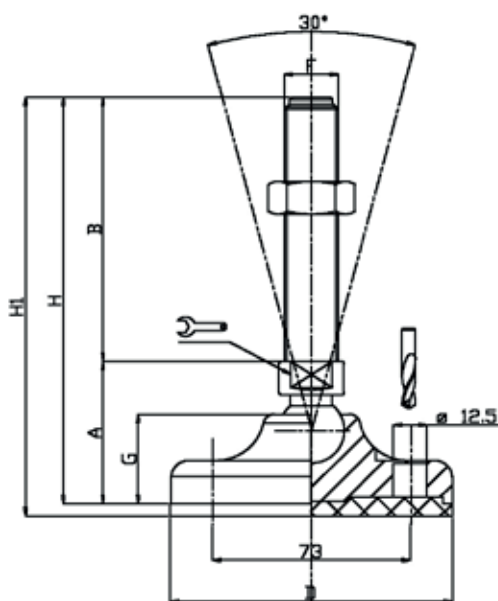

CODICE - CODE		descrizione description	DIMENSIONI PRINCIPALI - MAIN DIMENSIONS								CARICO STATICO STATIC LOAD NEWTON
standard standard	antiscivolo antislip		A	B	D		F	G	H	H1	
10322	10323	M16X50	51	50	Ø 103	20	M16	32	101	104	25000
10324	10325	M16X75	51	75	Ø 103	20	M16	32	126	129	25000
10326	10327	M16X100	51	100	Ø 103	20	M16	32	151	154	25000
10328	10329	M16X125	51	125	Ø 103	20	M16	32	176	179	25000
10330	10331	M16X150	51	150	Ø 103	20	M16	32	201	204	25000
10332	10333	M16X175	51	175	Ø 103	20	M16	32	226	229	25000
10334	10335	M16X200	51	200	Ø 103	20	M16	32	251	254	25000
10336	10337	M16X225	51	225	Ø 103	20	M16	32	276	279	25000
10340	10341	M20X75	51	75	Ø 103	20	M20	32	126	129	25000
10342	10343	M20X100	51	100	Ø 103	20	M20	32	151	154	25000
10344	10345	M20X125	51	125	Ø 103	20	M20	32	176	179	25000
10346	10347	M20X150	51	150	Ø 103	20	M20	32	201	204	25000
10348	10349	M20X175	51	175	Ø 103	20	M20	32	226	229	25000
10350	10351	M20X200	51	200	Ø 103	20	M20	32	251	254	25000
10352	10353	M20X225	51	225	Ø 103	20	M20	32	276	279	25000
10354	10355	M20X250	51	250	Ø 103	20	M20	32	301	304	25000
10358	10359	M24X75	51	75	Ø 103	20	M24	32	126	129	25000
10360	10361	M24X100	51	100	Ø 103	20	M24	32	151	154	25000
10362	10363	M24X125	51	125	Ø 103	20	M24	32	176	179	25000
* 10364	10365	M24X150	51	150	Ø 103	20	M24	32	201	204	25000
* 10366	10367	M24X175	51	175	Ø 103	20	M24	32	226	229	25000
* 10368	10369	M24X200	51	200	Ø 103	20	M24	32	251	254	25000
10370	10371	M24X225	51	225	Ø 103	20	M24	32	276	279	25000
10372	10373	M24X250	51	250	Ø 103	20	M24	32	301	304	25000

* Disponibile con Filettatura a passo fine. Aggiungere "/P2" al codice
Available with Thin pitch thread. Please, add "/P2" to the code

• Materiale base: poliammide rinforzato con fibra di vetro. A richiesta disponibile con gomma antiscivolo NBR 70 shore (codice standard = senza gomma). Materiale stelo: acciaio zincato FE. Su richiesta l'elemento di livellamento viene fornito con dado in acciaio.

• I valori dei carichi sopra riportati sono calcolati in condizioni statiche alla metà della lunghezza dello stelo filettato. Qualora s'intendesse utilizzare i supporti in presenza di vibrazioni o carichi in movimento, tali valori dovranno essere adeguatamente ridotti. Per ulteriori chiarimenti consultare il nostro ufficio tecnico. Ogni nostra responsabilità decade in caso di manomissioni o modifiche dei componenti.

• Base in black polyamide material, reinforced by fiber glass. On request non-skid plate in NBR rubber 70 shore is available (Standard code = without rubber). Galvanized steel screw. The leveling element could be supplied, on request, with steel nut.

• Load values above mentioned have to be considered referring to static conditions calculated at the half of the screw length. In conditions of vibrations or in presence of dynamic loads these values should be reduced. For further information consult our technical office. We cannot accept responsibility for mounts that have been tampered or modified.

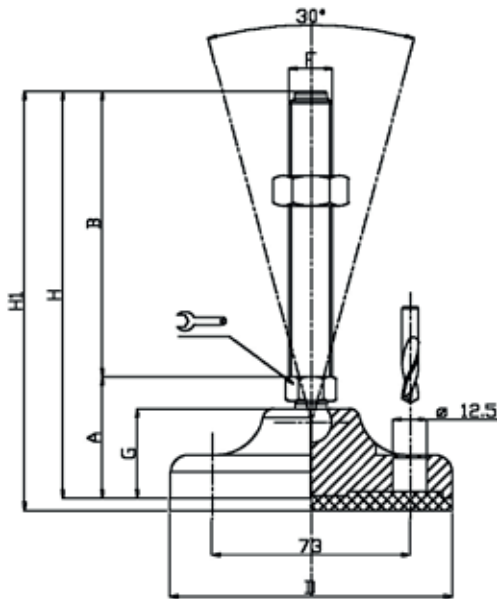

CODICE - CODE		descrizione description	DIMENSIONI PRINCIPALI - MAIN DIMENSIONS								CARICO STATICO STATIC LOAD NEWTON
standard standard	antiscivolo antislip		A	B	D		F	G	H	H1	
10322/15	10323/15	M16X50	51	50	Ø 103	16	M16	32	101	104	20000
10326/15	10327/15	M16X100	51	100	Ø 103	16	M16	32	151	154	20000
10330/15	10331/15	M16X150	51	150	Ø 103	16	M16	32	201	204	20000
10334/15	10335/15	M16X200	51	200	Ø 103	16	M16	32	251	254	20000
10342/20	10343/20	M20X100	51	100	Ø 103	17	M20	32	151	154	20000
10346/20	10347/20	M20X150	51	150	Ø 103	17	M20	32	201	204	20000
10350/20	10351/20	M20X200	51	200	Ø 103	17	M20	32	251	254	20000

- Materiale base: poliammide rinforzato con fibra di vetro. A richiesta disponibile con gomma antiscivolo NBR 70 shore (codice standard = senza gomma). Materiale stelo: acciaio zincato FE. Su richiesta l'elemento di livellamento viene fornito con dado in acciaio.
- I valori dei carichi sopra riportati sono calcolati in condizioni statiche alla metà della lunghezza dello stelo filettato. Qualora s'intendesse utilizzare i supporti in presenza di vibrazioni o carichi in movimento, tali valori dovranno essere adeguatamente ridotti. Per ulteriori chiarimenti consultare il nostro ufficio tecnico. Ogni nostra responsabilità decade in caso di manomissioni o modifiche dei componenti.
- Base in black polyamide material, reinforced by fiber glass. On request non-skid plate in NBR rubber 70 shore is available (Standard code = without rubber). Galvanized steel screw. The leveling element could be supplied, on request, with steel nut.
- Load values above mentioned have to be considered referring to static conditions calculated at the half of the screw length. In conditions of vibrations or in presence of dynamic loads these values should be reduced. For further information consult our technical office. We cannot accept responsibility for mounts that have been tampered or modified.

Piede in Polyamide & Acciaio Zincato

Caratteristiche: BASE Ø 123, STELO SNODATO 30°

Features: BASE Ø 123, 30° ARTICULATED STEM

PLASTICA

Martin
Levelling Components

PLASTICA

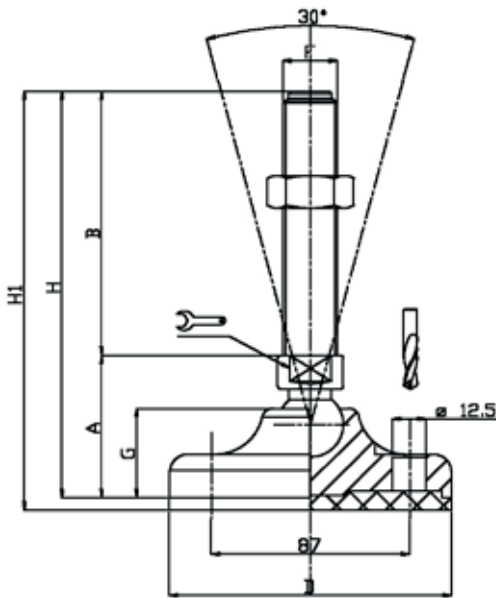

CODICE - CODE		descrizione description	DIMENSIONI PRINCIPALI - MAIN DIMENSIONS								CARICO STATICO STATIC LOAD NEWTON
standard standard	antiscivolo antislip		A	B	D		F	G	H	H1	
10374	10375	M16X50	57	50	Ø 123	20	M16	37	107	110	35000
10376	10377	M16X75	57	75	Ø 123	20	M16	37	132	135	35000
10378	10379	M16X100	57	100	Ø 123	20	M16	37	157	160	35000
10380	10381	M16X125	57	125	Ø 123	20	M16	37	182	185	35000
10382	10383	M16X150	57	150	Ø 123	20	M16	37	207	210	35000
10384	10385	M16X175	57	175	Ø 123	20	M16	37	232	235	35000
10386	10387	M16X200	57	200	Ø 123	20	M16	37	257	260	35000
10388	10389	M16X225	57	225	Ø 123	20	M16	37	285	288	35000
10392	10393	M20X75	57	75	Ø 123	20	M20	37	132	135	35000
10394	10395	M20X100	57	100	Ø 123	20	M20	37	157	160	35000
10396	10397	M20X125	57	125	Ø 123	20	M20	37	182	185	35000
10398	10399	M20X150	57	150	Ø 123	20	M20	37	207	210	35000
10400	10401	M20X175	57	175	Ø 123	20	M20	37	232	235	35000
10402	10403	M20X200	57	200	Ø 123	20	M20	37	257	260	35000
10404	10405	M20X225	57	225	Ø 123	20	M20	37	282	285	35000
10406	10407	M20X250	57	250	Ø 123	20	M20	37	307	310	35000

• Materiale base: poliammide rinforzato con fibra di vetro. A richiesta disponibile con gomma antiscivolo NBR 70 shore (codice standard = senza gomma). Materiale stelo: acciaio zincato FE. Su richiesta l'elemento di livellamento viene fornito con dado in acciaio.

• I valori dei carichi sopra riportati sono calcolati in condizioni statiche alla metà della lunghezza dello stelo filettato. Qualora s'intendesse utilizzare i supporti in presenza di vibrazioni o carichi in movimento, tali valori dovranno essere adeguatamente ridotti. Per ulteriori chiarimenti consultare il nostro ufficio tecnico. Ogni nostra responsabilità decade in caso di manomissioni o modifiche dei componenti.

• Base in black polyamide material, reinforced by fiber glass. On request non-skid plate in NBR rubber 70 shore is available (Standard code = without rubber). Galvanized steel screw. The leveling element could be supplied, on request, with steel nut.

• Load values above mentioned have to be considered referring to static conditions calculated at the half of the screw length. In conditions of vibrations or in presence of dynamic loads these values should be reduced. For further information consult our technical office. We cannot accept responsibility for mounts that have been tampered or modified.

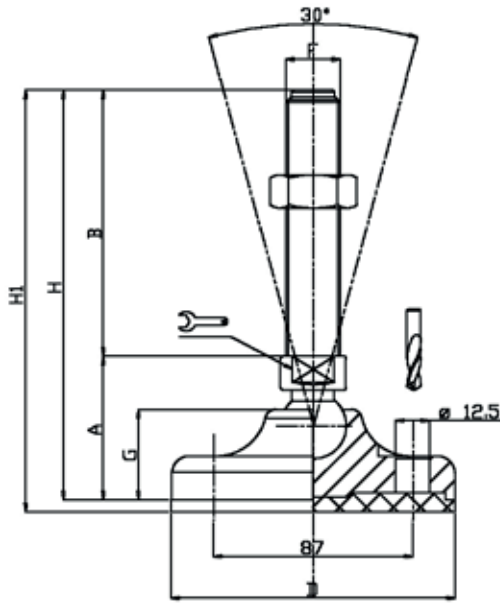

CODICE - CODE		descrizione description	DIMENSIONI PRINCIPALI - MAIN DIMENSIONS								CARICO STATICO STATIC LOAD NEWTON	
standard standard	antiscivolo antislip		A	B	D		F	G	H	H1		
10410	10411	M24X75	57	75	Ø 123	20	M24	37	132	135	35000	
10412	10413	M24X100	57	100	Ø 123	20	M24	37	157	160	35000	
10414	10415	M24X125	57	125	Ø 123	20	M24	37	182	185	35000	
*	10416	10417	M24X150	57	150	Ø 123	20	M24	37	207	210	35000
	10418	10419	M24X175	57	175	Ø 123	20	M24	37	232	235	35000
*	10420	10421	M24X200	57	200	Ø 123	20	M24	37	257	260	35000
	10422	10423	M24X225	57	225	Ø 123	20	M24	37	282	285	35000
	10424	10425	M24X250	57	250	Ø 123	20	M24	37	307	310	35000
	10426	10427	M30X100	58	100	Ø 123	26	M30	37	158	161	35000
	10428	10429	M30X125	58	125	Ø 123	26	M30	37	183	186	35000
*	10430	10431	M30X150	58	150	Ø 123	26	M30	37	208	211	35000
	10432	10433	M30X175	58	175	Ø 123	26	M30	37	233	236	35000
*	10434	10435	M30X200	58	200	Ø 123	26	M30	37	258	261	35000
	10436	10437	M30X225	58	225	Ø 123	26	M30	37	283	286	35000
	10880	10881	M30X250	58	250	Ø 123	26	M30	37	308	311	35000

* Disponibile con Filettatura a passo fine. Aggiungere "/P2" al codice
Available with Thin pitch thread. Please, add "/P2" to the code

- Materiale base: poliammide rinforzato con fibra di vetro. A richiesta disponibile con gomma antiscivolo NBR 70 shore (codice standard = senza gomma). Materiale stelo: acciaio zincato FE. Su richiesta l'elemento di livellamento viene fornito con dado in acciaio.
- I valori dei carichi sopra riportati sono calcolati in condizioni statiche alla metà della lunghezza dello stelo filettato. Qualora s'intendesse utilizzare i supporti in presenza di vibrazioni o carichi in movimento, tali valori dovranno essere adeguatamente ridotti. Per ulteriori chiarimenti consultare il nostro ufficio tecnico. Ogni nostra responsabilità decade in caso di manomissioni o modifiche dei componenti.
- Base in black polyamide material, reinforced by fiber glass. On request non-skid plate in NBR rubber 70 shore is available (Standard code = without rubber). Galvanized steel screw. The leveling element could be supplied, on request, with steel nut.
- Load values above mentioned have to be considered referring to static conditions calculated at the half of the screw length. In conditions of vibrations or in presence of dynamic loads these values should be reduced. For further information consult our technical office. We cannot accept responsibility for mounts that have been tampered or modified.

Piede in Polyamide & Acciaio Zincato

Caratteristiche: BASE Ø 123, STELO SNODATO 30°

Features: BASE Ø 123, 30° ARTICULATED STEM

PLASTICA

Martin
Levelling Components

PLASTICA

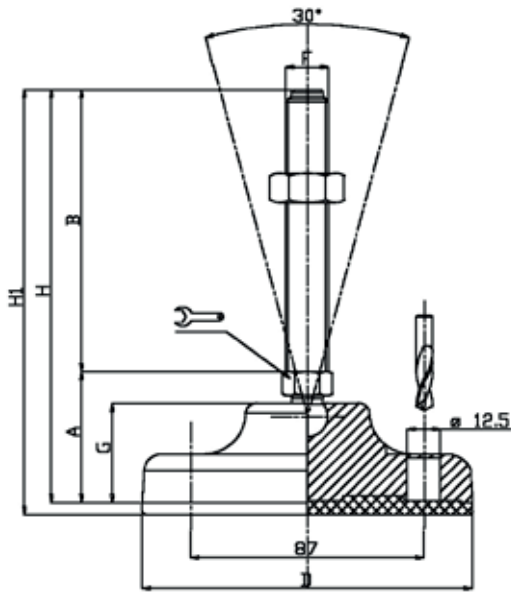

CODICE - CODE		descrizione description	DIMENSIONI PRINCIPALI - MAIN DIMENSIONS								CARICO STATICO STATIC LOAD NEWTON
standard standard	antiscivolo antislip		A	B	D		F	G	H	H1	
10374/15	10375/15	M16X50	57	50	Ø 123	16	M16	37	107	110	25000
10378/15	10379/15	M16X100	57	100	Ø 123	16	M16	37	157	160	25000
10382/15	10383/15	M16X150	57	150	Ø 123	16	M16	37	207	210	25000
10386/15	10387/15	M16X200	57	200	Ø 123	16	M16	37	257	260	25000
10394/20	10395/20	M20X100	57	100	Ø 123	17	M20	37	157	160	25000
10398/20	10399/20	M20X150	57	150	Ø 123	17	M20	37	207	210	25000
10402/20	10403/20	M20X200	57	200	Ø 123	17	M20	37	257	260	25000

- Materiale base: poliammide rinforzato con fibra di vetro. A richiesta disponibile con gomma antiscivolo NBR 70 shore (codice standard = senza gomma). Materiale stelo: acciaio zincato FE. Su richiesta l'elemento di livellamento viene fornito con dado in acciaio.
- I valori dei carichi sopra riportati sono calcolati in condizioni statiche alla metà della lunghezza dello stelo filettato. Qualora s'intendesse utilizzare i supporti in presenza di vibrazioni o carichi in movimento, tali valori dovranno essere adeguatamente ridotti. Per ulteriori chiarimenti consultare il nostro ufficio tecnico. Ogni nostra responsabilità decade in caso di manomissioni o modifiche dei componenti.
- Base in black polyamide material, reinforced by fiber glass. On request non-skid plate in NBR rubber 70 shore is available (Standard code = without rubber). Galvanized steel screw. The leveling element could be supplied, on request, with steel nut.
- Load values above mentioned have to be considered referring to static conditions calculated at the half of the screw length. In conditions of vibrations or in presence of dynamic loads these values should be reduced. For further information consult our technical office. We cannot accept responsibility for mounts that have been tampered or modified.

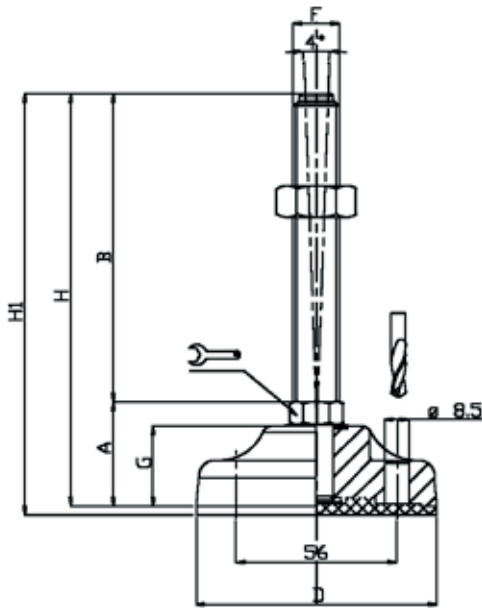

CODICE - CODE		descrizione <i>description</i>	DIMENSIONI PRINCIPALI - MAIN DIMENSIONS								CARICO STATICO STATIC LOAD NEWTON
standard <i>standard</i>	antiscivolo <i>antislip</i>		A	B	D		F	G	H	H1	
12644/10	12645/10	M10X50	36	50	Ø 83	14	M10	28	86	89	10000
12646/10	12647/10	M10X75	36	75	Ø 83	14	M10	28	111	114	10000
12648/10	12649/10	M10X100	36	100	Ø 83	14	M10	28	136	139	10000
12650/10	12651/10	M10X125	36	125	Ø 83	14	M10	28	161	164	10000
12644/12	12645/12	M12X50	36	50	Ø 83	14	M12	28	86	89	15000
12646/12	12647/12	M12X75	36	75	Ø 83	14	M12	28	111	114	15000
12648/12	12649/12	M12X100	36	100	Ø 83	14	M12	28	136	139	15000
12650/12	12651/12	M12X125	36	125	Ø 83	14	M12	28	161	164	15000
12644	12645	M14X50	36	50	Ø 83	14	M14	28	86	89	25000
12646	12647	M14X75	36	75	Ø 83	14	M14	28	111	114	25000
12648	12649	M14X100	36	100	Ø 83	14	M14	28	136	139	25000
12650	12651	M14X125	36	125	Ø 83	14	M14	28	161	164	25000
12652	12653	M14X150	36	150	Ø 83	14	M14	28	186	189	25000
12654	12655	M14X175	36	175	Ø 83	14	M14	28	211	215	25000

- Materiale base: poliammide rinforzato con fibra di vetro. A richiesta disponibile con gomma antiscivolo NBR 70 shore (codice standard = senza gomma). Materiale stelo: acciaio zincato FE. Su richiesta l'elemento di livellamento viene fornito con dado in acciaio.
- I valori dei carichi sopra riportati sono calcolati in condizioni statiche alla metà della lunghezza dello stelo filettato. Qualora s'intendesse utilizzare i supporti in presenza di vibrazioni o carichi in movimento, tali valori dovranno essere adeguatamente ridotti. Per ulteriori chiarimenti consultare il nostro ufficio tecnico. Ogni nostra responsabilità decade in caso di manomissioni o modifiche dei componenti.
- Base in black polyamide material, reinforced by fiber glass. On request non-skid plate in NBR rubber 70 shore is available (Standard code = without rubber). Galvanized steel screw. The leveling element could be supplied, on request, with steel nut.
- Load values above mentioned have to be considered referring to static conditions calculated at the half of the screw length. In conditions of vibrations or in presence of dynamic loads these values should be reduced. For further information consult our technical office. We cannot accept responsibility for mounts that have been tampered or modified.

Piede in Polyamide & Acciaio Zincato

PLASTICA

Martin
Levelling Components

PLASTICA

Caratteristiche: BASE Ø 83, STELO FISSO

Features: BASE Ø 83, FIX STEM

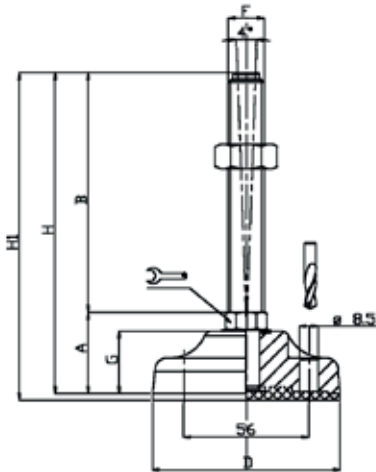

CODICE - CODE		descrizione description	DIMENSIONI PRINCIPALI - MAIN DIMENSIONS								CARICO STATICO STATIC LOAD NEWTON
standard standard	antiscivolo antislip		A	B	D	🔑	F	G	H	H1	
12672	12673	M16X50	36	50	Ø 83	16	M16	28	86	89	25000
12674	12675	M16X75	36	75	Ø 83	16	M16	28	111	114	25000
12676	12677	M16X100	36	100	Ø 83	16	M16	28	136	139	25000
12678	12679	M16X125	36	125	Ø 83	16	M16	28	161	164	25000
12680	12681	M16X150	36	150	Ø 83	16	M16	28	186	189	25000
12682	12683	M16X175	36	175	Ø 83	16	M16	28	211	214	25000
12684	12685	M16X200	36	200	Ø 83	16	M16	28	236	239	25000

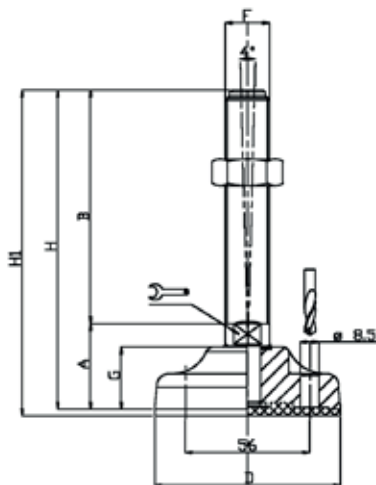

CODICE - CODE		descrizione description	DIMENSIONI PRINCIPALI - MAIN DIMENSIONS								CARICO STATICO STATIC LOAD NEWTON
standard standard	antiscivolo antislip		A	B	D	🔑	F	G	H	H1	
12704	12705	M20X75	40	75	Ø 83	17	M20	28	115	118	25000
12706	12707	M20X100	40	100	Ø 83	17	M20	28	140	143	25000
12708	12709	M20X125	40	125	Ø 83	17	M20	28	165	168	25000
12710	12711	M20X150	40	150	Ø 83	17	M20	28	190	193	25000
12712	12713	M20X175	40	175	Ø 83	17	M20	28	215	218	25000
12714	12715	M20X200	40	200	Ø 83	17	M20	28	240	243	25000
12716	12717	M20X225	40	225	Ø 83	17	M20	28	265	268	25000

• Materiale base: poliammide rinforzato con fibra di vetro. A richiesta disponibile con gomma antiscivolo NBR 70 shore (codice standard = senza gomma). Materiale stelo: acciaio zincato FE. Su richiesta l'elemento di livellamento viene fornito con dado in acciaio.

• Base in black polyamide material, reinforced by fiber glass. On request non-skid plate in NBR rubber 70 shore is available (Standard code = without rubber). Galvanized steel screw. The leveling element could be supplied, on request, with steel nut.

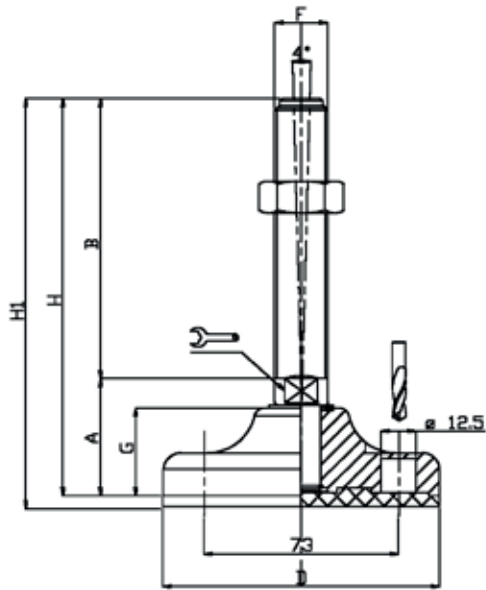

CODICE - CODE		descrizione description	DIMENSIONI PRINCIPALI - MAIN DIMENSIONS								CARICO STATICO STATIC LOAD NEWTON
standard standard	antiscivolo antislip		A	B	D		F	G	H	H1	
12734	12735	M16X50	45	50	Ø 103	17	M16	33	95	98	35000
12736	12737	M16X75	45	75	Ø 103	17	M16	33	120	123	35000
12738	12739	M16X100	45	100	Ø 103	17	M16	33	145	148	35000
12740	12741	M16X125	45	125	Ø 103	17	M16	33	170	173	35000
12742	12743	M16X150	45	150	Ø 103	17	M16	33	195	198	35000
12744	12745	M16X175	45	175	Ø 103	17	M16	33	220	223	35000
12746	12747	M16X200	45	200	Ø 103	17	M16	33	245	248	35000
12748	12749	M16X225	45	225	Ø 103	17	M16	33	270	273	35000
12768	12769	M20X75	45	75	Ø 103	17	M20	33	120	123	35000
12770	12771	M20X100	45	100	Ø 103	17	M20	33	145	148	35000
12772	12773	M20X125	45	125	Ø 103	17	M20	33	170	173	35000
12774	12775	M20X150	45	150	Ø 103	17	M20	33	195	198	35000
12776	12777	M20X175	45	175	Ø 103	17	M20	33	220	223	35000
12778	12779	M20X200	45	200	Ø 103	17	M20	33	245	248	35000
12780	12781	M20X225	45	225	Ø 103	17	M20	33	270	273	35000
12800	12801	M24X75	47	75	Ø 103	20	M24	33	122	125	35000
12802	12803	M24X100	47	100	Ø 103	20	M24	33	147	150	35000
12804	12805	M24X125	47	125	Ø 103	20	M24	33	172	175	35000
* 12806	12807	M24X150	47	150	Ø 103	20	M24	33	197	200	35000
12808	12809	M24X175	47	175	Ø 103	20	M24	33	222	225	35000
* 12810	12811	M24X200	47	200	Ø 103	20	M24	33	247	250	35000
12812	12813	M24X225	47	225	Ø 103	20	M24	33	272	275	35000

* Disponibile con Filettatura a passo fine. Aggiungere "/P2" al codice
Available with Thin pitch thread. Please, add "/P2" to the code

- Materiale base: poliammide rinforzato con fibra di vetro. A richiesta disponibile con gomma antiscivolo NBR 70 shore (codice standard = senza gomma). Materiale stelo: acciaio zincato FE. Su richiesta l'elemento di livellamento viene fornito con dado in acciaio.
- I valori dei carichi sopra riportati sono calcolati in condizioni statiche alla metà della lunghezza dello stelo filettato. Qualora s'intendesse utilizzare i supporti in presenza di vibrazioni o carichi in movimento, tali valori dovranno essere adeguatamente ridotti. Per ulteriori chiarimenti consultare il nostro ufficio tecnico. Ogni nostra responsabilità decade in caso di manomissioni o modifiche dei componenti.
- Base in black polyamide material, reinforced by fiber glass. On request non-skid plate in NBR rubber 70 shore is available (Standard code = without rubber). Galvanized steel screw. The leveling element could be supplied, on request, with steel nut.
- Load values above mentioned have to be considered referring to static conditions calculated at the half of the screw length. In conditions of vibrations or in presence of dynamic loads these values should be reduced. For further information consult our technical office. We cannot accept responsibility for mounts that have been tampered or modified.

Piede in Polyamide & Acciaio Zincato

PLASTICA

Martin
Levelling Components

PLASTICA

Caratteristiche: BASE Ø 123, STELO FISSO

Features: BASE Ø 123, FIX STEM

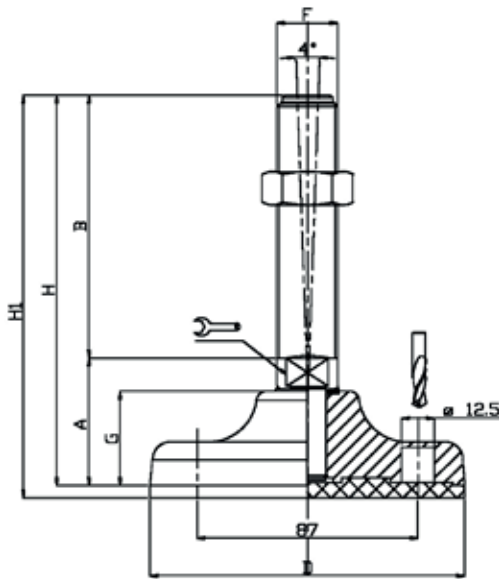

CODICE - CODE		descrizione description	DIMENSIONI PRINCIPALI - MAIN DIMENSIONS								CARICO STATICO STATIC LOAD NEWTON
standard standard	antiscivolo antislip		A	B	D		F	G	H	H1	
12830	12831	M16X50	50	50	Ø 123	20	M16	37	100	103	45000
12832	12833	M16X75	50	75	Ø 123	20	M16	37	125	128	45000
12834	12835	M16X100	50	100	Ø 123	20	M16	37	150	153	45000
12836	12837	M16X125	50	125	Ø 123	20	M16	37	175	178	45000
12838	12839	M16X150	50	150	Ø 123	20	M16	37	200	203	45000
12840	12841	M16X175	50	175	Ø 123	20	M16	37	225	228	45000
12842	12843	M16X200	50	200	Ø 123	20	M16	37	250	253	45000
12844	12845	M16X225	50	225	Ø 123	20	M16	37	275	278	45000
12864	12865	M20X75	50	75	Ø 123	20	M20	37	125	128	45000
12866	12867	M20X100	50	100	Ø 123	20	M20	37	150	153	45000
12868	12869	M20X125	50	125	Ø 123	20	M20	37	175	178	45000
12870	12871	M20X150	50	150	Ø 123	20	M20	37	200	203	45000
12872	12873	M20X175	50	175	Ø 123	20	M20	37	225	228	45000
12874	12875	M20X200	50	200	Ø 123	20	M20	37	250	253	45000
12876	12877	M20X225	50	225	Ø 123	20	M20	37	275	278	45000
12834/20	12835/20	M16X100	50	100	Ø 123	17	M16	37	150	153	40000
12838/20	12839/20	M16X150	50	150	Ø 123	17	M16	37	200	203	40000
12842/20	12843/20	M16X200	50	200	Ø 123	17	M16	37	250	253	40000
12866/20	12867/20	M20X100	50	100	Ø 123	17	M20	37	150	153	40000
12870/20	12871/20	M20X150	50	150	Ø 123	17	M20	37	200	253	40000
12874/20	12875/20	M20X200	50	200	Ø 123	17	M20	37	250	253	40000

• Materiale base: poliammide rinforzato con fibra di vetro. A richiesta disponibile con gomma antiscivolo NBR 70 shore (codice standard = senza gomma). Materiale stelo: acciaio zincato FE. Su richiesta l'elemento di livellamento viene fornito con dado in acciaio.

• I valori dei carichi sopra riportati sono calcolati in condizioni statiche alla metà della lunghezza dello stelo filettato. Qualora s'intendesse utilizzare i supporti in presenza di vibrazioni o carichi in movimento, tali valori dovranno essere adeguatamente ridotti. Per ulteriori chiarimenti consultare il nostro ufficio tecnico. Ogni nostra responsabilità decade in caso di manomissioni o modifiche dei componenti.

• Base in black polyamide material, reinforced by fiber glass. On request non-skid plate in NBR rubber 70 shore is available (Standard code = without rubber). Galvanized steel screw. The leveling element could be supplied, on request, with steel nut.

• Load values above mentioned have to be considered referring to static conditions calculated at the half of the screw length. In conditions of vibrations or in presence of dynamic loads these values should be reduced. For further information consult our technical office. We cannot accept responsibility for mounts that have been tampered or modified.

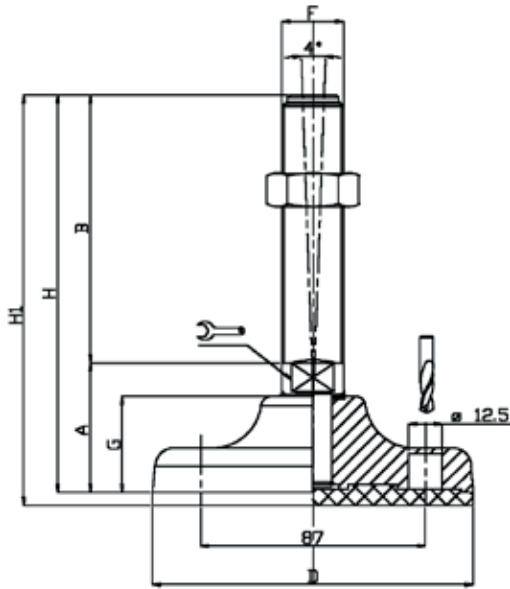

CODICE - CODE		descrizione description	DIMENSIONI PRINCIPALI - MAIN DIMENSIONS								CARICO STATICO STATIC LOAD NEWTON	
standard standard	antiscivolo antislip		A	B	D	🔧	F	G	H	H1		
12894	12895	M24X75	50	75	Ø 123	20	M24	37	125	128	45000	
12896	12897	M24X100	50	100	Ø 123	20	M24	37	150	153	45000	
12898	12899	M24X125	50	125	Ø 123	20	M24	37	175	178	45000	
*	12900	12901	M24X150	50	150	Ø 123	20	M24	37	200	203	45000
	12902	12903	M24X175	50	175	Ø 123	20	M24	37	225	228	45000
*	12904	12905	M24X200	50	200	Ø 123	20	M24	37	250	253	45000
	12906	12907	M24X225	50	225	Ø 123	20	M24	37	275	278	45000
	12908	12909	M24X250	50	250	Ø 123	20	M24	37	300	303	45000
	12924	12925	M30X100	50	100	Ø 123	26	M30	37	150	153	45000
	12926	12927	M30X125	50	125	Ø 123	26	M30	37	175	178	45000
*	12928	12929	M30X150	50	150	Ø 123	26	M30	37	200	203	45000
	12930	12931	M30X175	50	175	Ø 123	26	M30	37	225	228	45000
*	12932	12933	M30X200	50	200	Ø 123	26	M30	37	250	253	45000
	12934	12935	M30X225	50	225	Ø 123	26	M30	37	275	278	45000
	12936	12937	M30X250	50	250	Ø 123	26	M30	37	300	303	45000

* Disponibile con Filettatura a passo fine. Aggiungere "/P2" al codice
Available with Thin pitch thread. Please, add "/P2" to the code

- Materiale base: poliammide rinforzato con fibra di vetro. A richiesta disponibile con gomma antiscivolo NBR 70 shore (codice standard = senza gomma). Materiale stelo: acciaio zincato FE. Su richiesta l'elemento di livellamento viene fornito con dado in acciaio.
- I valori dei carichi sopra riportati sono calcolati in condizioni statiche alla metà della lunghezza dello stelo filettato. Qualora s'intendesse utilizzare i supporti in presenza di vibrazioni o carichi in movimento, tali valori dovranno essere adeguatamente ridotti. Per ulteriori chiarimenti consultare il nostro ufficio tecnico. Ogni nostra responsabilità decade in caso di manomissioni o modifiche dei componenti.
- Base in black polyamide material, reinforced by fiber glass. On request non-skid plate in NBR rubber 70 shore is available (Standard code = without rubber). Galvanized steel screw. The leveling element could be supplied, on request, with steel nut.
- Load values above mentioned have to be considered referring to static conditions calculated at the half of the screw length. In conditions of vibrations or in presence of dynamic loads these values should be reduced. For further information consult our technical office. We cannot accept responsibility for mounts that have been tampered or modified.