

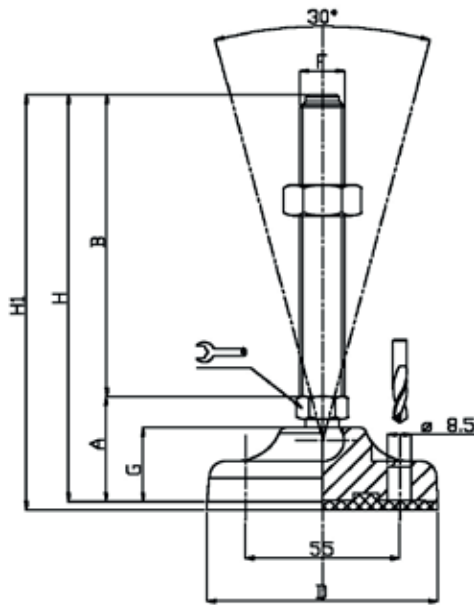

Caratteristiche: BASE Ø 83, STELO SNODATO 30°

Features: BASE Ø 83, 30° ARTICULATED STEM



CODICE - CODE		descrizione description	DIMENSIONI PRINCIPALI - MAIN DIMENSIONS								CARICO STATICO STATIC LOAD NEWTON
standard standard	antiscivolo antislip		A	B	D		F	G	H	H1	
10074/10	10075/10	M10X50	38	50	Ø 83	14	M10	27	88	91	15000
10076/10	10077/10	M10X75	38	75	Ø 83	14	M10	27	113	116	15000
10078/10	10079/10	M10X100	38	100	Ø 83	14	M10	27	138	141	15000
10080/10	10081/10	M10X125	38	125	Ø 83	14	M10	27	163	166	15000
10074/12	10075/12	M12X50	38	50	Ø 83	14	M12	27	88	91	15000
10076/12	10077/12	M12X75	38	75	Ø 83	14	M12	27	113	116	15000
10078/12	10079/12	M12X100	38	100	Ø 83	14	M12	27	138	141	15000
10080/12	10081/12	M12X125	38	125	Ø 83	14	M12	27	163	166	15000
10074/14	10075/14	M14X50	38	50	Ø 83	14	M14	27	88	91	20000
10076/14	10077/14	M14X75	38	75	Ø 83	14	M14	27	113	116	20000
10078/14	10079/14	M14X100	38	100	Ø 83	14	M14	27	138	141	20000
10080/14	10081/14	M14X125	38	125	Ø 83	14	M14	27	163	166	20000
10082/14	10083/14	M14X150	38	150	Ø 83	14	M14	27	188	191	20000
10084/14	10085/14	M14X175	38	175	Ø 83	14	M14	27	213	216	20000

• Materiale base: poliammide rinforzato con fibra di vetro. A richiesta disponibile con gomma antiscivolo NBR 70 shore (codice standard = senza gomma). Materiale stelo: acciaio inox AISI 304 (a richiesta AISI 316). Su richiesta l'elemento di livellamento viene fornito con dado in acciaio.

• I valori dei carichi sopra riportati sono calcolati in condizioni statiche alla metà della lunghezza dello stelo filettato. Qualora s'intendesse utilizzare i supporti in presenza di vibrazioni o carichi in movimento, tali valori dovranno essere adeguatamente ridotti. Per ulteriori chiarimenti consultare il nostro ufficio tecnico. Ogni nostra responsabilità decade in caso di manomissioni o modifiche dei componenti.

• Base in black polyamide material, reinforced by fiber glass. On request non-skid plate in NBR rubber 70 shore is available (Standard code = without rubber). Stainless steel screw in 1.4301 (1.4401 on specific request). The leveling mount could be supplied, on request, with steel nut.

• Load values above mentioned have to be considered referring to static conditions calculated at the half of the screw length. In conditions of vibrations or in presence of dynamic loads these values should be reduced. For further information consult our technical office. We cannot accept responsibility for mounts that have been tampered or modified.