

DETACHABLE TORQUE HINGE

HG-RNM30

HINGES



Window Width	Max. 900 mm
Window Height	Max. 450 mm
Window Thickness	28 - 35 mm
Window Weight	Max. 5.5 kg

Features

- Hinge recommended for use on the sides of windows to allow ventilation.
- Free stop: can hold position at any angle.
- Successfully passed 20,000 rotation cycles in a private test.
- Can easily be removed without the need for tools in order to perform maintenance.
- Safety arm can lock hinge shaft in place, preventing unintentional removal.

Parts Included

- Pan head tapping screw 4x20
- Countersunk head tapping screw 4x20

Remarks

Vertical use only.

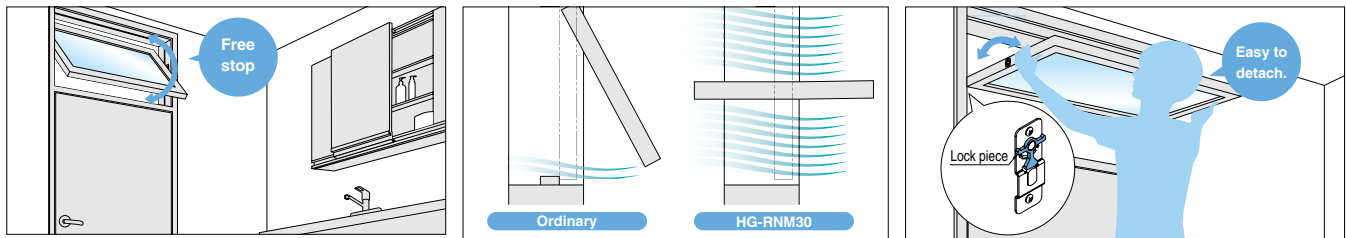

Installation

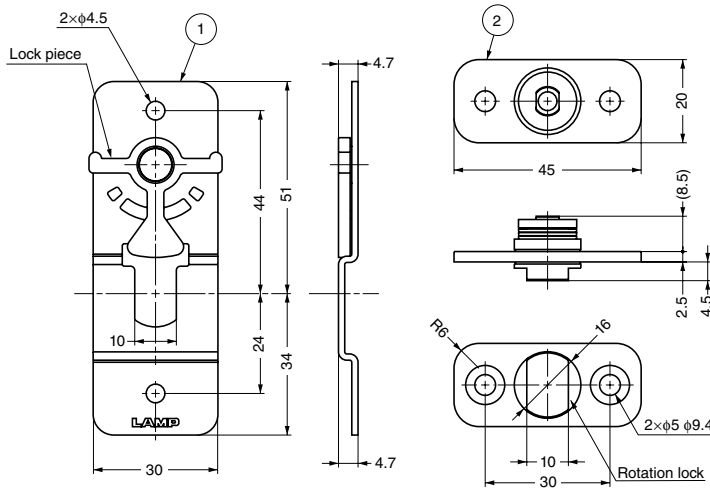
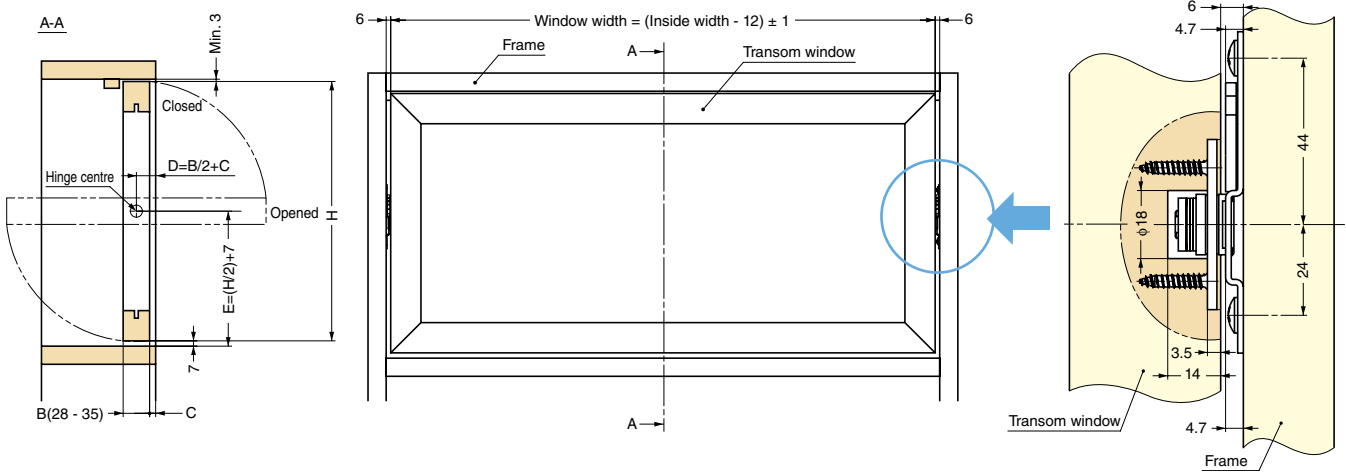

Cut Out Dimensions

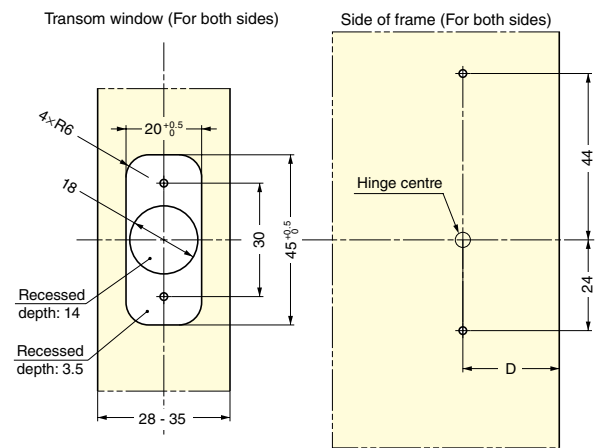

Item Code	Item Name	Torque Moment (Per pair)	Weight	Box	Carton
170-033-319	HG-RNM30-SET	3.0 ^{+20%} N·m (30.6 ^{+20%} kgf·cm)	112 g	15 sets	120 sets

No.	Part Name	Material
①	Strike	Stainless Steel, POM
②	Hinge	Stainless Steel

DETACHABLE TORQUE HINGE