

CONCEALED HINGE FOR SHEET METAL HT160V2 With Mounting Plate

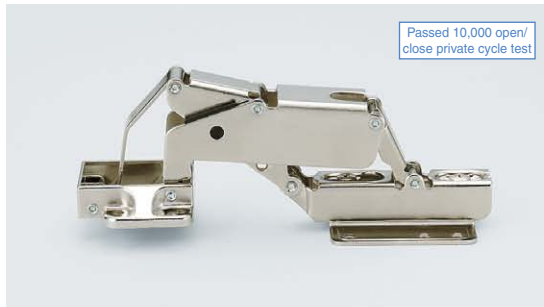

- For sheet metal doors.
- Overlay adjustment (Max. $\pm 0.3\text{mm}$) by turning the overlay adjustment screw.
- Spacer on the slide arms reduces arm wear and door sagging.
- Door opens without interfering with side cabinets or wall.
- For more details, please contact local representatives.

[Applications]

- Small vending machines, ticket vending machines, contiguous doors, door of cabinet embedded in the wall, etc.

[Parts Included]

- Mounting plate

TORQUE HINGES

DAMPER HINGES

LIFT ASSIST HINGES

DETENT HINGES

CONCEALED HINGES

BUTT HINGES

PIANO HINGES

STEP HINGES

LIFT-OFF HINGES

PIVOT HINGES

SPRING HINGES

CLEAN ROOM HINGES

HINGES FOR ALUMINIUM FRAME

DROP HINGES

GLASS DOOR HINGES

SPECIAL HINGES

● Outline drawing S=1/4

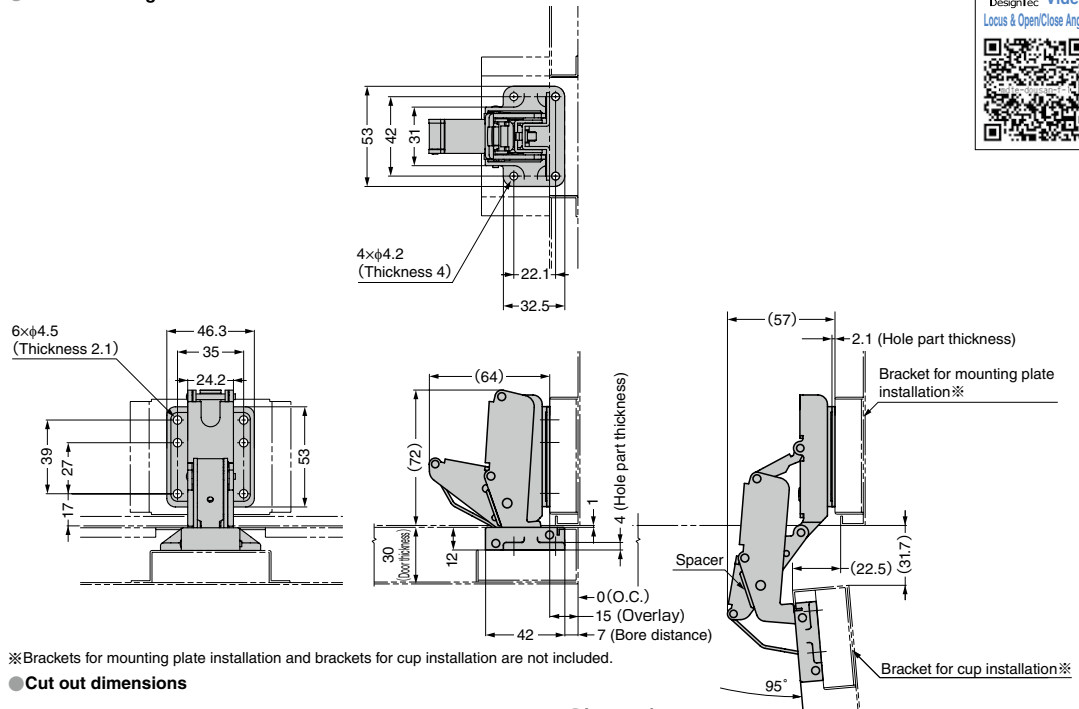

**Brackets for mounting plate installation and brackets for cup installation are not included.

● Cut out dimensions

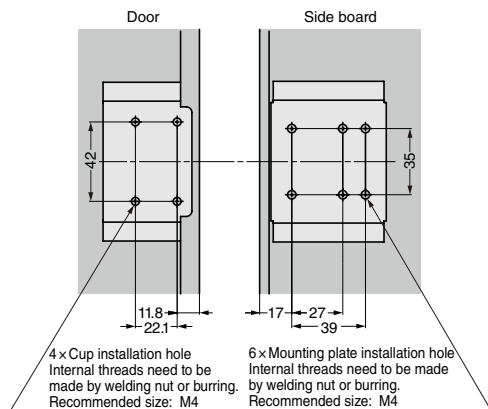

Drawing above is Bore Distance 7 mm, Door Thickness 30 mm and 15 mm Overlay.

● Locus chart

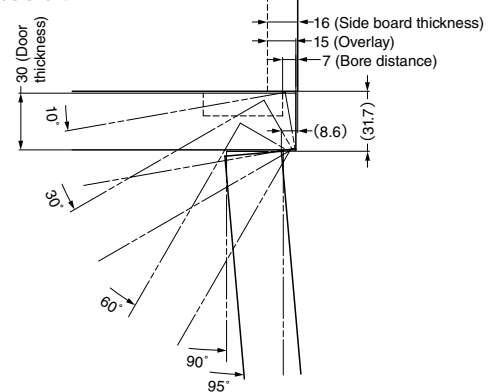

Reference door weight: 20 kg
(In case of door size W450 x H800, installation pitch 550, using 2 pcs vertically)

RoHS	CAD	Item Code	Item Name	Material	Finish / Colour	Weight (g)	Box (pcs)
CE	3D	160-070-393	HT160V2	Body/Steel, Cup/Zinc Alloy (ZDC), Spacer/POM	Body • Cup/Nickel, Spacer/Black	252.6	50