

Robot kit

ROB-SET FXCB YASKAWA

Part no.:10.01.43.00131

<https://www.schmalz.com/10.01.43.00131>

Homepage > Vacuum Technology for Automation > Vacuum Components > Area Gripping Systems and End Effectors > Vacuum Area Gripping Systems FXCB/FMCB > Robot set FXCB > ROB-SET FXCB YASKAWA

Complete vacuum system for connecting to lightweight robots



with: area gripper FXCB
for: YASKAWA
Type: HC10DT

Design Data

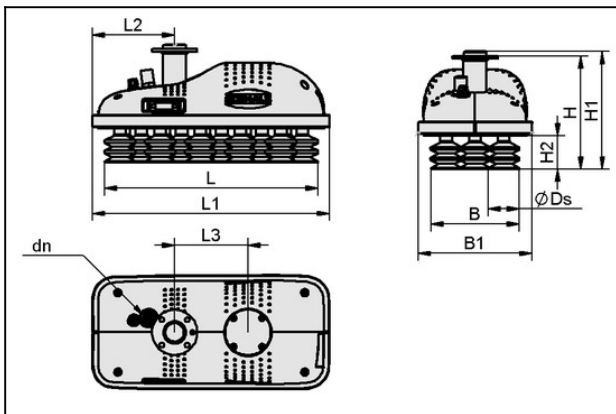

Attribute	Value
B	123.2 mm
B1	159 mm
H	158 mm
H1	164 mm
H2	47 mm
L	297 mm
L1	331 mm
L2	114.4 mm
L3	102 mm
dn	10 mm

Contact to Schmalz

J. Schmalz GmbH | Johannes-Schmalz-Straße, 72293 Glatten, Deutschland | +49 7443 2403-102 | customercenter@schmalz.de

Robot kit

ROB-SET FXCB YASKAWA

Part no.:10.01.43.00131

<https://www.schmalz.com/10.01.43.00131>

Technical Data

Attribute	Value
Weight	2.169 kg
Suction rate (max.)	525.9 l/min
Number of suction cells	15
Maximum load	8 kg

Depending on the region, the technical characteristics of the robot types may vary. The specified compatibility of the set refers to the models commonly used in Europe.

Spare Parts

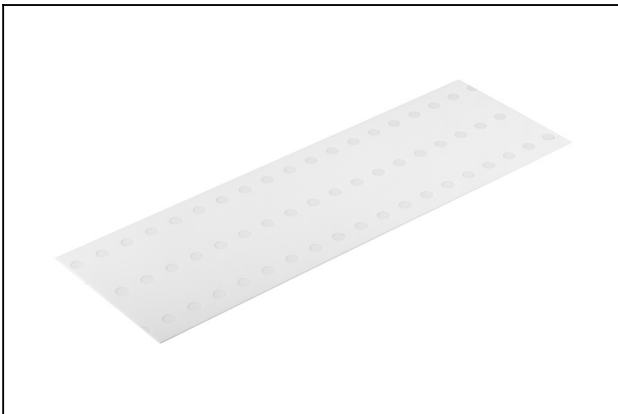

MASK-FOL SW110 294 3R18 FLGR

Part no.10.01.11.03375

Front foil

Length L: 294 mm

Width B: 109.8 mm

Arrangement: 3 rows, 18mm

Shape: flow resistors

Nozzle diameter: 1.1 mm

for: Large-area vacuum gripper

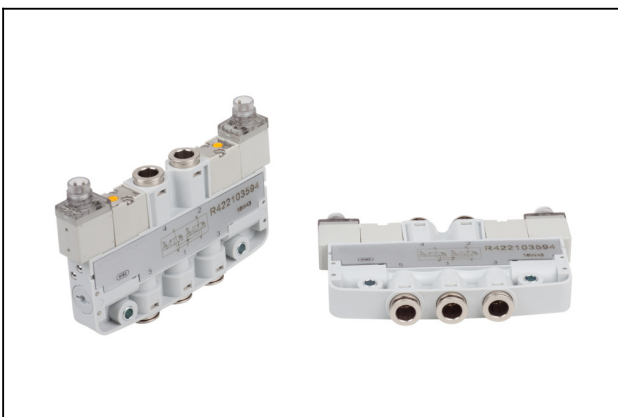

EMVP 2.35 24V-DC 2x3/2 NO/NC CAR

Part no.10.01.11.03420

Solenoid valve EMVP for vacuum, pneumatic pilot control

Nominal size: 2.35 mm

Voltage: 24V - DC

Function: 2x 3/2-way valve

Control: Optionally NO/NC

Pressure range (operating pressure):

3.00 ... 7.00 bar

Shape: Cartridge

Nominal flow rate: 15 m³/h

Weight: 0.064 kg

Contact to Schmalz

J. Schmalz GmbH | Johannes-Schmalz-Straße, 72293 Glatten, Deutschland | +49 7443 2403-102 | customercenter@schmalz.de

Robot kit

ROB-SET FXCB YASKAWA

Part no.:10.01.43.00131

<https://www.schmalz.com/10.01.43.00131>

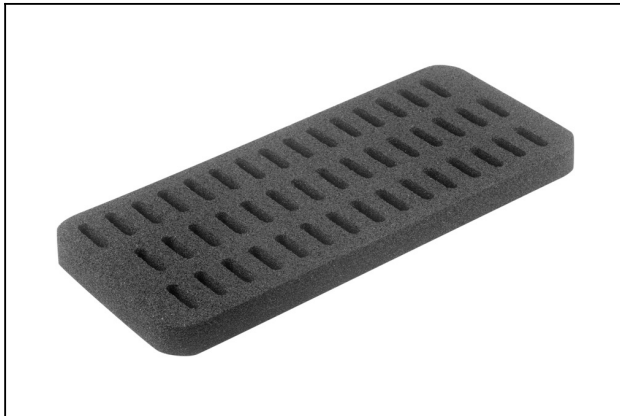

DI-PL 300x130 3R18 LL-20x7 O20 KE

Part no.10.01.11.03658

Sealing plate (FXCB/FMCB)

Length L: 300 mm

Width B: 130 mm

Arrangement: 3 rows, 18mm

Cell size: slot 20x7mm

Material-Type: Foam O, Height 20 mm

with: Adhesive tape on one side

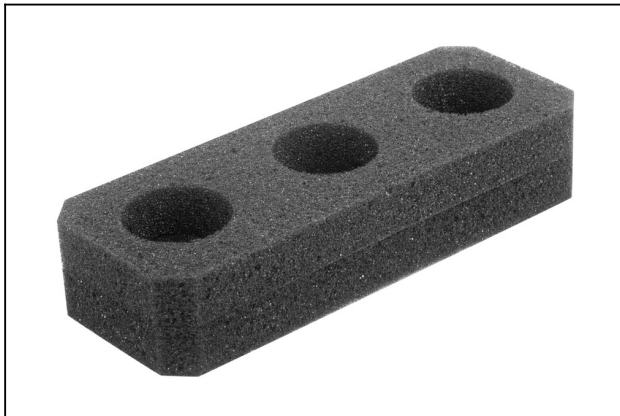

SD 97x34x20 FXCB

Part no.10.01.43.00005

Silencer for vacuum generators

Length L: 97 mm

Width B: 34 mm

Height H: 20 mm

for: area gripper FXCB

Accessories



VSL 10-7 PU

Part no.10.07.09.00084

Hose for vacuum and compressed-air systems

External diameter D: 10 mm

Internal diameter d: 7 mm

Length (max): 50 m

Material: PU

Installation radius (min): 60 mm

Colour: Transparent

Pressure range (operating pressure):

-0.95 ... 10.00 bar

Ambient temperature: -40 ... 85 °C