



Gripping System SLG

Assembly Instructions

Note

The Assembly instructions were originally written in German. Store in a safe place for future reference. Subject to technical changes without notice. No responsibility is taken for printing or other types of errors.

Published by

© J. Schmalz GmbH, 11/19

This document is protected by copyright. J. Schmalz GmbH retains the rights established thereby. Reproduction of the contents, in full or in part, is only permitted within the limits of the legal provisions of copyright law. Any modifications to or abridgments of the document are prohibited without explicit written agreement from J. Schmalz GmbH.

Contact

J. Schmalz GmbH

Johannes-Schmalz-Str. 1

72293 Glatten, Germany

T: +49 7443 2403-0

schmalz@schmalz.de

www.schmalz.com

Contact information for Schmalz companies and trade partners worldwide can be found at:

www.schmalz.com/salesnetwork

Contents

1	Important Information	5
1.1	Warranty and Liability	5
1.2	The technical documentation is part of the product	5
1.3	Note on Using this Document	5
1.4	Warnings in this document	6
1.5	Symbol	6
1.6	Type Plate	6
1.7	Other Applicable Documents	7
2	Fundamental Safety Instructions	8
2.1	Intended Use	8
2.2	Non-Intended Use	8
2.3	Danger Zone	8
2.4	Environmental and Operating Conditions	9
2.5	Personnel Qualifications	10
2.6	Personal Protective Equipment	11
2.7	Technical Condition	11
2.8	Responsibility of the Integrator	11
2.9	Country-Specific Regulations for the Operating Company	12
3	Product Description	13
3.1	General Description of the Gripper	13
3.2	SLG-EE (Optional ECBPi)	13
3.3	SLG-IP (with vacuum nozzle(s))	14
3.4	SLG-EV (with external vacuum generator)	15
3.5	NFC Interface	15
4	Technical Data	17
4.1	General Parameters	17
4.2	Dimensions	17
5	Transport and Storage	20
5.1	Checking the Delivery	20
5.2	Reusing the Packaging	20
6	Installation	21

- 6.1 Installation Instructions 21
- 6.2 Mechanical Attachment 21
- 6.3 Electrical Connection 23
- 6.4 Pneumatic connection 23

- 7 Start of Operations 26
 - 7.1 Personnel Qualification 26
 - 7.2 Before Initial Start of Operations 26

- 8 Operation 28
 - 8.1 Preparations 28

- 9 Troubleshooting 30
 - 9.1 Safety 30
 - 9.2 Faults, Causes, Solutions 30

- 10 Maintenance 32
 - 10.1 Safety 32
 - 10.2 Maintenance Schedule 32
 - 10.3 Cleaning the Gripper 33
 - 10.4 Removing the Ejector Module 34
 - 10.5 Disassembling the Vacuum Switch 34
 - 10.6 Accessories, Spare Parts and Wearing Parts 34

- 11 Disposing of the Product 35

- 12 EC Conformity 36

1 Important Information

1.1 Warranty and Liability

J. Schmalz GmbH, as a supplier and manufacturer of vacuum technology, takes no responsibility for the functioning of lightweight gripping systems SLG in a specific process.

The exact application parameters and the individual environment are important for selecting the right components.

The specifications for our products are based on our current technical knowledge and experience, as well as the available literature. We encourage you to test the products under the specific conditions that apply to your application purposes, and we would be glad to use our experience to assist you.

The packaging material, the goods that are packaged, the fill level, porosity, surface condition, center of gravity or the air content of the workpiece influence the entire handling process.

Following functional testing, different suction cup sizes, additional suction cups, a higher pumping rate or modifications to the configuration may be necessary.

Therefore, J. Schmalz GmbH accepts no liability and excludes all legal claims for damages.

The products and the configurator are subject to technical changes or further development without notice.

We are not liable for any damage resulting from the use of non-original spare parts or accessories.

The exclusive use of original spare parts is a prerequisite for the proper functioning of the gripper and for the validity of the warranty.

Wearing parts are not covered by the warranty.

1.2 The technical documentation is part of the product

1. For problem-free and safe operation, follow the instructions in the documents.
2. Keep the technical documentation in close proximity to the product. The documentation must be accessible to personnel at all times.
3. Pass on the technical documentation to subsequent users.
 - ⇒ Failure to follow the instructions in these Assembly instructions may result in life-threatening injuries!
 - ⇒ Schmalz is not liable for damage or malfunctions that result from failure to heed these instructions.

If you still have questions after reading the technical documentation, contact Schmalz service at:

www.schmalz.com/services

1.3 Note on Using this Document

J. Schmalz GmbH is generally referred to as Schmalz in these Assembly instructions.

These Assembly instructions contain important notes and information about the different operating phases of the product:

- Transport, storage, start of operations and decommissioning
- Safe operation, required maintenance, rectification of any faults

The Assembly instructions describe the product at the time of delivery by Schmalz.

1.4 Warnings in this document

Warnings warn against hazards that may occur when handling the product. There are four levels of danger that you can recognize by the signal word.

Signal word	Meaning
DANGER	Indicates a high-risk hazard which, if not avoided, will result in death or serious injury.
WARNING	Indicates a medium-risk hazard which, if not avoided, could result in death or serious injury.
CAUTION	Indicates a low-risk hazard which, if not avoided, could result in minor or moderate injury.
NOTE	Indicates a danger that leads to property damage.

1.5 Symbol



This symbol indicates useful and important information.

- ✓ This symbol represents a prerequisite that must be met prior to an operational step.
- ▶ This symbol represents an action to be performed.
- ⇒ This symbol represents the result of an action.

Actions that consist of more than one step are numbered:

1. First action to be performed.
2. Second action to be performed.

1.6 Type Plate

The type plate is permanently attached to the product and must always be clearly legible.

The type plate contains the following data:

- Order number
- Product key
- Device weight

- ▶ Please specify all the information above when ordering replacement parts, making warranty claims or for any other inquiries.

1.7 Other Applicable Documents

The following operating instructions must also be observed when setting up the gripper SLG:

- The operating instructions for the CobotPump
- The operating instructions for the ejector nozzle SEP
- The operating instructions for the vacuum switch VSi

2 Fundamental Safety Instructions

2.1 Intended Use

The order confirmation describes specifically how the system is to be used. All other types of use are considered non-intended use.

The system must only be operated at the supply voltage specified for the components.

The properties of the load are defined in the order confirmation.

The load must only be vacuum-gripped in the position defined in advance or on initial set-up of the product.

Ensure that the load cannot slide or tip over during all phases of operation.

Use only the connections, mounting holes and attachment materials that have been provided.

The gripping system is built in accordance with the latest standards of technology and is delivered in a safe operating condition; however, hazards may arise during use.

The maximum lift capacity must not be exceeded (> See ch. Technical Data).

2.2 Non-Intended Use

Schmalz accepts no liability for damage caused by the use of the gripper for purposes other than those described under Intended Use. Use of the gripper for loads that are not specified in the order confirmation or that have different physical properties than those specified in the order confirmation shall be considered non-intended use. In particular, the following are considered non-intended use:

- Use as a climbing aid
- Lifting people or animals
- Storing loads while picked up
- Supporting the lifting force by applying external forces
- Applying suction to building components, equipment or supporting surfaces.
- Applying suction to bulk materials (e.g. granulates)
- Evacuation of objects that are in danger of imploding
- Freeing building components or immovable equipment

2.3 Danger Zone

Persons in the danger zone of the gripper may suffer life-threatening injuries.

Operating modes of the gripper SLG

- Automatic operation on the industrial robot or gantry
- Collaborative operation on the lightweight robot (cobot)

For both operating modes, the system integrator must carry out a risk assessment of the entire system and define the danger zone precisely. In doing so, country-specific regulations and obligations must be observed.

Automatic operation on the industrial robot or gantry

- During automatic operation of the handling system, no persons or animals may be present in the danger zone.
- In other operating modes, ensure that no unauthorized persons or animals are present in the danger zone.
- Ensure that collisions with the surrounding environment and objects do not occur to prevent the load from breaking off.

During automatic operation of the handling system, the danger zone must be secured to prevent access by persons (protective barrier or sensor system).

The danger zone of the gripper includes the following areas:

- The area directly below the gripper and load.
- The area immediately surrounding the gripper and load.
- The working area of the automatic handling system.

2.4 Environmental and Operating Conditions

The gripping system must **not** be operated under the following conditions:

- In potentially explosive atmospheres
- In environments with acidic or alkaline media



CAUTION

Dangerous gases, vapors or dusts are sucked in and dispersed by the vacuum generator.

Difficulty breathing.

- ▶ Before commencing work, ensure that the ambient air does not contain any hazardous substances.
- ▶ Make sure that there are no hazardous substances on the load that can be sucked in.
- ▶ If the ambient air is dusty, use a dust filter (particle size max. 5 µm).



⚠ CAUTION

Blockage of the vacuum system from sucking in liquids

Risk of injury from falling load!

- ▶ Do not pick up liquids or bulk materials.
 - ▶ Observe the gauge and the signal from the warning device.
 - ▶ Observe the vacuum display and the signal from the warning device.
 - ▶ If the suction of liquids cannot be avoided, use a water separator (contact Schmalz service).
-

The gripping system must be operated only under the following conditions:

- The environment must be free from humidity, moisture, dirt, dust, oil or other climatic conditions that may reduce friction levels.
- The gripping system must be sufficiently dimensioned for the loads to be lifted.
 - ▶ If in doubt, consult Schmalz before the start of operations.

2.5 Personnel Qualifications

Unqualified personnel cannot recognize dangers and are therefore exposed to higher risks!

The operating company must ensure the following points:

- The personnel must be commissioned for the activities described in these instructions.
- The staff must be at least 18 years of age and physically and mentally capable.
- The product must be operated only by persons who have undergone appropriate training.
- Personnel must receive regular safety briefings (frequency as per country-specific regulations).
- Work on electrical equipment must be carried out only by qualified electrical specialists.
- Installation, maintenance, and repairs must be carried out only by specialists from J. Schmalz GmbH or by persons who can prove that they have undergone appropriate training at Schmalz.

The following target groups are addressed in these instructions:

- Mechanical and electrical specialists who are responsible for installing, troubleshooting and maintaining the product.

The operator of the system must comply with country-specific regulations regarding the age, ability and training of the personnel.

Valid for Germany:

A qualified employee is defined as an employee who has received technical training and has the knowledge and experience – including knowledge of applicable regulations – necessary to enable him or her to recognize possible dangers and implement the appropriate safety measures while performing tasks. Qualified personnel must observe the pertinent industry-specific rules and regulations.

2.6 Personal Protective Equipment

To avoid injury, always use appropriate protective equipment that is suitable for the situation. The protective equipment must meet the following standards:

- Protective work shoes in safety class S1 or higher
- Sturdy work gloves in safety category 2133 or higher
- Industrial helmet
- Ear protection class L or higher
- Eye protection class F
- Hair net
- Closely fitting clothing

2.7 Technical Condition

If the product is operated while in a defective state, safety and function will be impaired.

- Only operate the gripper when in perfect working order as originally delivered.
- Follow the maintenance schedule.
- Use only original spare parts from Schmalz.
- If the operating behavior changes, check the gripper for faults. Rectify faults immediately!
- Do not independently modify or alter the gripper.
- Safety features must not be disabled under any circumstances.

Schmalz assumes no liability for consequences of modifications over which it has no control.

2.8 Responsibility of the Integrator

The integrator is obligated to perform a risk assessment for the environmental conditions at the installation location.

The integrator is also responsible for third parties in the working area of the gripper. The operating company must ensure that they have the appropriate qualifications and skills.

- Ensure that regular breaks are taken.
- Ensure that the gripper cannot be started up by unauthorized persons.
- During maintenance or repair work, ensure that the gripper cannot be operated.
- Clearly define the responsibilities for the various activities performed with the gripper.
- Ensure that these responsibilities are observed.
- When handling unfamiliar loads, carry out tests where necessary to ensure safe operation:
 - The load is sufficiently rigid that it cannot be damaged during handling.

2.9 Country-Specific Regulations for the Operating Company

1. Observe the country-specific regulations regarding accident prevention, safety testing and environmental protection.
2. The gripper is to be used in combination with an automated handling system (gantry/robot). Ensure that the appropriate country-specific regulations and safety regulations are adhered to.

3 Product Description

3.1 General Description of the Gripper

The gripping systems use a vacuum to lift defined products. One or more workpieces of different sizes can be lifted. The gripping system achieves its maximum load-bearing capacity when all of the suction cups are placed on an airtight workpiece with a smooth surface.

The handling system is responsible for the motion in the various axes (robot/gantry).

The gripper SLG is produced using an additive manufacturing process. It is composed of the gripper head and the gripper body. The gripper head is preselected by the customer in a configuration module. The connection flange selected by the customer is integrated in the gripper head (selected flange is listed in the order confirmation). Based on the customer information, the gripper body is then individually calculated using the stored algorithm.

Three different versions can be selected for the gripper head:

- Connection to a CobotPump (ECBPI)
- Connection directly to a collaborative robot or a handling system. Depending on the customer's design, one or two vacuum nozzles are integrated in the gripper head.
- Connection directly to a collaborative robot or a handling system. The gripper head has a direct connection for an external vacuum generator.

The geometry of the gripper body is dependent on:

- The size of the workpiece to be transported
- The variable number of suction points (max. 12)
- The selected suction cups
- The position and orientation of the suction cups (the customer selects the gripping position on the workpiece, the stored algorithm lines up the suction cups perpendicular to the workpiece surface)

Each gripper is individual thanks to its customized design. Therefore, the gripper body and the suction cups are not generally displayed in the following chapters.

3.2 SLG-EE (Optional ECBPI)

The gripper is mounted on the ECBPI; the connection to the robot is established via its mechanical interface.

The vacuum is supplied to the gripper via the interface between the ECBPI and gripper. The ECBPI is responsible for vacuum monitoring.

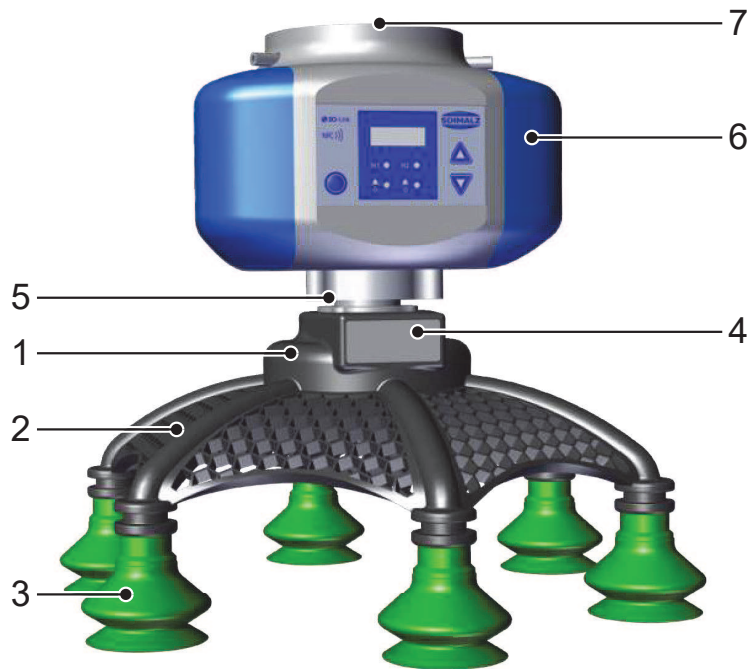

1	Gripper head	2	Gripper body (geometry depending on configuration)
3	Suction cup (number depending on configuration)	4	Type plate
5	Interface to ECBPi	6	ECBPi (optional)
7	Interface to robot		

3.3 SLG-IP (with vacuum nozzle(s))

The gripper is mounted directly on the robot. The vacuum nozzles are supplied via the compressed air connection. The vacuum is monitored via the vacuum switch.

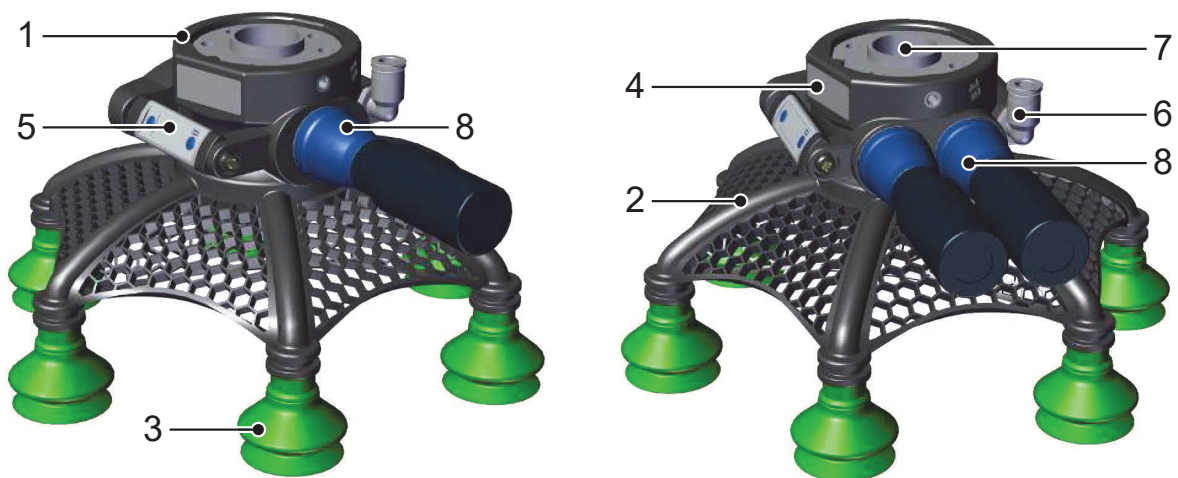

1	Gripper head	2	Gripper body (geometry depending on configuration)
3	Suction cup (number depending on configuration)	4	Type plate
5	Vacuum switch	6	Compressed air connector, hose diameter 8
7	Interface to robot	8	Vacuum nozzle(s)

3.4 SLG-EV (with external vacuum generator)

The gripper is mounted directly on the robot. The vacuum nozzles are supplied via the compressed air connection. The vacuum is monitored via the vacuum switch.

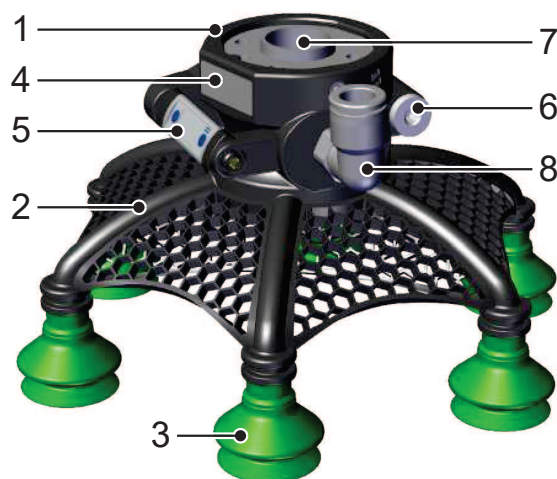

1	Gripper head	2	Gripper body (geometry depending on configuration)
3	Suction cup (number depending on configuration)	4	Type plate
5	Vacuum switch	6	Compressed air connection (optional)
7	Interface to robot	8	Vacuum connection

3.5 NFC Interface

NFC (Near Field Communication) refers to a standard for wireless data transfer between different devices over a short distance.

The CobotPump and the vacuum switch VSi function as passive NFC tags that can be read or written by a reading device such as a smartphone or tablet with NFC activated. Access to the CobotPump / vacuum switch parameters via NFC also works when the supply voltage is not connected.

There are two options for communicating via NFC:

- Read access only can be obtained via a website viewed in a browser. For this, no additional app is needed. It requires only that NFC and the Internet connection are enabled.
- Another option for communication is the "Schmalz ControlRoom" control and service app. This permits not only read access but also active reconfiguration of the CobotPump's parameters via NFC. The Schmalz ControlRoom app is available at the Google Play Store.



The reading distance is very short for NFC applications. Determine the position of the NFC antenna in the reading device used. If parameters of the device are modified via NFC, then the power supply must subsequently remain stable for at least three seconds to prevent data loss (error E01).

Further information on NFC functionality can be found in the operating instructions for the CobotPump and vacuum switch (> See ch. Other Applicable Documents).

4 Technical Data

4.1 General Parameters

Parameter	Gripper type			Unit
	SLG-EV	SLG-IP	SLG-EE	
Number of suction points	See order confirmation (min. 1 / max. 12)			
Operating pressure	—	2.0 – 6.0	—	bar
Maximum degree of evacuation	90	61	75	%
Optimal input pressure	—	4.0	—	bar
Compressed air consumption	—	74 (1xSEP) 148 (2xSEP)	—	l/min
Suction flow	—	175 (1xSEP) 350 (2xSEP)	12	l/min
Required suction flow rate	See configuration summary	—	—	
Permissible lift capacity	10	10	2.5 – 10 (depending on the load case)	kg
Operating voltage	24	24	24	V DC
Permitted temperature range	0 to +60	0 to +60	+5 to +45	° C
Sound level at full coverage	—	69	57	dBA
Protection class	IP40	IP40	IP40	
Weight	See order confirmation			

Compressed air provided by the customer: Dry, filtered air in acc. with ISO 8573-1:2010 [7:4:4]

4.2 Dimensions

In all gripper versions, the center of the flange can vary in terms of installation space.

SLG-EE

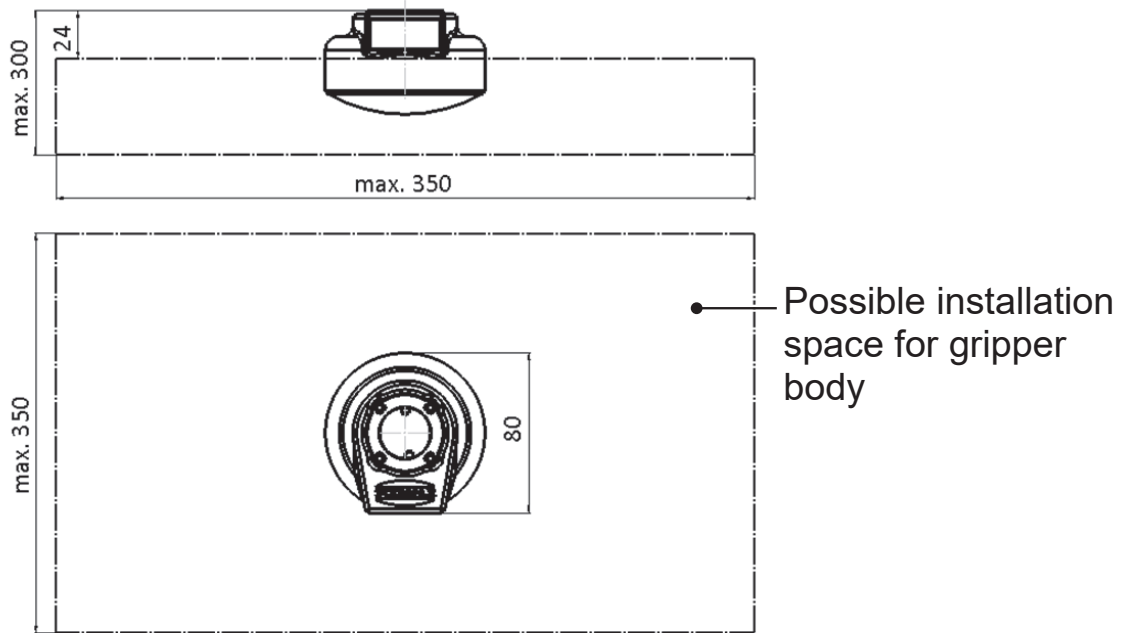

SLG-EV

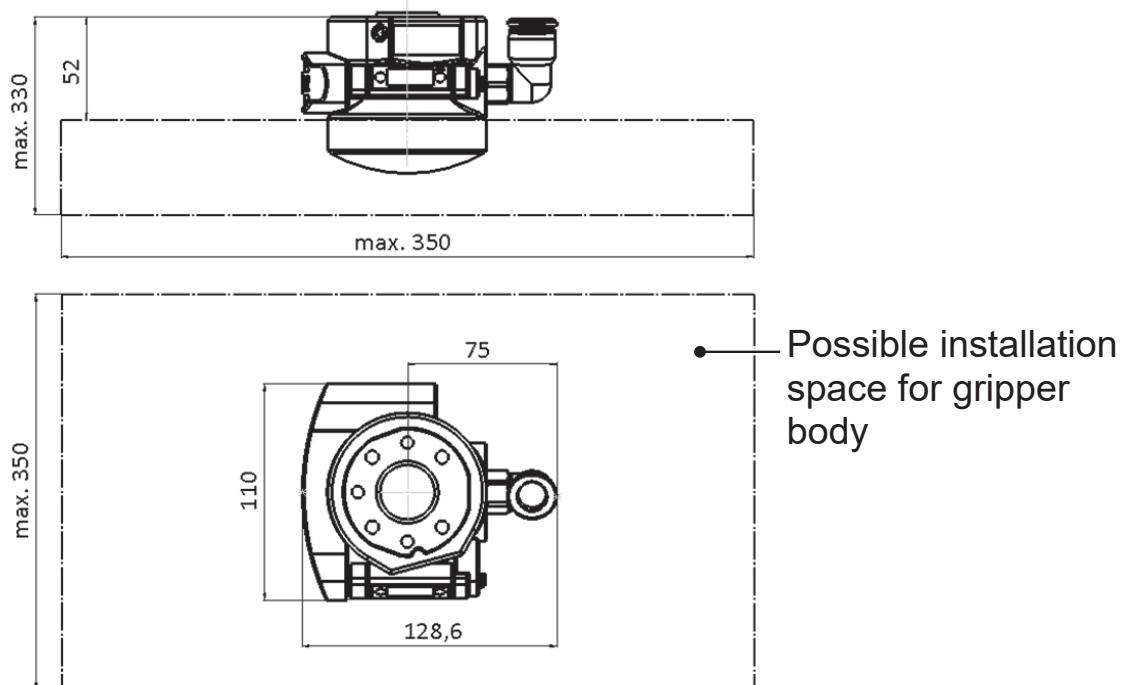

SLG-1xSEP

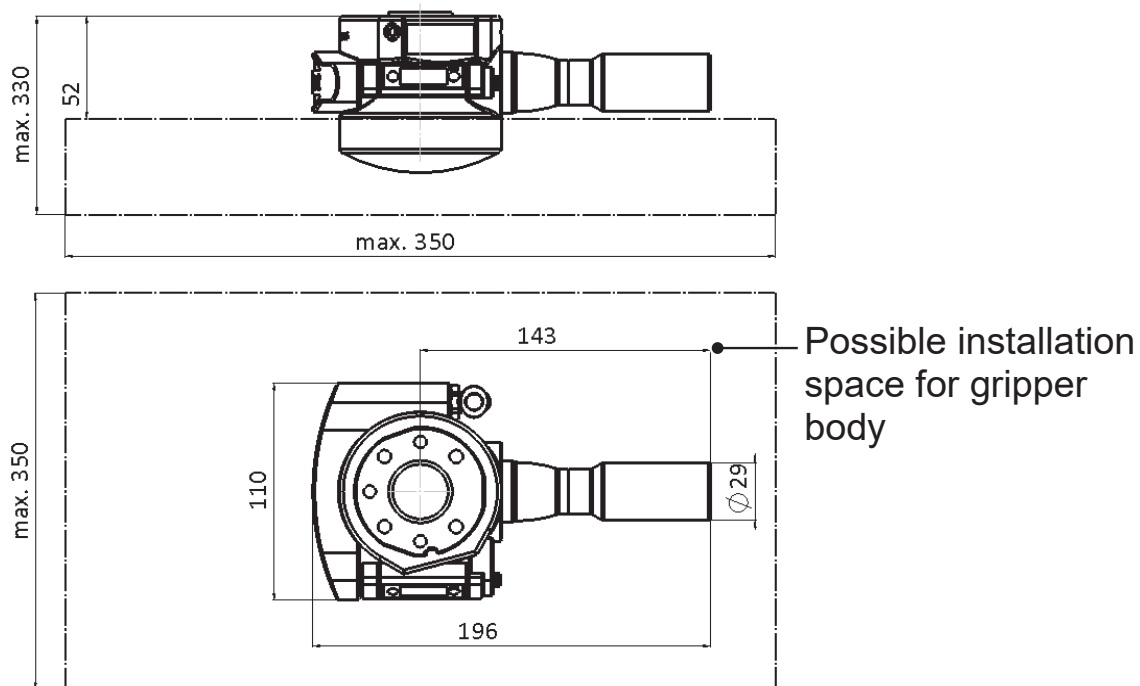

SLG-2xSEP

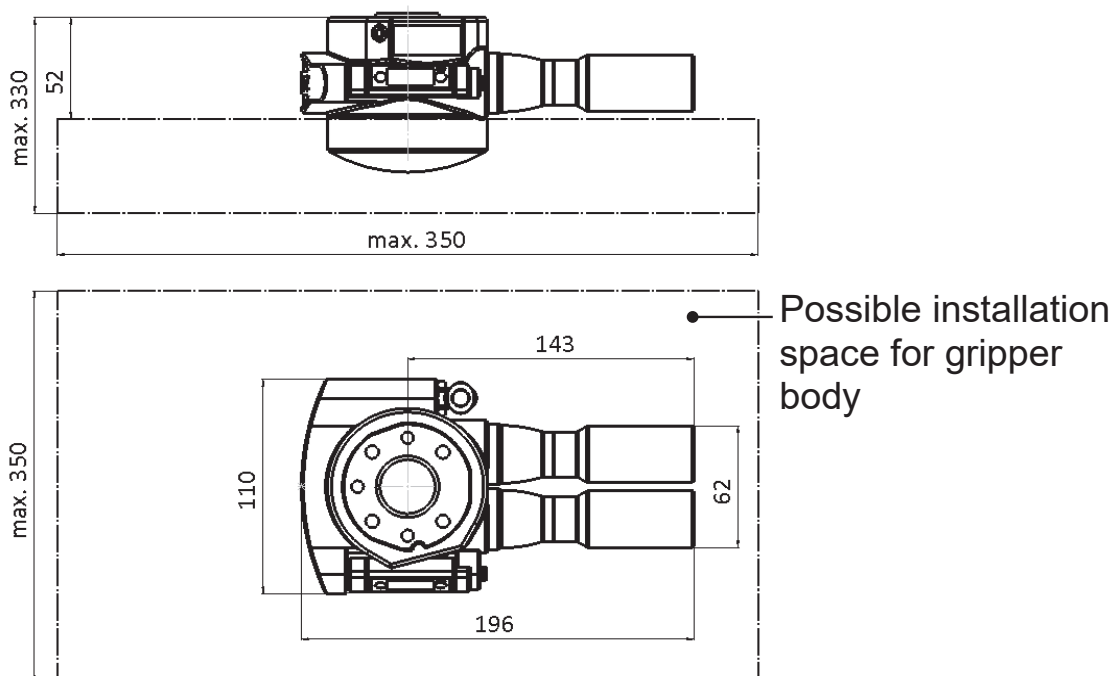

5 Transport and Storage

5.1 Checking the Delivery

The scope of delivery can be found in the order confirmation. The weights and dimensions are listed in the delivery notes.

1. Compare the entire delivery with the supplied delivery notes to make sure nothing is missing.
2. Damage caused by defective packaging or occurring in transit must be reported immediately to the carrier and J. Schmalz GmbH.

5.2 Reusing the Packaging

The product is delivered in cardboard packaging. The packaging should be reused to safely transport the product at a later stage.



Keep the packaging for future transport or storage.

6 Installation

6.1 Installation Instructions



⚠ CAUTION

Improper installation or maintenance

Personal injury or damage to property

- ▶ Prior to installation and before maintenance work, the product must be disconnected from the power supply, depressurized (vented to atmospheric pressure) and secured against unauthorized restart!

The gripper SLG may be installed in any position.

The gripper SLG can be attached to a robot or a CobotPump using a replaceable flange adapter plate. The correct flange adapter plate is already specified by the customer when selecting the robot type.

If the gripper is attached to the robot via the CobotPump, the CobotPump operating instructions must also be observed (> See ch. Other Applicable Documents).

6.2 Mechanical Attachment

Mounting the SLG-IP / SLG-EV (directly on the robot)

- ▶ Mount the flange plate on the robot,
Tightening torque as specified by the robot manufacturer

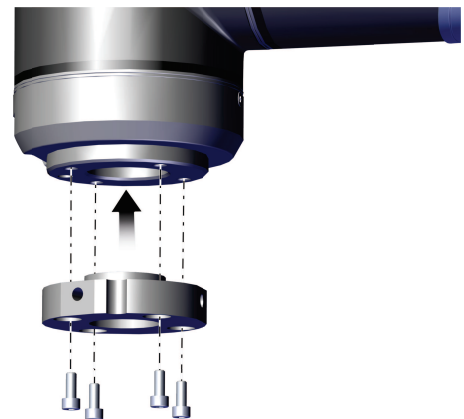

1. Attach gripper to flange plate

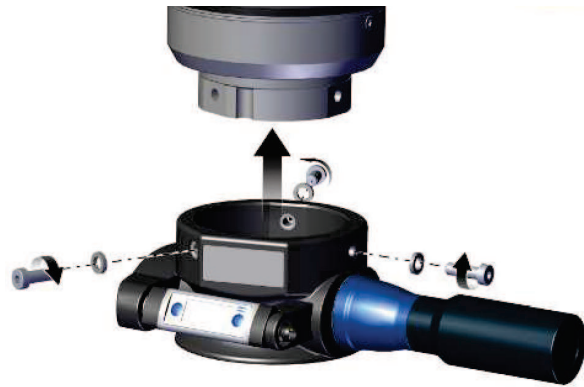

2. Mount the gripper on the flange plate using Nord-Lock washers and machine screws, tightening torque 2 Nm

Mounting the SLG-EE (via CobotPump)

- ▶ Screw flange module to CobotPump, tightening torque 1.3 Nm



- ▶ Attach CobotPump to gripper SLG



- ▶ Turn CobotPump against gripper SLG, engage bayonet



- ▶ Tighten bayonet with lock nut

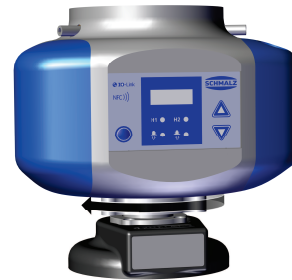

6.3 Electrical Connection



DANGER

Electric shock from touching live components

Serious injury or death!

- ▶ Make sure that the electrical components are not live before installation, maintenance and troubleshooting.
- ▶ Switch off the mains switch and secure against unauthorized restart.

The gripper type SLG-EE has no electrical connections. In this case, the operating instructions for the CobotPump must be observed (> See ch. Other Applicable Documents).

For gripper types SLG-EV and SLG-IP, a vacuum switch is mounted. The connection is established using a 5-pin M8 plug integrated in the vacuum switch. Observe the operating instructions for the vacuum switch (> See ch. Other Applicable Documents).

6.4 Pneumatic connection

1. Shorten the hoses and pipelines as much as possible.
2. Keep hose lines free of bends and crimps.
3. Lay hose lines in such a way that they do not rub.



CAUTION

Compressed air or vacuum in direct contact with the eye

Severe eye injury

- ▶ Wear eye protection
- ▶ Do not look into compressed air openings
- ▶ Do not look into the silencer air stream
- ▶ Do not look into vacuum openings, e.g. suction cups

SLG-EE

The gripper type SLG-EE has no pneumatic connections. The vacuum is generated in the CobotPump and passed through the bayonet connection to the gripper.

SLG-IP

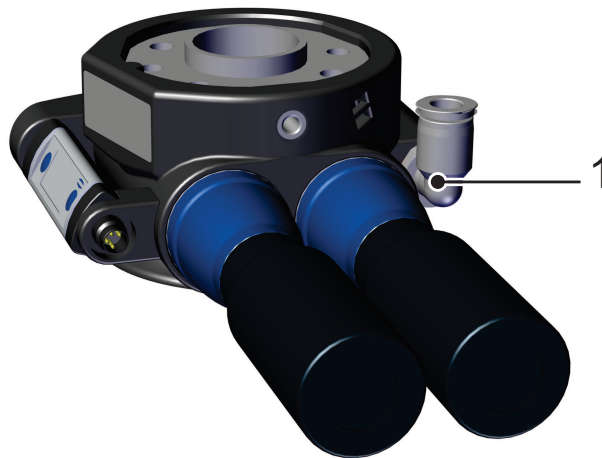

1 Compressed air connector, hose diameter 8

SLG-EV



1 Compressed air connection 1/4" thread

2 Vacuum connection,
hose diameter 14

The gripper is supplied by an external vacuum.

In order to ensure that the workpiece is deposited quickly, a blow-off pulse can be produced via the compressed air connection. The factory-fitted plug must be replaced by a plug-in screw union for this purpose.

7 Start of Operations

7.1 Personnel Qualification

Unqualified personnel cannot recognize dangers and are therefore exposed to higher risks!

1. Only instruct qualified personnel to perform the tasks described in these operating instructions.
2. The product may only be operated by persons who have undergone appropriate training.
3. Electrical work and installations may only be carried out by qualified electrical specialists.
4. Assembly and maintenance work must only be carried out by qualified personnel.

7.2 Before Initial Start of Operations

Before the initial start of operations following the installation, repair, servicing or maintenance work, you must check the following:

- All mechanical connectors are properly attached and secured.
- All screws and nuts are tightened to specified torques.
- All components are installed.
- The safety distances have been maintained.
- The electrical cable and supply hoses are properly routed.
- The EMERGENCY STOP switch for the overall system is working.
- The type plate and the carrying capacity plate are easily legible.



DANGER

Electric shock from touching live components

Serious injury or death!

- ▶ Make sure that the electrical components are not live before installation, maintenance and troubleshooting.
- ▶ Switch off the mains switch and secure against unauthorized restart.



CAUTION

Noise pollution due to incorrect installation of the pressure and vacuum connections

Hearing damage

- ▶ Correct installation.
- ▶ Wear ear protectors.

**⚠ CAUTION**

Vacuum close to the eye

Severe eye injury!

- ▶ Wear eye protection.
- ▶ Do not look into vacuum openings, e.g. suction cups.

**⚠ CAUTION**

Risk of crushing if the suction cup is abruptly attached to a workpiece

- ▶ Do not place any body parts between the suction cup and the workpiece

Handling process

1. Placement of the gripper on the workpiece
 - Position the gripper optimally on the workpiece
 - Suction cups must be compressed by at least 50%
2. Generate or establish vacuum
 - SLG-EE: Switch on ECBPi
 - SLG-IP: Apply compressed air to the compressed air connection
 - SLG-EV: Attach vacuum to the vacuum connection
3. Movement of the gripper after reaching the pre-set vacuum value
4. Lower workpieces onto clear, even surfaces
5. Only switch off the vacuum when the workpiece rests completely and safely on a secure surface
 - When switching off the device, the suction cups are automatically ventilated
 - SLG-EV: Optionally, a blow-off pulse can be produced at the compressed air connection.
6. Return gripper to a neutral state, switch off SUCTION and BLOW-OFF

8 Operation

8.1 Preparations

- ▶ The product must be operated only by persons who have undergone appropriate training.

To avoid injury, always use appropriate protective equipment that is suitable for the situation. The protective equipment must meet the following standards:

- Protective work shoes in safety class S1 or higher
- Ear protection class L or higher
- Sturdy work gloves in safety category 2133 or higher
- Eye protection class F



WARNING

Extraction of hazardous media, liquids or bulk material

Personal injury or damage to property!

- ▶ Do not extract harmful media such as dust, oil mists, vapors, aerosols etc.
 - ▶ Do not extract aggressive gases or media such as acids, acid fumes, bases, biocides, disinfectants or detergents.
 - ▶ Do not extract liquids or bulk materials, e.g. granulates.
-

Before each activation of the gripping system, the following measures must be taken:

1. Check the device for visible damage. Correct any faults or report them to the supervising personnel.
2. Ensure that only authorized persons are present in the working area of the machine or system in order to prevent any hazard from switching on the machine.
3. Ensure that the danger zone of the machine or system is free of persons during automatic operation in non-HRC applications.

**⚠ WARNING**

Applications with collaborative robots:

Insufficient vacuum generation or insufficient coverage of the gripper.

The load drops immediately.

Risk of injury from falling load!

- ▶ The operator must be separated from the handling area of the load by a secure barrier.

9 Troubleshooting

9.1 Safety

Maintenance work may only be carried out by qualified personnel.



⚠ WARNING

Risk of injury due to incorrect maintenance or troubleshooting

- ▶ Check the proper functioning of the product, especially the safety features, after every maintenance or troubleshooting operation.



⚠ CAUTION

Improper installation or maintenance

Personal injury or damage to property

- ▶ Prior to installation and before maintenance work, the product must be disconnected from the power supply, depressurized (vented to atmospheric pressure) and secured against unauthorized restart!

9.2 Faults, Causes, Solutions

Fault	Possible cause	Solution
Vacuum level is not reached or vacuum is created too slowly	Leakage in hose line	Check hose connections
	Leakage or wear on the suction cup/sealing	Check the suction cup/sealing and replace if necessary
	Dirty ejectors/CobotPump	Remove and clean SEP nozzles See other applicable documents for Cobot-Pump
Load cannot be held	Vacuum level too low	See above for possible causes
	Suction force not suitable for load	Increase vacuum or connect additional grippers if necessary
	The gripper is not pressed firmly enough onto the workpiece to be lifted	Press the gripper more firmly onto the workpiece. On even surfaces, we recommend compressing the suction cup by at least 50%.
	Too short retention time for the gripper on the workpiece to be lifted	Extend the retention time

Fault	Possible cause	Solution
	Too fast or jerky lifting of workpieces	Optimize the motion Avoid acceleration peaks (especially when lifting the workpieces)
	The workpieces to be lifted are not suitable for the grippers	Use a different gripping system
Suction cups wear out very quickly	The suction cup is angled or makes a grinding noise when applied to the workpiece to be lifted	Set it down vertically on the workpiece
Version for ext. vacuum generator only: External vacuum generator works, but workpieces are not picked up	If present: The dust filter of the vacuum generator is dirty	Clean or replace dust filter
	Suction cup is damaged/torn	Replace suction cup
	Workpiece is too heavy	Workpiece is not suitable
	Vacuum is too high	Determine the maximum possible vacuum of the vacuum generator; check the system for leaks (hose connections, sealing, etc.); valves are dirty; the workpiece is too porous
	Suction cup is not applied firmly enough	Press the suction spider more firmly onto the surface On even surfaces, we recommend compressing the suction cup by approx. 50%
Versions with internal vacuum generator only: Internal vacuum generator works, but workpieces are not picked up	Suction cup is damaged/torn	Replace suction cup
	Workpiece is too heavy	Workpiece is not suitable
	Input pressure too low (SEP version only)	Increase the input pressure. Check the hoses for leakage The workpiece is too porous
	Dirty ejectors/CobotPump	Remove and clean ejectors/CobotPump
	Suction cup is not applied firmly enough	Press the gripper more firmly onto the workpiece. On even surfaces, we recommend compressing the suction cup by at least 50%.
CobotPump not working	Electrical control is not working	Check the connections and replace CobotPump if necessary
	Faulty CobotPump	Replace or repair CobotPump (> See ch. Other Applicable Documents)

10 Maintenance

10.1 Safety

Maintenance work may only be carried out by qualified personnel.



WARNING

Risk of injury due to incorrect maintenance or troubleshooting

- ▶ Check the proper functioning of the product, especially the safety features, after every maintenance or troubleshooting operation.
-



CAUTION

Improper installation or maintenance

Personal injury or damage to property

- ▶ Prior to installation and before maintenance work, the product must be disconnected from the power supply, depressurized (vented to atmospheric pressure) and secured against unauthorized restart!
-

10.2 Maintenance Schedule



Schmalz stipulates the following checks and check intervals. The operator must comply with the legal regulations and safety regulations applicable at the location of use. These intervals apply to single-shift operation. For heavier use, such as multi-shift operation, the intervals must be shortened accordingly.

Maintenance task	Daily	Weekly	Monthly	Every six months	Yearly
Check if the vacuum generator generates unusual noise under full load?		X			
Check connections on flange for secure fit – Machine screws with Nord-Lock washers for attachment of the flange to the suction spider		X			
Check the suction cups for wear, tears and leaks. Replace if necessary.		X			
Check the ejectors/CobotPump for dirt and clean if necessary.			X		
Check the condition of the vacuum hoses (not brittle, no kinks, no chafe marks.			X		
Check all load-bearing parts (e.g. suspension) for deformation, wear or other damage.			X		
Leak test			X		
Is the electrical installation still OK? Is the cable screw union secure?				X	
Check that all the connections are secure, e.g. the screws, hose clamps, etc.				X	
Check that the type plate and lift capacity plate are legible and clean if necessary.					X
The operating instructions are available, legible, and can be accessed by personnel.					X
Check the general condition of the device.					X

10.3 Cleaning the Gripper

1. For cleaning, do not use aggressive cleaning agents such as industrial alcohol, white spirit or thinners. Only use cleaning agents with pH 7–12.
2. Remove dirt on the exterior of the device with a soft cloth and soap suds at a maximum temperature of 60° C. Make sure that the silencer is not soaked in soapy water.
3. Ensure that no moisture can reach the electrical connection or other electrical components.

10.4 Removing the Ejector Module

The ejector module (1) is fixed in the main body by the screwed-in holder cap (2).



1. Loosen holder cap (2) and pull out ejector module (1).
(The silencer (3) remains on the holder cap.)
2. For further cleaning of the ejector module, refer to operating instructions 30.30.01.00600 (> See ch. Other Applicable Documents).

10.5 Disassembling the Vacuum Switch

The vacuum switch is screwed into the main body. The screwed-down connection cable and an additional holder fix the vacuum switch in place.

- ▶ Unscrew the connection cable.
- ▶ Pull the holder (1) off the main body (dovetail guide)



- ▶ Unscrew the vacuum switch (2)



10.6 Accessories, Spare Parts and Wearing Parts

Accessories as well as spare and wearing parts can be requested from Schmalz Service with the order number and the product key.

11 Disposing of the Product

Recover the disassembled parts for recycling or reuse (provided no agreement on return or disposal has been made).

1. Dispose of the product properly after replacement or decommissioning.
2. Observe the country-specific guidelines and legal obligations for waste prevention and disposal.

12 EC Conformity

EC Declaration of Incorporation

The manufacturer Schmalz confirms that the gripping system described in these assembly instructions fulfills the following applicable EC directives:

2006/42/EC	Machinery Directive
------------	---------------------

The product specified is solely intended for installation indoors in a complete system. Startup is prohibited until the end product has been declared to comply with the Directive 2006/42/EC.

The manufacturer commits to provide special documentation of the partly completed machinery to national authorities in electronic form if requested. The special technical documentation belong to the machine as per Annex VII Part B has been created.

The following harmonized standards were applied:

EN ISO 12100	Safety of Machinery – Basic concepts, general principles for design – risk assessment
EN ISO 10218-2	Industrial Robots – Safety Requirements – Part 2: Robot Systems and Integration
EN ISO 13857	Safety of Machinery – Safety distances to prevent hazard zones being reached by upper and lower limbs

At your side worldwide

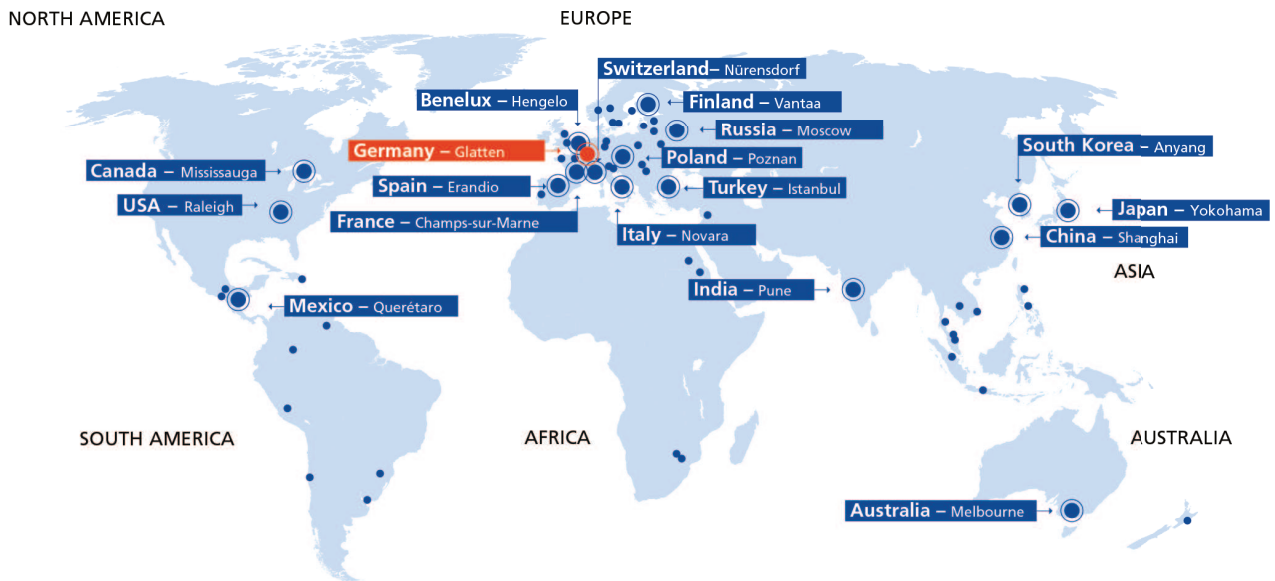

Headquarters

Schmalz Germany – Glatten

Sales Partners

You can find the Schmalz sales partner in your country at:
WWW.SCHMALZ.COM/SALESNETWORK

Subsidiaries

Schmalz Australia – Melbourne
 Schmalz Benelux – Hengelo (NL)
 Schmalz Canada – Mississauga
 Schmalz China – Shanghai
 Schmalz Finland – Vantaa
 Schmalz France – Champs-sur-Marne
 Schmalz India – Pune
 Schmalz Italy – Novara
 Schmalz Japan – Yokohama

Schmalz Mexico – Querétaro
 Schmalz Poland – Suchy Las (Poznan)
 Schmalz Russia – Moscow
 Schmalz South Korea – Anyang
 Schmalz Spain – Erandio (Vizcaya)
 Schmalz Switzerland – Nürens Dorf
 Schmalz Turkey – Istanbul
 Schmalz USA – Raleigh (NC)

Vacuum Automation

WWW.SCHMALZ.COM/AUTOMATION

Handling Systems

WWW.SCHMALZ.COM/HANDLINGSYSTEMS

J. Schmalz GmbH
 Johannes-Schmalz-Str. 1
 72293 Glatten, Germany
 T: +49 7443 2403-0
 schmalz@schmalz.de
 WWW.SCHMALZ.COM