

REVISION HISTORY			
REV	DATE	BY	DESCRIPTION
I	17SEP2019	CSN/SKB	PRN: P2019-2340

NOTES

- OPERATION: 195° TURN OF DRIVER CAUSES CAM TO ROTATE AND PULL UP AS SHOWN.
- DETERMINE TOTAL GRIP BY ADDING: MAX. OUTER DOOR THICKNESS (INCLUDE ALL ACCESSORIES) PLUS COMPRESSED FRAME GASKET AND FRAME THICKNESS.
- INSTALLATION:
 - INSERT LATCH INTO HOLE IN DOOR. CHECK FOR PROPER ORIENTATION AND OPERATION USING CAM.
 - INSTALL USING LOCKWASHER AND MOUNTING NUT M22 (27mm ACROSS FLATS). TIGHTENING TORQUE IS 20 Nm.
 - INSTALL JAM NUT, LOCKWASHER, CAM, LOCKWASHER AND JAM NUT ON SHAFT. ADJUST JAM NUTS TO POSITION CAM AT CORRECT GRIP (WITH LATCH CLOSED). TIGHTEN JAM NUTS (20 Nm MAX TORQUE) USING TWO 17mm WRENCHES.
- CAUTION: ADJUST CAM SO NO MORE THAN 7.9Nm TORQUE IS REQUIRED TO CLOSE LATCH.
- CHOOSE GRIP ACCORDING TO GRIP TABLE. CAM CAN TO BE ORDERED SEPARATELY. SEE CAM PART NUMBER IN GRIP TABLE.
- OPTIONAL: ROUND HOLE INSTALLATION WITH SPUR WASHER, PART NUMBER 90-6-875
- RECOMMENDED TO BE USED WITH SOUTHCO KEY E3-17-1

CAM PART NUMBER (ORDER CAM SEPARATELY)			
MINIMUM GRIP	MAXIMUM GRIP	CAM TYPE	CAM PART NUMBER
NO CAM			
16.4	32.2	DEEP OFFSET CAM, FORWARD	E3-28-201-24
71.3	81.2	DEEP OFFSET CAM, REVERSED	
30.4	46.1	OFFSET CAM, FORWARD	E3-28-202-24
57.6	73.3	OFFSET CAM, REVERSED	
43.9	59.6	STRAIGHT CAM	E3-28-203-24

18 MAX. OUTER DOOR THICKNESS,
(PANEL PLUS FLANGE GASKET).

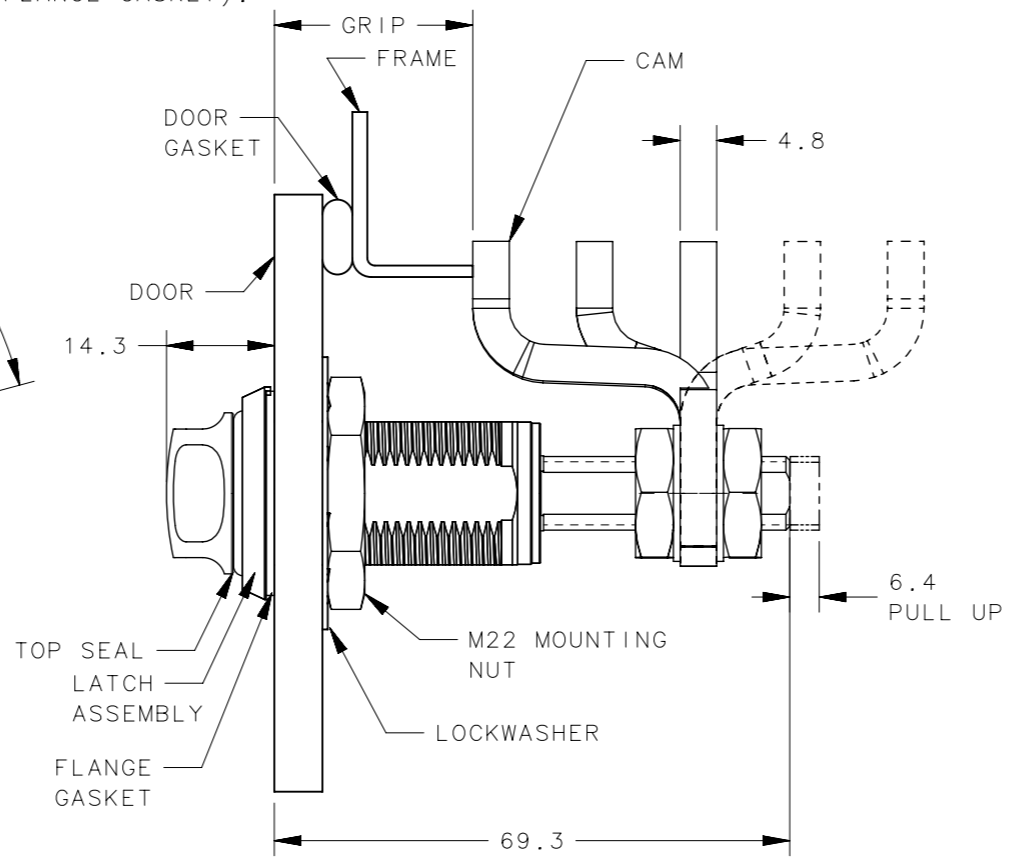
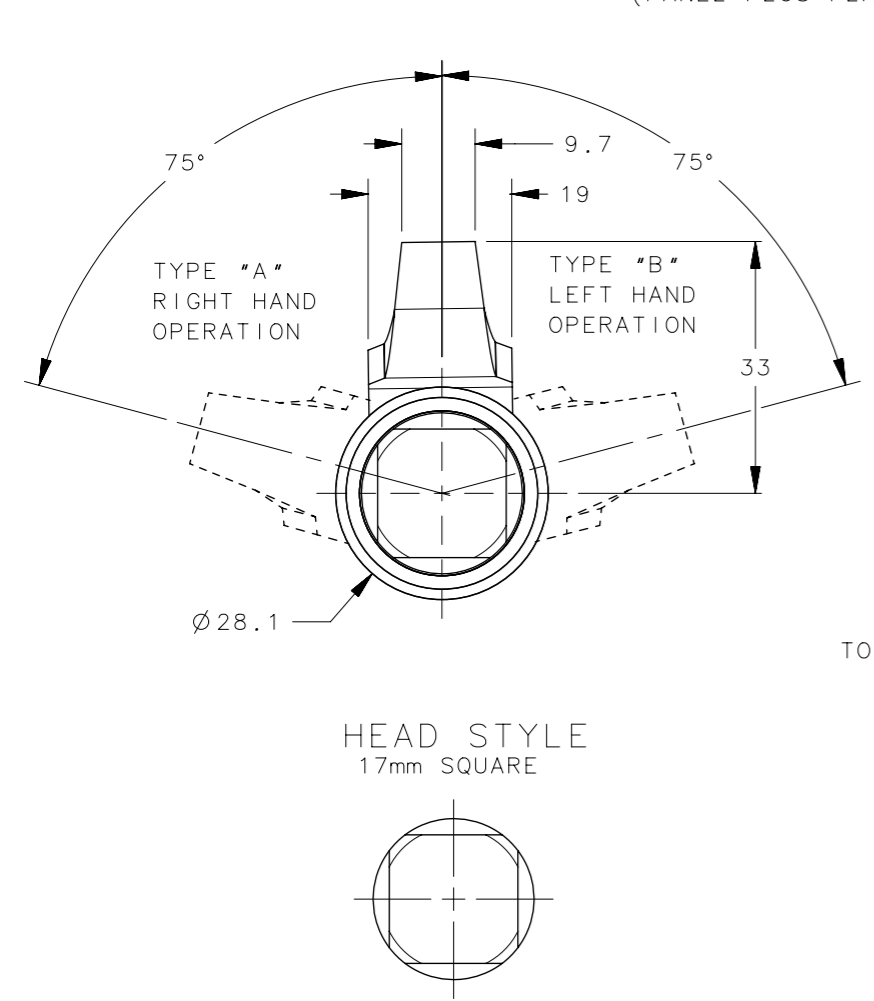

STANDARD PART NUMBER
E3-HR38-00

ROTATION
HEAD STYLE

- R = ROTATION
- 1 = LATCH SHIPPED UNASSEMBLED, TYPE A
(TURN CAP CLOCKWISE TO LATCH)
- 22 = LATCH SHIPPED UNASSEMBLED, TYPE B
(TURN CAP COUNTER-CLOCKWISE TO LATCH)

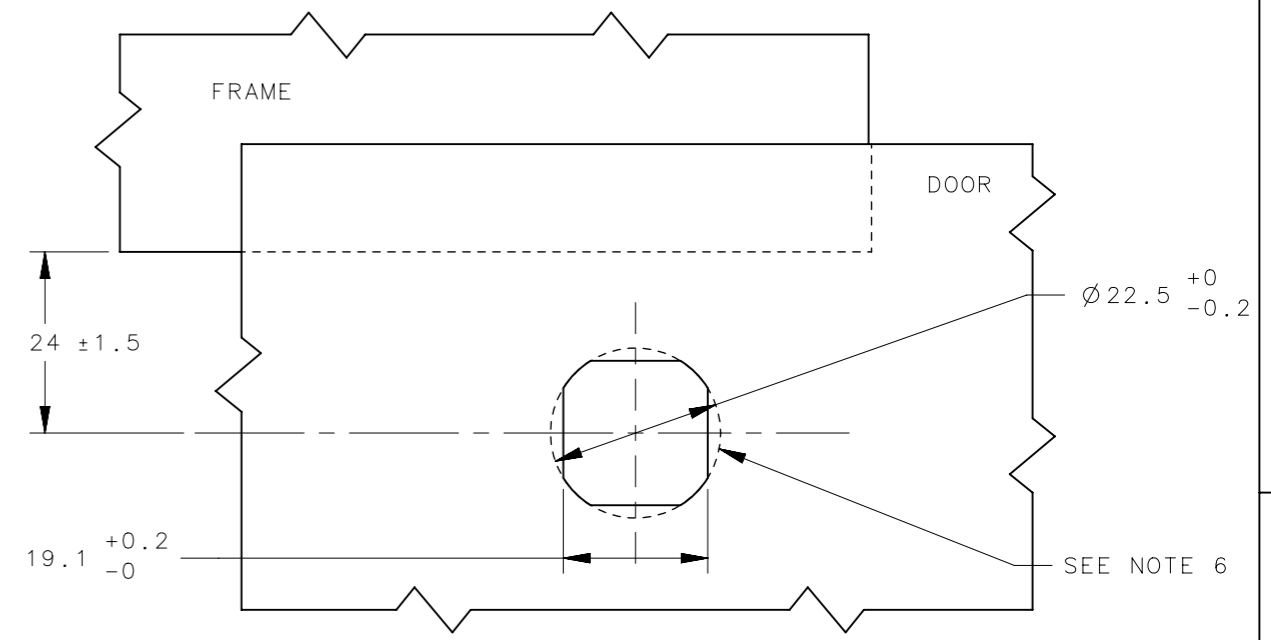

COMPONENT	MATERIAL	FINISH
M10 LOCKWASHER	STAINLESS STEEL	PASSIVATED
HOUSING	STAINLESS STEEL	ELECTROPOLISHED
CAP	STAINLESS STEEL	ELECTROPOLISHED
TOP SEAL	EPDM	BLUE
RETAINER	STAINLESS STEEL	NATURAL
SPRING	STAINLESS STEEL	NATURAL
O-RING	BUNA-N	NA
SLEEVE	STAINLESS STEEL	PASSIVATED
CAM	ALLOY STEEL	ZINC IMMERSION COATING
SHAFT	STAINLESS STEEL	PASSIVATED
PIN	STEEL	ZINC PLATE
CAM	STAINLESS STEEL	PASSIVATED
M10 NUT	STAINLESS STEEL	PASSIVATED
LOCKWASHER	STAINLESS STEEL	PASSIVATED
MOUNTING NUT	POWDERED METAL (STAINLESS STEEL)	NATURAL
GASKET SEAL	EPDM	BLUE
SEAL	EPDM	BLUE

THIRD ANGLE PROJECTION	southco [®] CONNECT • CREATE • INNOVATE		
	DESCRIPTION E3 STAINLESS STEEL HYGIENE SERIES ADJUSTABLE GRIP		
MILLIMETERS [IN]	SIZE A3	SYSTEM NX	DWG NO. J-E3-12-17
TOLERANCES UNLESS OTHERWISE NOTED	ALL DIMENSIONS WITHOUT TOLERANCES ARE FOR REFERENCE ONLY.	PER ASME Y14.5M-1994	DATE 20DEC2017
PROPRIETARY ITEM <small>EXCEPT FOR USES EXPRESSLY GRANTED IN WRITING, INFORMATION DISCLOSED HEREON IS CONFIDENTIAL AND ALL RIGHTS, PATENT AND OTHERWISE, ARE RESERVED BY SOUTHCO, INC.</small>	DRAWN BY YBS	SCALE 1:1	SHEET 1 OF 1