

ADJUSTABLE ONE WAY TORQUE HINGE

HG-TQJ100

HINGES

ADJUSTABLE ONE WAY TORQUE HINGE



Features

- Hinge with torque in only one direction. There is almost no torque in the other direction. This allows for smooth operation.
- Adjustable torque: from 0 to 10 N-m.
- Both opening direction torque type and closing direction torque type available.
- Section to adjust torque is normally covered with a cap for a sleek appearance.

Remarks

- Recommended for use in pairs.
- Use hex key (size 5) for adjustment.
- If the torque resistance decreases, please tighten the torque adjustment nut.
- Be sure to fix the slit on the opposite shaft when turning the torque adjustment nut.

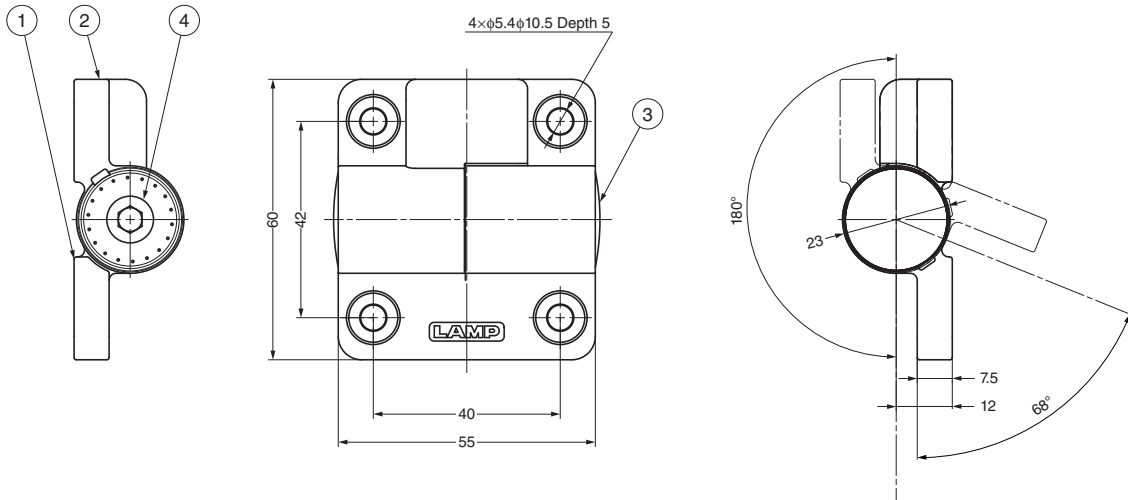

Application Example

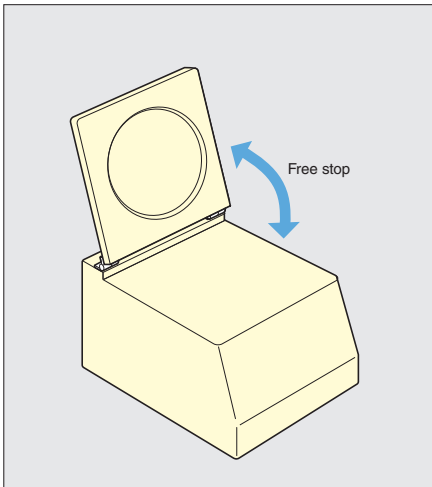

Torque Working Direction

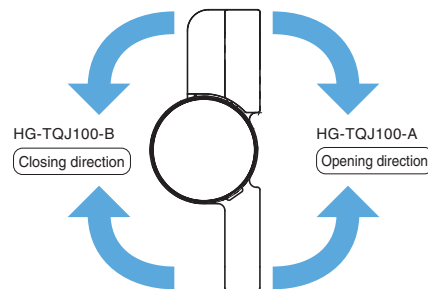

Item Code	Item Name	Torque Working Direction	Torque Moment	Weight	Box	Carton
170-032-969	HG-TQJ100-A	Opening	0 - 10 N-m (0 - 102 kgf-cm)	242 g	12 pcs	96 pcs
170-032-970	HG-TQJ100-B	Closing				

No.	Part Name	Material	Finish/Colour
①	Bracket A	Zinc Alloy	Satin Chrome
②	Bracket B		
③	Cover	Polypropylene (PP)	Dark Grey
④	Torque Adjustment Nut	Stainless Steel	-