

CLEAN ROOM HINGE HG-CV



Passed 40,000 open/close private cycle test



Oval hole type



Round hole type

- Plastic caps at rotating part prevent metal-to-metal friction and metal powder scattering.
- When opening and closing door, plastic caps will not interfere with frame .
- Aluminium alloy material, light weight and excellent design.
- Round hole type, precision type and oval hole type available. For precision type, clearance between hinge leaves and plastic caps/shaft is small.

[Applications]

- Semiconductor manufacturing equipment, clean room, aluminium frame, household equipment, etc.

[Remarks]

- Load capacity is the value when using two hinges. For calculation conditions, please refer to INDEX 1.

TORQUE HINGES

DAMPER HINGES

LIFT ASSIST HINGES

DETENT HINGES

CONCEALED HINGES

BUTT HINGES

PIANO HINGES

STEP HINGES

LIFT-OFF HINGES

PIVOT HINGES

SPRING HINGES

CLEAN ROOM HINGES

HINGES FOR ALUMINIUM FRAME

DROP HINGES

GLASS DOOR HINGES

SPECIAL HINGES

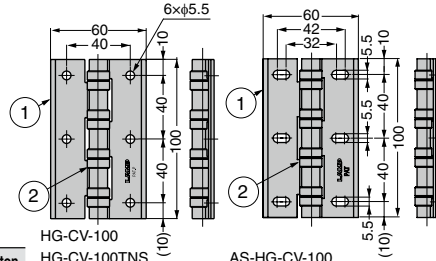
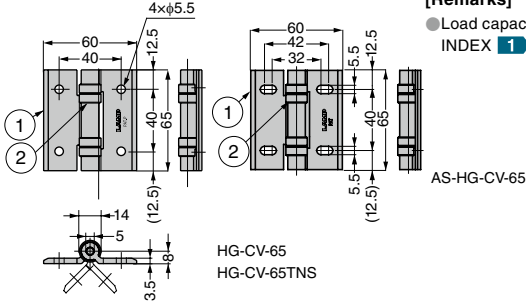

R#HS	CAD	Item Code	Item Name	Type	Load Capacity N/2 pcs	Load Capacity kgf/2 pcs	Weight (g)	Box (pcs)	Carton (pcs)
6	3D	170-091-441	HG-CV-65	Round	147	15	50	20	240
6	3D	170-091-442	HG-CV-100	Hole Type	226	23	78	20	160
6	3D	170-099-151	HG-CV-65TNS	Precision	147	15	50	20	240
6	3D	170-099-152	HG-CV-100TNS	Type	226	23	78	20	160
6	3D	170-090-537	AS-HG-CV-65	Oval Hole	147	15	49	20	240
6	3D	170-090-540	AS-HG-CV-100	Type	226	23	76	20	160

Reference door weight (HG-CV65): 8kg
Reference door weight (HG-CV100): 13kg
(In case of door size W600×800, using 2 pcs vertically)

No.	Part Name	Material	Finish / Colour
①	Body	Aluminium Alloy	Anodised Silver
②	Cap	POM	White
-	Shaft	Stainless Steel (SUS303)	-

Refer to 1 : P.15

AS Parts Set For Installing to Aluminium Frame Please refer to the series introduction page 1 for details about AS series.



[Dimensions]

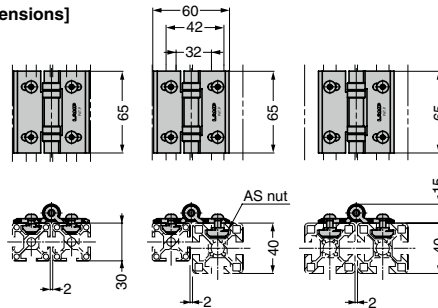

[AS Parts Set] Parts set of screws and AS nuts

R#HS	CAD	Item Code	Item Name	Aluminium Frame	Parts	Weight (g)
6	-	170-041-527	AS-HG-CV65-30-6	Groove width 6 mm	Hinge AS-HG-CV-65: 1 pc AS nut AS-6M4: 4 pcs Hexagon socket head cap screw M4×10: 4 pcs	-
6	-	170-041-528	AS-HG-CV65-30-8	Groove width 8 mm	Hinge AS-HG-CV-65: 1pc AS nut AS-8M5: 4 pcs	-
6	-	170-041-529	AS-HG-CV65-40-8		Hexagon socket head cap screw M5×14: 4 pcs	-
6	-	170-041-530	AS-HG-CV65-40-10	Groove width 10 mm	Hinge AS-HG-CV-65: 1pc AS nut AS-10M5: 4 pcs Hexagon socket head cap screw M5×14: 4 pcs	-
6	-	170-041-531	AS-HG-CV100-30-6	Groove width 6 mm	Hinge AS-HG-CV-100: 1 pc AS nut AS-6M4: 6 pcs Hexagon socket head cap screw M4×10: 6pcs	-
6	-	170-041-532	AS-HG-CV100-30-8	Groove width 8 mm	Hinge AS-HG-CV-100: 1pc AS nut AS-8M5: 6pcs	-
6	-	170-041-533	AS-HG-CV100-40-8		Hexagon socket head cap screw M5×14: 6pcs	-
6	-	170-041-534	AS-HG-CV100-40-10	Groove width 10 mm	Hinge AS-HG-CV-100: 1pc AS nut AS-10M5: 6pcs Hexagon socket head cap screw M5×14: 6pcs	-

Refer to 1 : FRONT P.20, 2 : P.706