

OVER THE TOP FLIPPER DOOR MECHANISM (W/ SOFT CLOSING)



OVN



Features

- For upward-opening flap doors.
- Built-in damper provides soft closing near closing radius, preventing slamming.
- Flap door retracts above cabinet top when opened, greatly reducing dead space.

Remarks

1 pair of OVN body and 2 pcs of C1315 rail (sold separately) are necessary for 1 cabinet.

Parts Included

Binding head tapping screw 3.5x16 (12 pcs)

Sold Separately

C1315 rail (below)

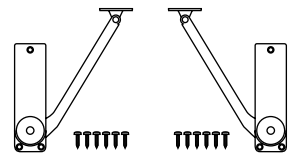
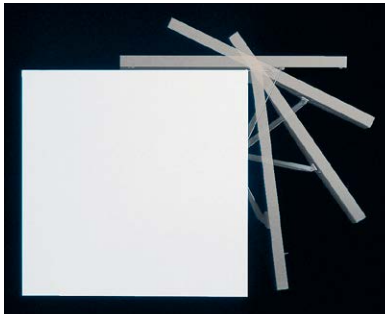

LID SUPPORTS

OVER THE TOP FLIPPER DOOR MECHANISM (W/ SOFT CLOSING)

Cut Out Dimensions

Cabinet cutaway view

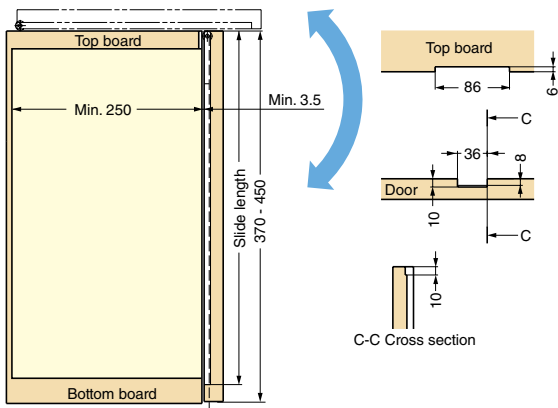

Cabinet front

(for travel length of C1315-14: 260 mm)

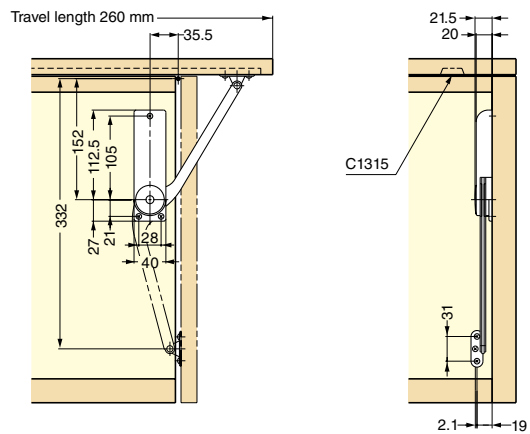

Item Code	Item Name	Material	Finish/Colour	Door Weight	Door Width	Door Height	Door Thickness	Weight	Carton
180-091-040	OVN-3	ABS/Steel	Black/Nickel	3 - 5 kg	Max. 1500	370 - 450	Min. 15	510 g	40 pairs
180-100-007	OVN-5	ABS/Steel	Black/Nickel	5 - 7 kg	Max. 1500	370 - 450	Min. 15	510 g	40 pairs

C1315 Rail (Sold Separately)

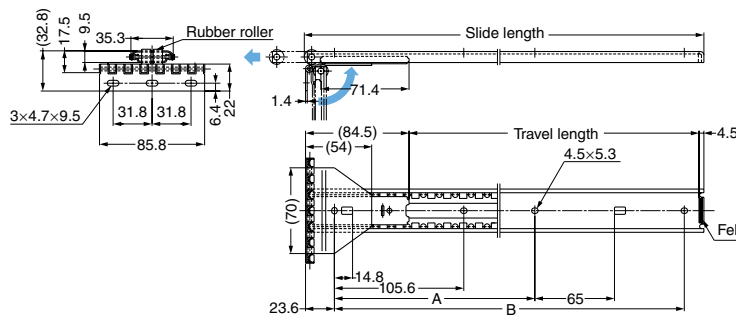

Item Code	Item Name	Material	Finish	Slide Length	Travel Length	A	B	Weight	Carton
190-113-849	C1315-14	Steel	Clear Zinc Chromate	350	260	186.7	310.5	320 g (1 pc)	20 pcs
190-113-850	C1315-18	Steel	Clear Zinc Chromate	450	360	286.7	410.5	390 g (1 pc)	20 pcs

2 pcs of C1315 rail are necessary for 1 cabinet.