

OVER THE TOP FLIPPER DOOR MECHANISM (W/ SOFT CLOSING)



OV-1



Features

- For forward-opening flap doors.
- Built-in damper provides soft closing near closing radius, preventing slamming.
- When pulling the flap door out horizontally, will hold its position.
- Flap door retracts above cabinet top and OV-1 is installed into frame, almost completely eliminating dead space.
- Closing speed is adjustable.
- Position adjustable post-installation ($\pm 1.5\text{mm}$)
- Ball bearing type slide rail provides smooth movement in rail section.

Remarks

2 pcs of OV1-MBP-BL-TRN-N2 (Main body) and 2 pcs of OV-SLP RN (Rail) are necessary for 1 cabinet.

Parts Included

- Installation plate (4 pcs)
- Countersunk head screw M4x26 for wooden door (8 pcs)
- Binding head screw M4x8 for metal door (8 pcs)
- Binding head tapping screw 4x10 for rail installation (12 pcs)

Installation Plate

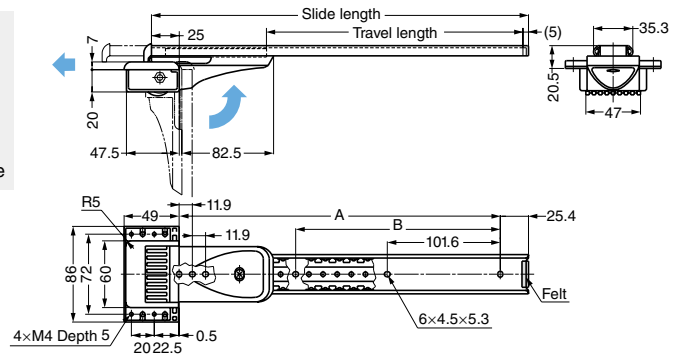

Cut Out Dimensions

Cabinet dimensions

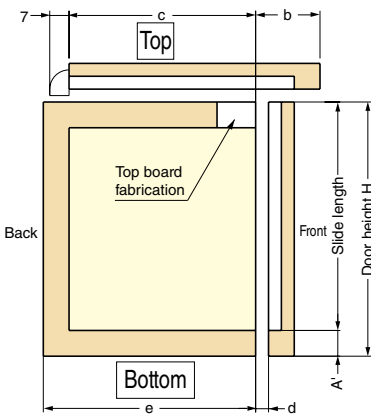

Door fabrication

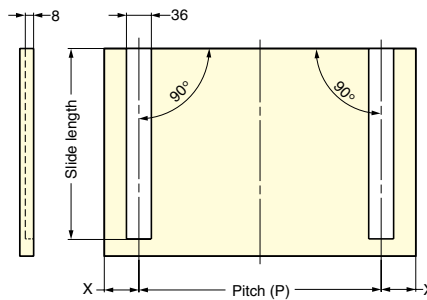

Top board fabrication

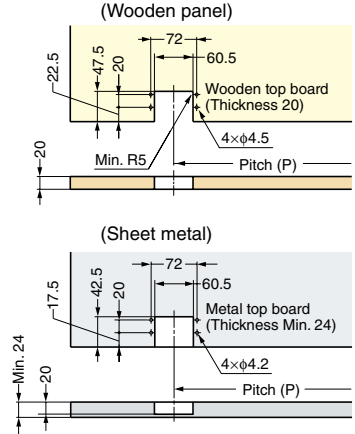

	b	c	d	e
Wooden Top Board	A'+81.4	H-b	2.5	Min. c+7
Metal Top Board	A'+86.4	H-b	7.5	Min. c+7

	X
Inset Application	80
Overlay Application	Side Board Thickness+80

Main Body: 2 pcs are necessary for 1 cabinet.

Item Code	Item Name	Material	Colour	Door Weight	Door Width	Door Height	Door Thickness	Torque Moment/set	Weight	Carton
180-109-206	OV1-MBP-BL-TRN-N2	Steel & Plastic	Black	3 - 5 kg	700 - 1400	350 - 450	Min. 20	5.9 - 9.8 N-m	60 - 100 kgf-cm	282 g / 40 pcs

Rail: 2 pcs are necessary for 1 cabinet.

Item Code	Item Name	Material	Finish	Slide Length	Travel Length	A	B	Weight	Carton
190-119-672	OV-13 SLP RN	Steel	Clear Zinc Chromate	330.2	223.8	279.4	177.8	270 g	20 pcs
190-119-673	OV-14 SLP RN	Steel	Clear Zinc Chromate	355.6	249.2	304.8	203.2	287 g	20 pcs
190-119-674	OV-15 SLP RN	Steel	Clear Zinc Chromate	381	274.6	330.2	228.6	310 g	20 pcs
190-119-675	OV-16 SLP RN	Steel	Clear Zinc Chromate	406.4	300	355.6	254	322 g	20 pcs

