

SPRING LOADED BARREL BOLT BLS With Position Fixing Function

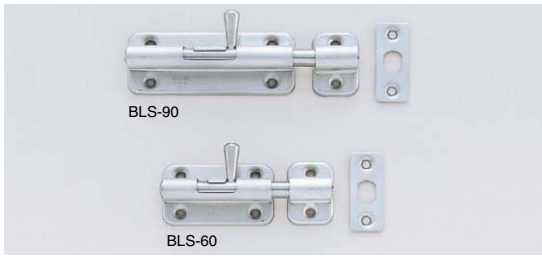

- Knob springs back into sleeve to keep bolt in locked or unlocked position.
- Can be installed vertically or horizontally.
- Two counter plates included for different mountings.

[Parts Included]

- Countersunk head wood screw 3.5×20 (SUS)

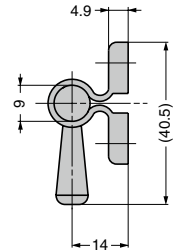
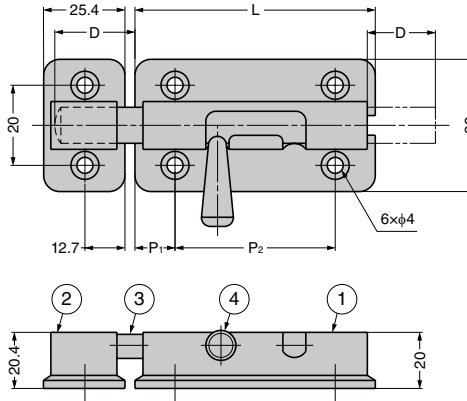
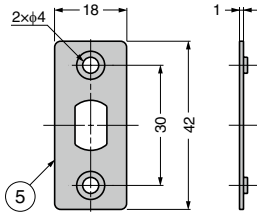

No.	Part Name	Material	Finish
①	Body	Stainless Steel (SUS304)	Satin
②	Strike	Stainless Steel (SUS304)	-
③	Bar	Stainless Steel (SUS303)	-
④	Knob	Stainless Steel (SUS303)	-
⑤	Counter Plate	Stainless Steel (SUS304)	Satin
-	Spring	Stainless Steel (SUS304)	-

RHS	CAD	Item Code	Item Name	L	P ₁	P ₂	D	Weight (g)	Box (pcs)	Carton (pcs)
G	3D	140-052-000	BLS-60	60	10	40	17	109	20	200
G	3D	140-052-001	BLS-90	90	12.5	65	24	147	15	150

SPRING LOADED BARREL BOLT BL-S With Position Fixing Function



- Knob springs back into sleeve to keep bolt in locked or unlocked position.
- Can be installed vertically or horizontally.
- Two counter plates included for different mountings.

[Parts Included]

- Countersunk head wood screw 2.7×16 (SUS)

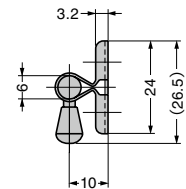
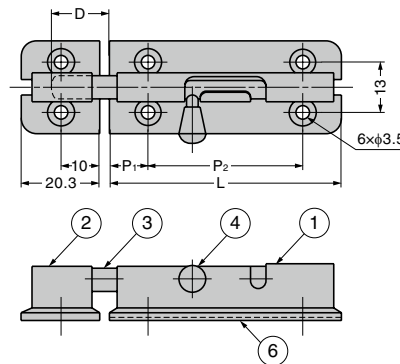
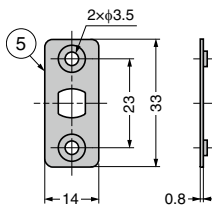

No.	Part Name	Material	Finish
①	Body	Stainless Steel (SUS304)	Satin
②	Strike	Stainless Steel (SUS304)	-
③	Bar	Stainless Steel (SUS303)	Plain
④	Knob	Stainless Steel (SUS303)	-
⑤	Counter Plate	Stainless Steel (SUS304)	Satin
⑥	Plate	Stainless Steel (SUS304)	Polished

RHS	CAD	Item Code	Item Name	L	P ₁	P ₂	D	Weight (g)	Box (pcs)	Carton (pcs)
G	3D	140-050-245	BL-40S	40	7.5	25	11	36	30	450
G	3D	140-050-246	BL-60S	60	10	40	15	50	30	450