

SEALED MAGNETIC CATCH

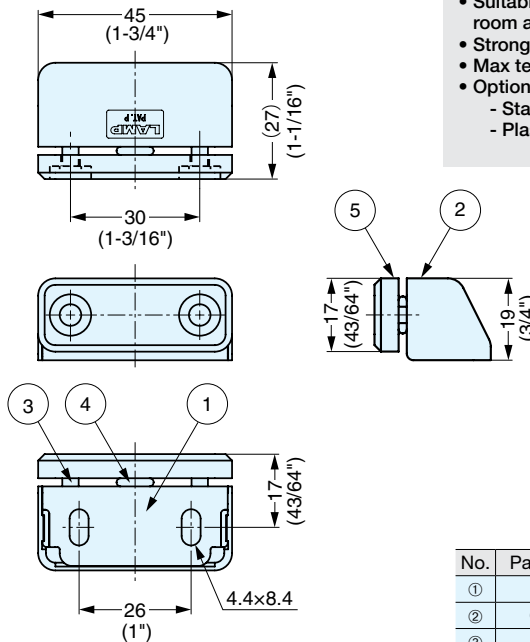

MC-JMS45WT



- Hermetically sealed, ideal for high corrosion environments.
- Magnetic face pivots for better contact with counterplate.
- Suitable for kitchen equipment and ideal for clean room applications.
- Strong magnetic force.
- Max temperature; 80°C (176°F)
- Optional counterplate sold separately:
 - Stainless Steel – MC-JMP49, AS-68
 - Plastic Sealed – MC-JMP45

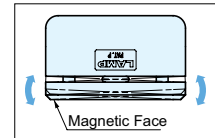

Magnetic face pivots to improve contact with counterplate.

No.	Part Name	Material	Finish
①	Body	304 Stainless Steel	Mirror
②	Cover	Polypropylene	White
③	Shaft	303 Stainless Steel	-
④	Ring	Rubber	Black
⑤	Magnet	Neodymium	-

Item No.	Magnetic Force (kg)	Weight (g)	Box (pcs)	Carton (pcs)
MC-JMS45WT	3 (6.6 lbs)	26	24	240

SEALED MAGNETIC CATCH (SNAP-IN TYPE)



MC-JMF54

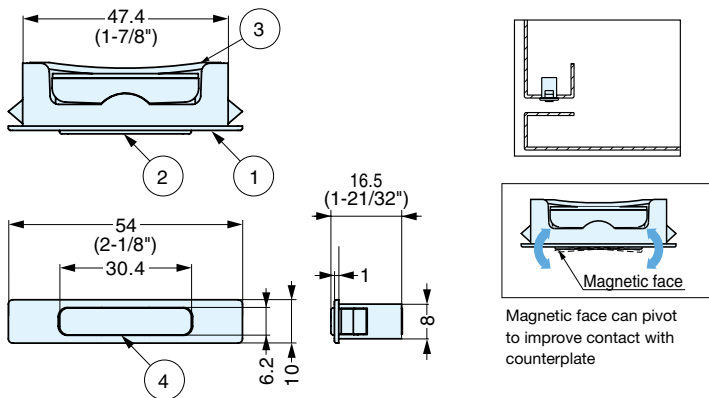
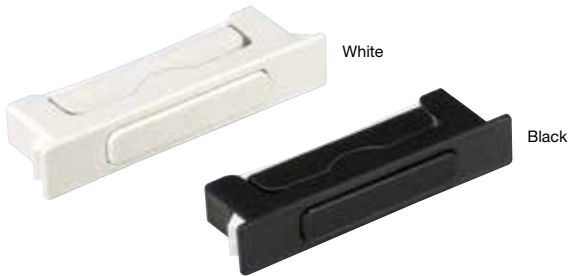

- Hermetically sealed, ideal for high corrosion environments.
- Magnetic face pivots for better contact with counterplate.
- Suitable for kitchen equipment and ideal for clean room applications.
- Strong magnetic force.
- Max temperature; 80 °C (176°F)
- Optional counterplate sold separately:
 - Stainless Steel – MC-JMP49, AS-68
 - Plastic Sealed – MC-JMP45

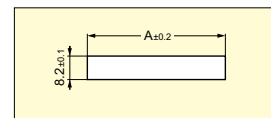

Cut Out Dimensions

Panel Thickness	A
0.7	48 (1-7/8")
0.8	
1.0	
1.2	
1.6	49(1-15/16")
2.0	50(1-31/32")

No.	Part Name	Material	Finish
①	Body	Polypropylene	Black/White
②	Cover		
③	Spring	Polyacetal	White
④	Magnet	Neodymium	Nickel

Item No.	Magnetic Force (kg)	Weight (g)	Box (pcs)	Carton (pcs)
MC-JMF54BL	2.6 (5.7 lbs)	13	25	1000
MC-JMF54WT				