

UNIT SHELF TYPE "B"

XLA-US02B

BRACKETS & SHELVING SYSTEM FOR GLASS UNIT SHELF XLA-US02B

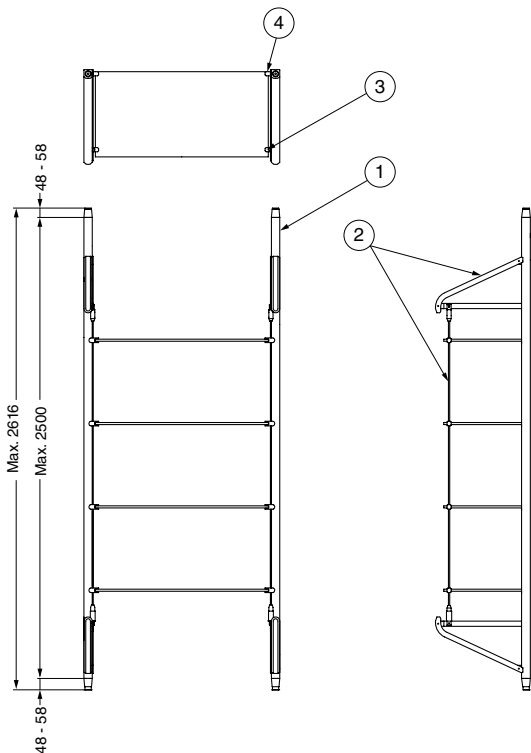

Load Capacity N		294 N/Shelf
Load Capacity kgf		30 kgf/Shelf
Glass Thickness		8 or 10
Glass Width	Glass Width: 8 mm	Max. 1200
	Glass Width: 10 mm	Max. 1500
Glass Depth		400 - 450
Vertical-Frame Height		2000 - 2500

Features

- Held in place by a rod, giving the impression that it is floating.
- Held in place firmly through the vertical frame
- Glass shelf ends go past the vertical frame giving a sleek appearance.
- Glass is secured by clamps attached to the frame, making it resistant to vibrations
- Shelf height can be adjusted freely.

Application

Showcases, displays in retail stores, walk in closets, residential interiors

XLA-US02B Parts Set (for 1 shelf)

Item Code	Item Name (set)	Weight
130-031-021	XLA-US02B	19.8 kg

• Parts Included

	Item Name	Part Name	Qty
①	XLA-US02-S006	Vertical Frame	2 sets
②	XL-US02-S011	Wire Kit	2 sets
③	XL-US01-F20	Shelf Clamp for Wire Shaft	8 pcs
④	XL-US01-B20	Shelf Clamp for Main Frame	8 pcs

Glass is not included.

Application Example



• Can be used as glass partition by installing glass panel at the back side.

BRACKETS & SHELVING SYSTEM

FOR GLASS

UNIT SHELF XLA-US02B

Glass Shelf Dimensions

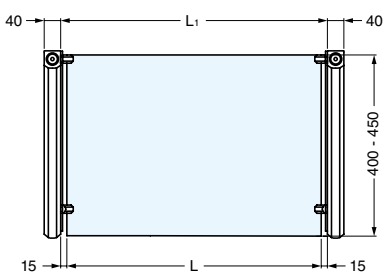

L (Glass width) = L₁ (Distance between frames) - 30

Back Panel Installation

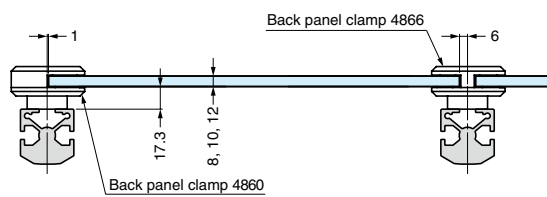

Glass Preparation (When Using LED)

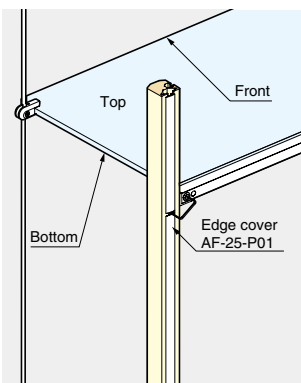

- Sandblasting on top, bottom, front and sides of glass shelf with use of LED will provide the "glow" look.
- Ultra clear glass recommended.
- Edge cover AF-25-P01 covers and keeps wires inside frame slot.