

FOLDING BRACKET BTO

SUS



- Folding type of bracket BT and BTK 1
- With locking lever to prevent unexpected folding.

[Remarks]

- When using as a bracket, be sure to lock the lever.
- Please hold the shelf board when folding. Improper use or applying load to it may cause accidental injury or damage.

[Parts Included]

- Raised countersunk head wood screw (see the table below for size and qty)

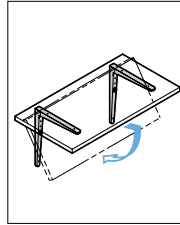
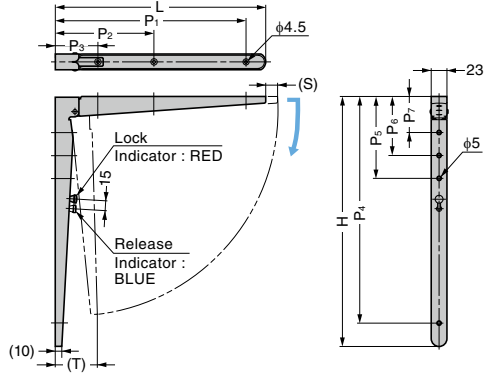

Item Name	Shelf Board		Wall	
	Size	Qty	Size	Qty
BTO-300	3.5 x 20	1 pc	4.5 x 25	1 pc
	3.8 x 38		4.5 x 45	2 pcs
BTO-380	3.5 x 25	1 pc	4.5 x 32	1 pc
	3.8 x 38		4.5 x 50	3 pcs
	3.8 x 45		-	-

Stainless steel (Plain) for BTO-300S, BTO-380S
Steel (White Enamel Finish) for BTO-300W, BTO-380W.

R/H/S	CAD	Item Code	Item Name	Material	Finish / Colour	H	L	P ₁	P ₂	P ₃	P ₄	P ₅	P ₆	P ₇	S	T	Load Capacity N/pc	Load Capacity kgf/pc	Weight (g)	Box (pcs)	Carton (pcs)
G	3D	120-014-937	BTO-300S	Stainless Steel (SUS304)	Satin	300	241	211	-	61	270	80	50	-	15	57	200	20.4	510	2	20
-	3D	120-030-091	BTO-300W	Steel	White Powder Coating	-	-	-	-	-	-	-	-	-	-	-	-	-	-	2	20
-	3D	-	☆ BTO-380S	Stainless Steel (SUS304)	Satin	380	320	290	150	65	345	125	90	55	18	64	-	-	-	-	-
-	3D	-	☆ BTO-380W	Steel	White Powder Coating	-	-	-	-	-	-	-	-	-	-	-	-	-	-	-	-

Refer to 1 : P.570

☆ Made to order with a minimum order of 2,000 pcs.

SPRING LOADED FOLDING BRACKET GTS-300

SUS



[Remarks]

- Please hold the shelf board when folding. Improper use or applying load to it may cause accidental injury or damage.
- Shelf board depth : Max. 450 mm.
- Horizontal use only.

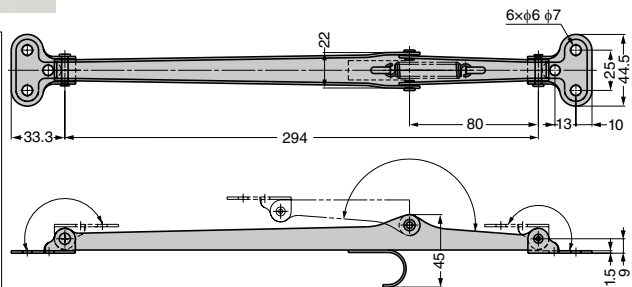
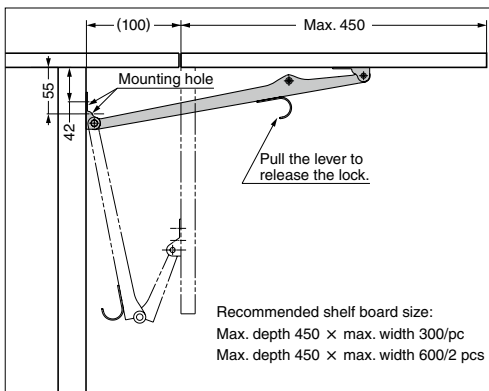

R/H/S	CAD	Item Code	Item Name	Material	Finish	Load Capacity N/pc	Load Capacity kgf/pc	Load Capacity N/ 2 pcs	Load Capacity kgf/2 pcs	Weight (g)	Box (pcs)	Carton (pcs)
G	3D	120-109-116	GTS-300	Stainless Steel (SUS304)	Polished	29.4	3	58.8	6	190	12	96