

CAM LOCK Million Lock Series

900



Features

- Suitable for vending machine, ATM and coin locker.
- Reversible key can be removed when locked (90° rotation).
- 1 million key changes available.
- Master Key system available at surcharge. (Max. 2,520 key changes/Master Key.)
- Other shapes of cam can be made to order.
- Keys can be shared with Million Lock Series.

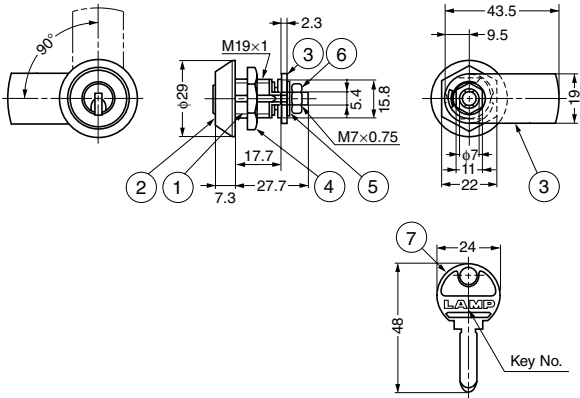

Cut Out Dimensions

(Standard type) (Master Key system type)

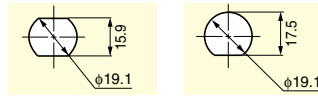

Installation

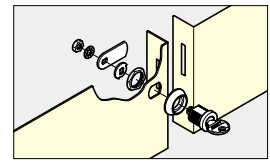

Item Code	Item Name	Key Type	Door Thickness	Weight	Box	Carton
150-060-247	900-B	Key Different	0.8 - 8	120 g	12 pcs	60 pcs
150-001-080	900-D	Key Alike	0.8 - 8	120 g	12 pcs	60 pcs

Please contact us for this item with Master Key system.

No.	Part Name	Material	Finish
①	Body	Brass	Chrome
②	Ring	Brass	Chrome
③	Cam	Steel	Yellow Zinc Chromate
④	Hex Nut	Steel	Yellow Zinc Chromate
⑤	Washer	Steel	Nickel
⑥	Hex Nut	Steel	Yellow Zinc Chromate
⑦	Key	Brass	Nickel

SECURITY CAM LOCK

DCY-34



Features

- Specially designed key provides security.
- Durability with thick cam.
- Reversible key can be removed when locked (90° rotation).
- Cam direction changeable.
- 2,000 key changes available.
- Master Key system available at surcharge. (Max. 866 key changes/Master Key.)

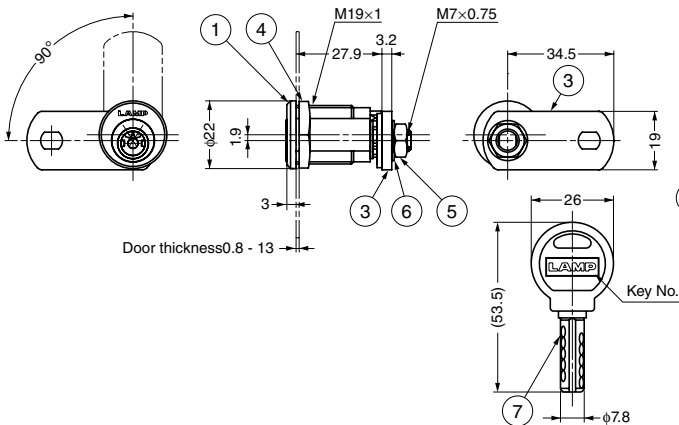

Cut Out Dimensions

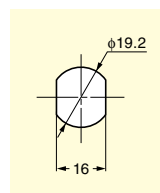

Installation

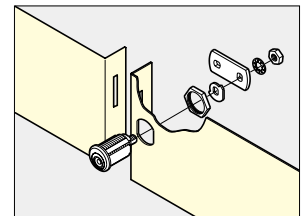

Item Code	Item Name	Key Type	Door Thickness	Weight
150-014-159	DCY-34-B	Key Different	0.8 - 13	101 g
150-014-158	DCY-34-D	Key Alike	0.8 - 13	101 g

Please contact us for this item with Master Key system.

No.	Part Name	Material	Finish/Colour
①	Body	Brass	Chrome
②	90° Cam	Steel (SPCC)	Yellow Zinc Chromate
③	Cam	Steel (SPCC)	Yellow Zinc Chromate
④	M19 Hex Nut	Steel (SS)	Yellow Zinc Chromate
⑤	M7 Hex Nut	Steel (SWCH)	Yellow Zinc Chromate
⑥	Inner Counter Plate	Steel (S65C)	Yellow Zinc Chromate
⑦	Key	Brass/ABS	Nickel/Black