

STAINLESS STEEL MINI SLIDE (2-WAY)

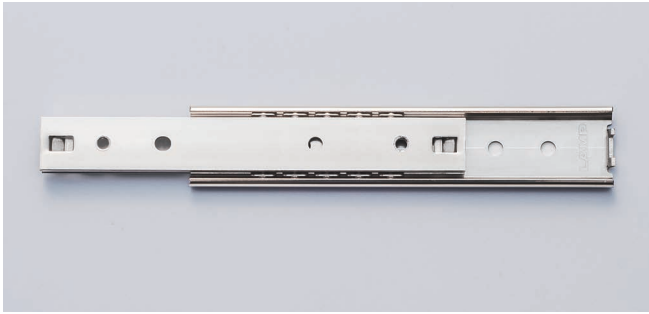

SCRW2



Features

- 3/4 extension (2 members).
- Ultra slim profile.
- Special inner member allows smooth movement.
- The drawer can be moved to both directions.

Recommended Screws

- M2.6 low head screw (for outer rail)
- M2.6 screw (for inner rail)
- Max. screw length = Board thickness + 1.5 mm

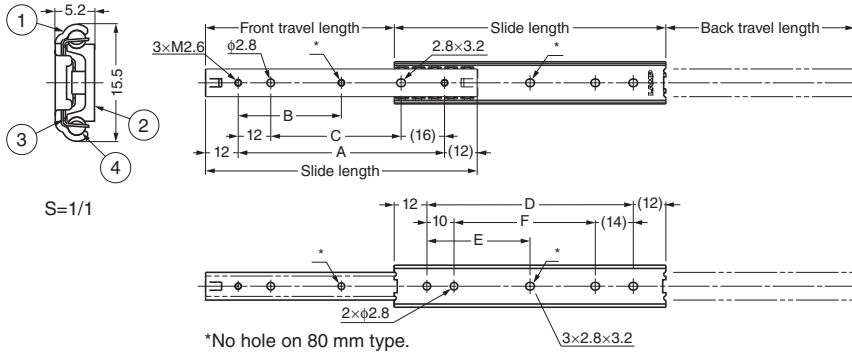

No.	Part Name	Material
①	Outer Rail	Stainless Steel (SUS304)
②	Inner Rail	Stainless Steel (SUS304)
③	Retainer	Stainless Steel (SUS304)
④	Balls	Steel

Sold by piece.

Item Code	Item Name	Slide Length	Front Travel Length	Back Travel Length	A	B	C	D	E	F	Load Capacity		Weight	Box	Carton
											N	kgf			
190-026-620	SCRW2-15- 80A	80	48.5	48.5	56	-	28	56	-	32	137 N/pair	14 kgf/pair	21 g	200 pcs	400 pcs
190-026-621	SCRW2-15-100A	100	68.5	68.5	76	38	48	76	38	52	157 N/pair	16 kgf/pair	26 g	200 pcs	400 pcs
190-026-622	SCRW2-15-150A	150	94.5	94.5	126	63	98	126	63	102	177 N/pair	18 kgf/pair	41 g	100 pcs	200 pcs

STAINLESS STEEL MINI GUIDE



SCRL2



Features

- Ultra slim profile.
- Special inner member allows smooth movement.

Recommended Screws

- M2.6 low head screw (for outer rail)
- M2.6 screw (for inner rail) Screw length = Panel thickness + Max. 1.5

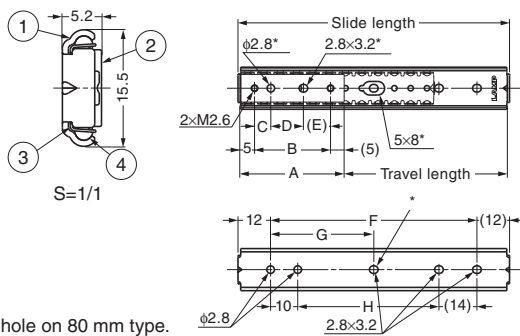

No.	Part Name	Material
①	Outer Rail	Stainless steel (SUS304)
②	Inner Rail	Stainless steel (SUS304)
③	Retainer	Stainless steel (SUS304)
④	Balls	Steel

Sold by piece.

Item Code	Item Name	Slide Length	Travel Length	A	B	C	D	E	F	G	H	Load Capacity		Weight	Box	Carton
												N	kgf			
190-026-623	SCRL2-15- 80A	80	49	28	18	-	-	-	56	-	32	177 N/pair	18 kgf/pair	16 g	200 pcs	400 pcs
190-026-624	SCRL2-15-100A	100	59	38	28	6	12	10	76	38	52	206 N/pair	21 kgf/pair	20 g	200 pcs	400 pcs
190-026-625	SCRL2-15-150A	150	109	38	28	6	12	10	126	63	102	206 N/pair	21 kgf/pair	29 g	100 pcs	200 pcs
190-026-626	SCRL2-15-200A	200	149	48	38	10	14	14	176	88	152	235 N/pair	24 kgf/pair	38 g	100 pcs	200 pcs



DRAWER SLIDES

STAINLESS STEEL MINI SLIDE (2-WAY) / STAINLESS STEEL MINI GUIDE