

SLIDING DOOR LATCH



HC-30L



- Sliding door latch with large lever for easy operation.
- Slim design suitable for various applications.
- Non-handed.
- For door thickness 28~48 mm (1-1/8"~1-9/16").
- For sliding doors only.

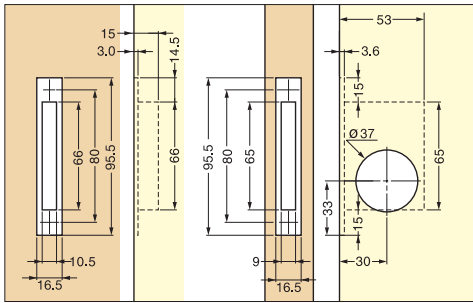

Bore Dimensions

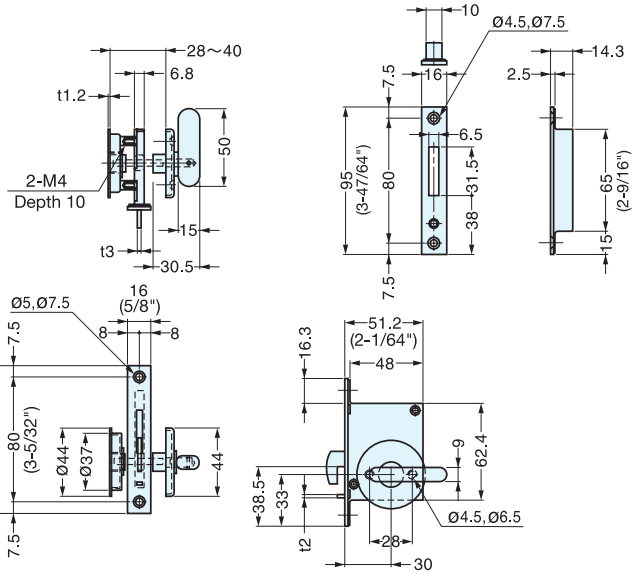

Item No.	Weight (g)	Box (pcs)	Carton (pcs)	Material	Finish
HC-30L	309	5	50	304 Stainless Steel, Brass, Zinc Alloy	Satin

SLIDING DOOR LATCH (W/INDICATOR)



HC-30HL



- Sliding door latch with indicator.
- Large lever for easy operation.
- Slim design suitable for various applications.
- Non-handed.
- For door thickness 28~48 mm (1-1/8"~1-9/16").
- For sliding doors only.

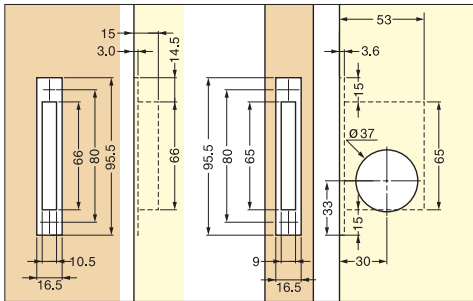

Bore Dimensions

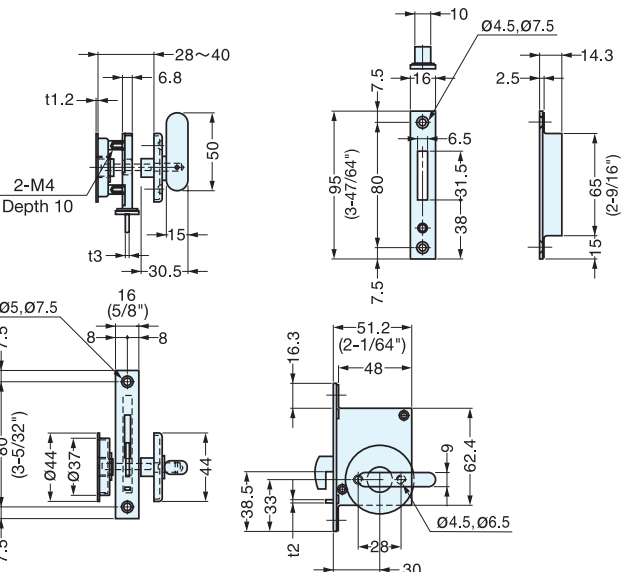

Item No.	Weight (g)	Box (pcs)	Carton (pcs)	Material	Finish
HC-30HL	309	5	50	304 Stainless Steel, Brass, Zinc Alloy	Satin