



STAINLESS STEEL LEVELING GLIDE

ADWS, ADWHS



ADWS

ADWHS

Features

- 304 stainless steel for rust and corrosion resistance.
- ADWS : Excellent weather resistance.
- ADWHS : Base material helps to prevent marking on the floor and has excellent heat / weather resistance.

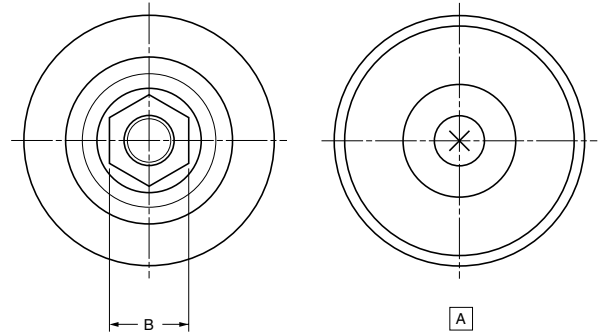

Application Example

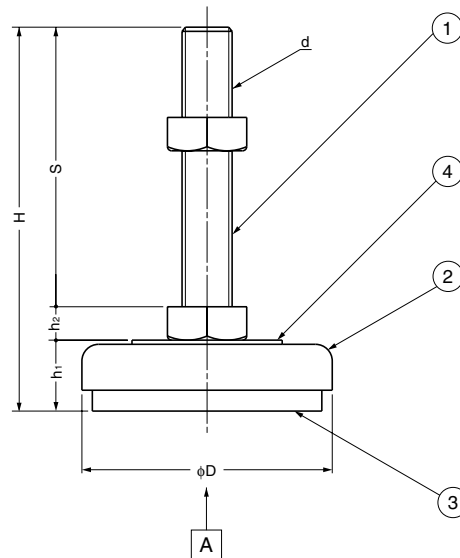
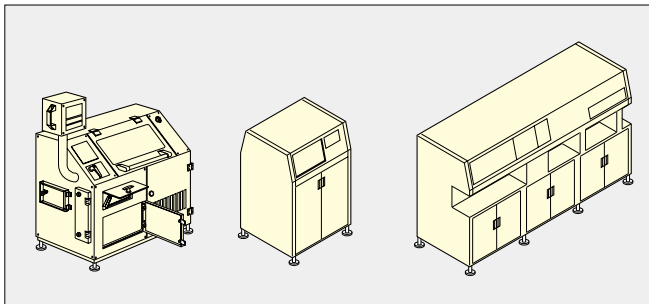

No.	Part Name	Material	Finish/Colour
①	Threaded Bolt	Stainless Steel (SUS304)	Satin
②	Cover	Stainless Steel (SUS304)	Satin
③	Base	ADWS/Chloroprene Rubber (CR)	Black
		ADWHS/Ethylene Propylene Rubber (EPDM)	White
④	Washer	Polyamide (PA)	-

Item Code	Item Name	d	D	H	h ₁	h ₂	S	B	Load Capacity		Weight	Carton
200-140-605	ADWS 40- 8- 60	M 8	40	78.5	13	5.5	60	13	3724 N	380 kgf	75 g	150 pcs
200-140-606	ADWS 40-10- 50	M10	40	70	13	7	50	17	6272 N	640 kgf	95 g	120 pcs
200-140-607	ADWS 50-12- 70	M12	50	93	15	8	70	19	8722 N	890 kgf	176 g	60 pcs
200-140-609	ADWS 50-12-120	M12	50	143	15	8	120	19	7644 N	780 kgf	216 g	60 pcs
200-140-611	ADWS 60-16- 70	M16	60	97	17	10	70	24	14308 N	1460 kgf	292 g	40 pcs
200-140-612	ADWS 60-16-100	M16	60	127	17	10	100	24	14210 N	1450 kgf	332 g	35 pcs
200-140-616	ADWS 60-20-100	M20	60	130	17	13	100	30	17150 N	1750 kgf	484 g	25 pcs
200-140-617	ADWS 60-20-130	M20	60	160	17	13	130	30	15876 N	1620 kgf	570 g	20 pcs
200-140-620	ADWHS40- 8- 60	M 8	40	78.5	13	5.5	60	13	4214 N	430 kgf	73 g	150 pcs
200-140-621	ADWHS40-10- 50	M10	40	70	13	7	50	17	5978 N	610 kgf	96 g	120 pcs
200-140-622	ADWHS50-12- 70	M12	50	93	15	8	70	19	8330 N	850 kgf	167 g	60 pcs
200-140-627	ADWHS60-16-100	M16	60	127	17	10	100	24	12348 N	1260 kgf	336 g	35 pcs
200-140-628	ADWHS60-16-130	M16	60	157	17	10	130	24	11760 N	1200 kgf	377 g	30 pcs