

LEVELING GLIDE

TEST
METHOD 14

MN



Features

- Leveling glide with plastic base to prevent from scratching the floor.
- Swivels approximately 8° to compensate for uneven floors.

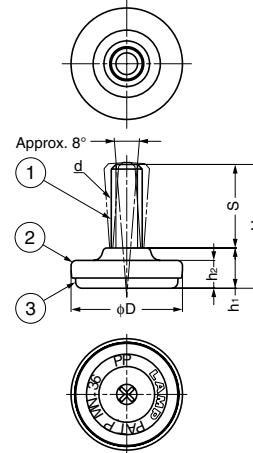

No.	Part Name	Material	Finish/Colour
①	Threaded Bolt	Steel	Chrome
②	Cover	Stainless Steel (SUS304)	-
③	Base	Polypropylene (PP)	Natural

Item Code	Item Name	d	D	H	h ₁	h ₂	S	Load Capacity N	Load Capacity kgf	Weight	Box	Carton
200-140-401	MN-25M8	M8	25	40	13	9	27	1176 N	120 kgf	26 g	100 pcs	600 pcs
200-140-400	MN-25N2.5	W5/16	25	40	13	9	27	1176 N	120 kgf	26 g	100 pcs	600 pcs
200-140-403	MN-32M10	M10	32	40	13	9	27	1568 N	160 kgf	34 g	80 pcs	480 pcs
200-140-402	MN-32N3	W3/8	32	40	13	9	27	1568 N	160 kgf	34 g	80 pcs	480 pcs
200-140-405	MN-36M10	M10	36	40	13	9	27	1568 N	160 kgf	39 g	60 pcs	360 pcs
200-140-404	MN-36N3	W3/8	36	40	13	9	27	1568 N	160 kgf	39 g	60 pcs	360 pcs
200-140-407	MN-40M10	M10	40	40	13	9	27	1568 N	160 kgf	42 g	50 pcs	300 pcs
200-140-406	MN-40N3	W3/8	40	40	13	9	27	1568 N	160 kgf	42 g	50 pcs	300 pcs
200-140-409	MN-50M12	M12	50	50	16	11	34	1568 N	160 kgf	77 g	20 pcs	120 pcs
200-140-408	MN-50N4	W1/2	50	50	16	11	34	1568 N	160 kgf	77 g	20 pcs	120 pcs

LEVELING GLIDE

TEST
METHOD 14

TN



Features

- Leveling glide with plastic base to prevent from scratching the floor.

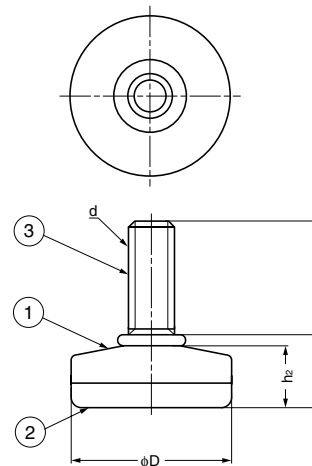

No.	Part Name	Material	Finish/Colour
①	Body	Steel	Chrome
②	Base	Polypropylene (PP)	Natural
③	Threaded Bolt	Steel	Yellow Zinc Chromate

Item Code	Item Name	d	D	h ₁	h ₂	S	Load Capacity N	Load Capacity kgf	Weight	Box	Carton
200-140-246	TN-25	M8	25	15	12	25	784 N	80 kgf	20 g	100 pcs	1,000 pcs
200-140-247	TN-35	M10	35	16.5	13.5	25	980 N	100 kgf	30 g	50 pcs	500 pcs
200-140-248	TN-45	M10	43.5	16.5	13.5	32	980 N	100 kgf	40 g	40 pcs	400 pcs