

SELF-LEVELING GLIDE

SAJ



Features

- Gel inside adjusts automatically to uneven floor.
- Self adjustment up to 3 mm or 6 mm.
- Suited for environments between -20°C and 75°C.

SAJ-WRENCH (Sold Separately)



Wrench (Sold Separately)				
Item Code	Item Name	Nominal	Thickness	
A	200-140-390	SAJ10	10	1.6
B	200-140-391	SAJ13	13	2.0
C	200-140-392	SAJ14	14	2.0
D	200-140-393	SAJ17	17	2.2

CASTERS & LEVELING GLIDES

SELF-LEVELING GLIDE

Installation

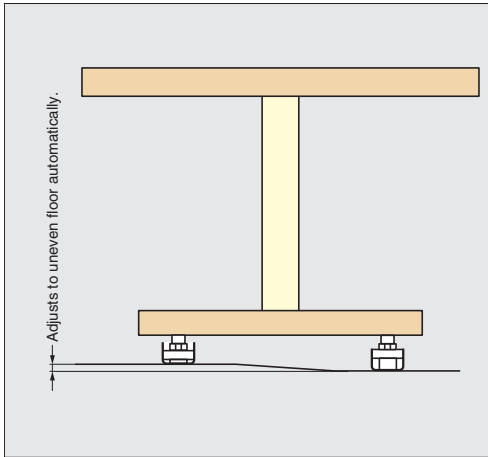

Self Adjustment

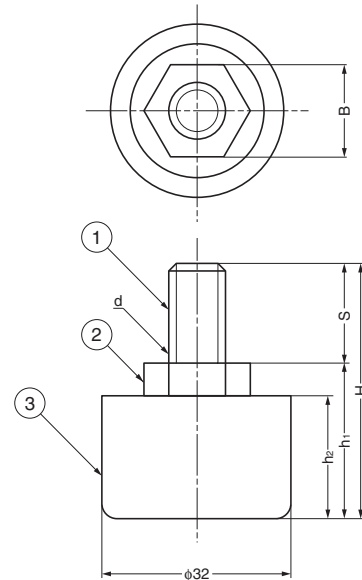
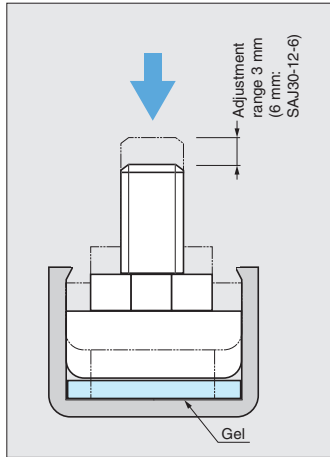

No.	Part Name	Material	Finish/Colour
①	Threaded Bolt	Steel (SWCH)	※ Yellow Zinc Chromate/SAJ30-10
②	Hex Nut		※ Clear Zinc Chromate/SAJ30-12
③	Cover	Polyethylene (PE)	Black

※The finishes will be clear zinc chromate (trivalent) when the current stock runs out.

Item Code	Item Name	Wrench	d	H	h ₁	h ₂	S	B	Load Capacity	Appropriate Table Weight			Weight	Box	Carton	
										4 pcs	5 pcs	6 pcs				
200-149-309	SAJ30-10N2.5	C	W5/16	33	24	19	9	14	490 N	50 kgf	7 - 12 kg	8 - 15 kg	10 - 18 kg	26 g	40 pcs	400 pcs
200-149-308	SAJ30-10N3	D	W3/8	37	25	19	12	17	490 N	50 kgf	7 - 12 kg	8 - 15 kg	10 - 18 kg	36 g	40 pcs	400 pcs
200-149-307	SAJ30-10M6	A	M6	34	24	19	10	10	490 N	50 kgf	7 - 12 kg	8 - 15 kg	10 - 18 kg	21 g	40 pcs	400 pcs
200-149-306	SAJ30-10M8	B	M8	33	24	19	9	13	490 N	50 kgf	7 - 12 kg	8 - 15 kg	10 - 18 kg	25 g	40 pcs	400 pcs
200-149-305	SAJ30-10M10	D	M10	37	26	19	11	17	490 N	50 kgf	7 - 12 kg	8 - 15 kg	10 - 18 kg	38 g	40 pcs	400 pcs
200-149-304	SAJ30-12N2.5	C	W5/16	33	24	19	9	14	490 N	50 kgf	12 - 24 kg	15 - 30 kg	18 - 36 kg	26 g	40 pcs	400 pcs
200-149-303	SAJ30-12N3	D	W3/8	37	25	19	12	17	490 N	50 kgf	12 - 24 kg	15 - 30 kg	18 - 36 kg	36 g	40 pcs	400 pcs
200-149-302	SAJ30-12M6	A	M6	34	24	19	10	10	490 N	50 kgf	12 - 24 kg	15 - 30 kg	18 - 36 kg	21 g	40 pcs	400 pcs
200-149-301	SAJ30-12M8	B	M8	33	24	19	9	13	490 N	50 kgf	12 - 24 kg	15 - 30 kg	18 - 36 kg	25 g	40 pcs	400 pcs
200-149-300	SAJ30-12M10	D	M10	37	26	19	11	17	490 N	50 kgf	12 - 24 kg	15 - 30 kg	18 - 36 kg	38 g	40 pcs	400 pcs
200-140-105	SAJ30-12-6N2.5	C	W5/16	42	31	24	11	14	490 N	50 kgf	12 - 24 kg	15 - 30 kg	18 - 36 kg	29 g	40 pcs	400 pcs
200-140-104	SAJ30-12-6N3	D	W3/8	42	31	24	11	17	490 N	50 kgf	12 - 24 kg	15 - 30 kg	18 - 36 kg	39 g	40 pcs	400 pcs
200-140-103	SAJ30-12-6M6	A	M6	44	32	24	12	10	490 N	50 kgf	12 - 24 kg	15 - 30 kg	18 - 36 kg	29 g	40 pcs	400 pcs
200-140-102	SAJ30-12-6M8	B	M8	42	32	24	10	13	490 N	50 kgf	12 - 24 kg	15 - 30 kg	18 - 36 kg	22 g	40 pcs	400 pcs
200-140-101	SAJ30-12-6M10	D	M10	41	31	24	10	17	490 N	50 kgf	12 - 24 kg	15 - 30 kg	18 - 36 kg	41 g	40 pcs	400 pcs