

LEVELING GLIDE

TEST
METHOD 14

TN-S



Features

Leveling glide with plastic base to prevent from scratching the floor.

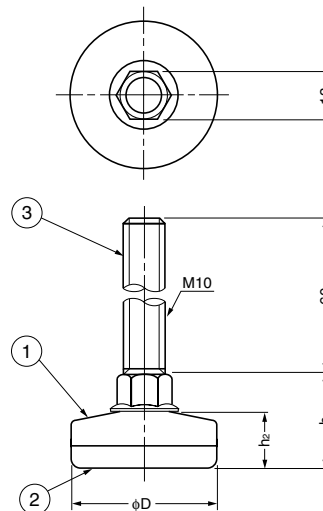

No.	Part Name	Material	Finish/Colour
①	Body	Steel	Chrome
②	Base	Polypropylene (PP)	Natural
③	Threaded Bolt	Steel	Zinc Chromate

Item Code	Item Name	D	h ₁	h ₂	Load Capacity N	Load Capacity kgf	Weight	Box	Carton
200-140-249	TN-25S	25	21	12	1372 N	140 kgf	50 g	50 pcs	500 pcs
200-140-250	TN-35S	35	22.5	13.5	1372 N	140 kgf	60 g	30 pcs	300 pcs
200-140-251	TN-45S	43.5	22.5	13.5	1372 N	140 kgf	70 g	20 pcs	200 pcs

LEVELING GLIDE

TEST
METHOD 14

AD-501

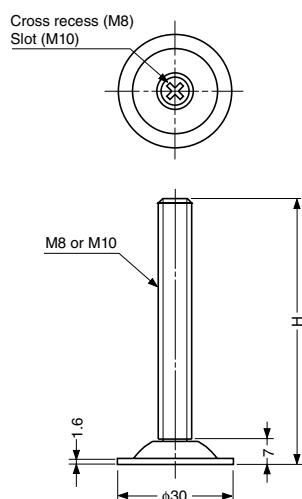

Features

- Use with glide bases.
- Height is adjustable by a screw driver.

M8 Type

Item Code	Item Name	H	Load Capacity N	Load Capacity kgf	Weight	Box	Carton
200-140-060	AD-501- 30E	30	980 N	100 kgf	17 g	100 pcs	400 pcs
200-140-580	AD-501- 50E	50	980 N	100 kgf	22 g	100 pcs	400 pcs
200-140-057	AD-501- 60E	60	980 N	100 kgf	25 g	100 pcs	400 pcs
200-140-581	AD-501- 70E	70	980 N	100 kgf	28 g	50 pcs	200 pcs
200-140-582	AD-501- 75E	75	980 N	100 kgf	30 g	50 pcs	200 pcs
200-140-583	AD-501- 80E	80	980 N	100 kgf	31 g	50 pcs	200 pcs
200-140-056	AD-501- 90E	90	980 N	100 kgf	35 g	50 pcs	200 pcs
200-140-584	AD-501-105E	105	980 N	100 kgf	38 g	50 pcs	200 pcs
200-140-585	AD-501-120E	120	980 N	100 kgf	43 g	50 pcs	200 pcs
200-140-586	AD-501-130E	130	980 N	100 kgf	45 g	50 pcs	200 pcs

M10 Type

Item Code	Item Name	H	Load Capacity N	Load Capacity kgf	Weight	Box	Carton
200-140-061	AD-501- 30G	30	1372 N	140 kgf	20 g	100 pcs	400 pcs
200-140-063	AD-501- 60G	60	1372 N	140 kgf	37 g	100 pcs	400 pcs
200-140-590	AD-501- 90G	90	1372 N	140 kgf	50 g	50 pcs	200 pcs
200-140-591	AD-501-120G	120	1372 N	140 kgf	65 g	50 pcs	200 pcs

Material	Finish
Steel	Zinc Chromate