

LEVELLING GLIDE SG With Swivel Function

LOAD CAPACITY 1176~1568 N
TEST METHOD 14

SG-40M8

SG-32M8

- Swivels approximately 20° to compensate for uneven floors.

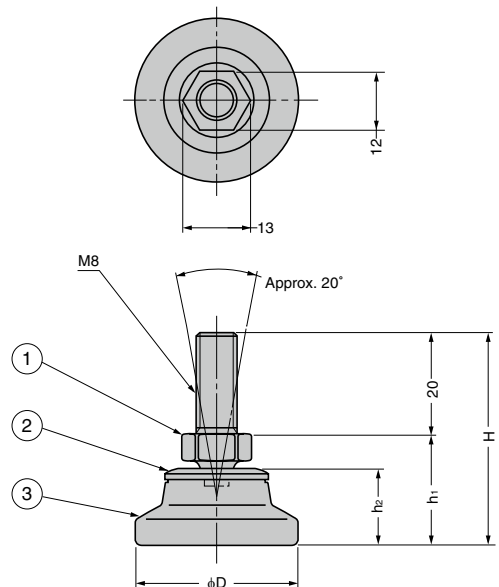

No.	Part Name	Material	Finish/Colour
①	Threaded Bolt	Steel (SWCH)	Black Chromate
②	Cap	PA	Dark Grey
③	Base	POM	

RoHS	CAD	Item Code	Item Name	D	H	h ₁	h ₂	Load Capacity N/pc	Load Capacity kgf/pc	Weight (g)	Box (pcs)	Carton (pcs)
G	BD	200-142-506	SG-32M8	32	42	22	15.5	1176	120	25	60	480
G	BD	200-142-504	SG-40M8	40	42.5	22.5	16	1568	160	30	35	210

OCTAGONAL LEVELLING GLIDE MK8AD With Swivel Function

LOAD CAPACITY 588 N
TEST METHOD 14

- Swivels approximately 10° to compensate for uneven floors.
- With swivel function to distribute the load evenly for excellent durability.
- Slotted top of threaded bolt and hexagon socket at the bottom allows easy installation and adjustment.
- Octagonal base allows easy adjustment by hand or wrench (width across flats: 24 mm).
- Double structure of cover/bolt and base allow easy height adjustment without lifting the leg.
- Levelling glide with elastomer base to prevent from skidding.

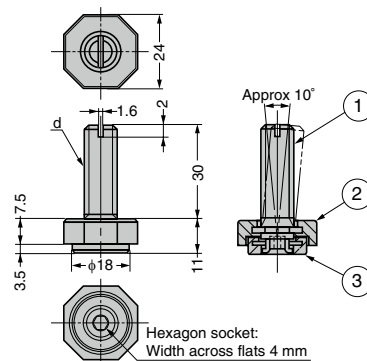

No.	Part Name	Material	Finish/Colour
①	Threaded Bolt	Steel (SWCH)	Black Chromate (Trivalent)
②	Cover	PA	Black
③	Base	Elastomer (TPE)	

RoHS	CAD	Item Code	Item Name	Old Item Name	d	Load Capacity N/pc	Load Capacity kgf/pc	Weight (g)	Box (pcs)	Carton (pcs)
G	BD	200-018-798	MK8AD-M8	—	M8	588	60	18	80	480
G	BD	200-140-039	MK8AD-M10	MK8AD	M10			20	80	480