

LEVELING GLIDE

MKR-N



Features

- Swivels approximately 10° to compensate for uneven floors.
- Double structure of cover/bolt and base allows easy height adjustment without lifting the leg.
- Leveling glide with elastomer base to prevent from skidding.

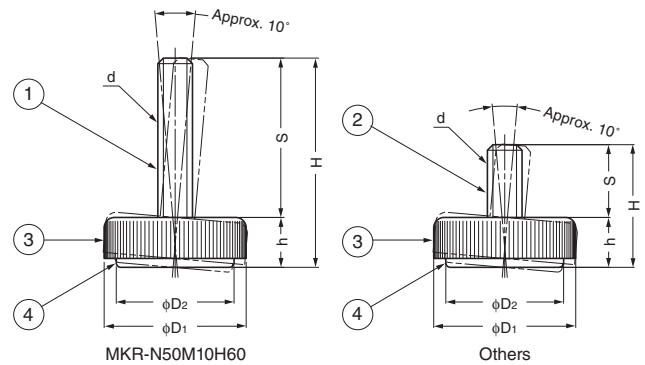

No.	Part Name	Material	Finish/Colour
①	Threaded Bolt	Steel	Yellow Zinc Chromate
②	Threaded Bolt	Steel	Chrome
③	Cover	Polyamide (PA)	Black
④	Base	Elastomer (TPO)	Black

Item Code	Item Name	d	D ₁	D ₂	H	h	S	Load Capacity N	Load Capacity kgf	Weight	Box	Carton
200-141-300	MKR-N32M10	M10	33	27	36	14	22	588 N	60 kgf	35 g	80 pcs	480 pcs
200-141-301	MKR-N32N3	W3/8	33	27	36	14	22	588 N	60 kgf	35 g	80 pcs	480 pcs
200-141-302	MKR-N40M10	M10	41	34	37	15	22	686 N	70 kgf	45 g	50 pcs	300 pcs
200-141-303	MKR-N40N3	W3/8	41	34	37	15	22	686 N	70 kgf	40 g	50 pcs	300 pcs
200-141-304	MKR-N50M10	M10	51	44	37.5	15.5	22	784 N	80 kgf	60 g	20 pcs	120 pcs
200-140-100	MKR-N50M10H60	M10	51	44	60	15.5	44.5	784 N	80 kgf	60 g	20 pcs	120 pcs
200-141-305	MKR-N50N3	W3/8	51	44	37.5	15.5	22	784 N	80 kgf	55 g	20 pcs	120 pcs

LEVELING GLIDE

MKR-N32



Features

- Swivels approximately 10° to compensate for uneven floors.
- Double structure of cover/bolt and base allows easy height adjustment without lifting the leg.
- Leveling glide with elastomer base to prevent from skidding and scratching the floor.

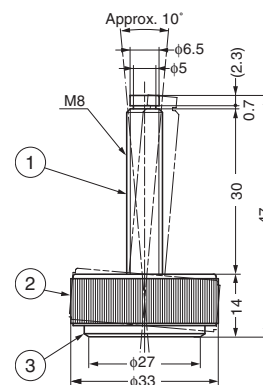

Application Example

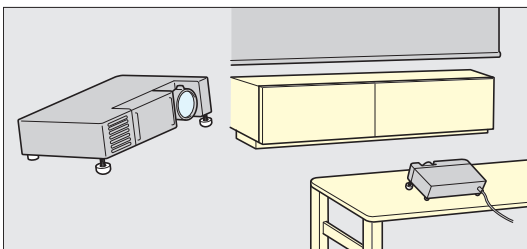

No.	Part Name	Material	Finish/Colour
①	Threaded Bolt	Steel	Chrome
②	Cover	Polyamide (PA)	Dark Grey, Grey
③	Base	Elastomer (TPO)	Black

Item Code	Item Name	Colour	Load Capacity N	Load Capacity kgf	Weight	Box	Carton
200-149-228	MKR-N32DG32	Dark Grey	454 N	46 kgf	31 g	50 pcs	300 pcs