

TWIN WHEEL CASTER (PLATE TYPE)

GX60P



Features

- Thanks to the light weight aluminium body, the caster is strong and smart looking.
- Twin wheel caster with excellent stability.

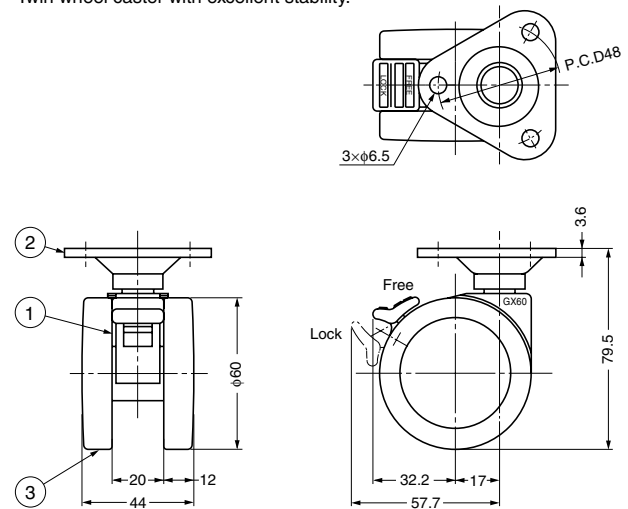

No.	Part Name	Material	Finish/Colour
①	Body	Aluminium Alloy	Polished
②	Plate	Steel	Zinc Chromate
③	Wheel	Polyamide (PA)	Black

Item Code	Item Name	Type	Load Capacity N	Load Capacity kgf	Weight	Box	Carton
200-133-181	GX60PS	With Brake	1470 N	150 kgf	246 g	4 pcs	60 pcs
200-130-033	GX60P	Without Brake	1470 N	150 kgf	246 g	4 pcs	60 pcs

TWIN WHEEL CASTER (THREADED BOLT TYPE)

GX60N12



Features

- Thanks to the light weight aluminium body, the caster is strong and smart looking.
- Twin wheel caster with excellent stability.

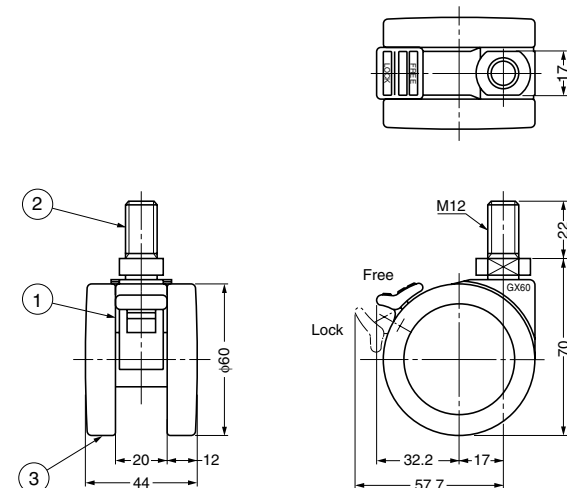

No.	Part Name	Material	Finish/Colour
①	Body	Aluminium Alloy	Polished
②	Threaded Bolt	Steel	Zinc Chromate
③	Wheel	Polyamide (PA)	Black

Item Code	Item Name	Type	Load Capacity N	Load Capacity kgf	Weight	Box	Carton
200-133-183	GX60N12S	With Brake	1470 N	150 kgf	185 g	4 pcs	60 pcs
200-133-182	GX60N12	Without Brake	1470 N	150 kgf	180 g	4 pcs	60 pcs