

TWIN WHEEL CASTER (PLATE TYPE)

FA45P



Features

Thanks to the light weight aluminium body, the caster is strong and smart looking.

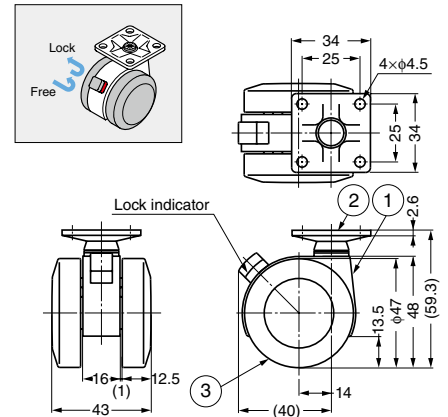

Item Code	Item Name	Type	Load Capacity N	Load Capacity kgf	Weight	Box	Carton
200-133-213	FA45PSR	With Brake	490 N	50 kgf	117 g	4 pcs	100 pcs
200-133-212	FA45PR	Without Brake	490 N	50 kgf	113 g	4 pcs	100 pcs

No.	Part Name	Material	Finish/Colour
①	Body	Aluminium Alloy	Silver
②	Plate	Steel	Zinc Chromate
③	Wheel	Polyamide (PA)	Black

TWIN WHEEL CASTER (THREADED BOLT TYPE)

FA45N



Features

Thanks to the light weight aluminium body, the caster is strong and smart looking.

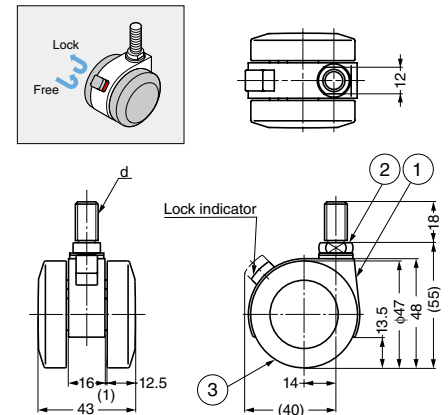

Item Code	Item Name	Type	d	Load Capacity N	Load Capacity kgf	Weight	Box	Carton
200-133-211	FA45N 3SR	With Brake	W3/8	490 N	50 kgf	100 g	4 pcs	100 pcs
200-133-210	FA45N 3R	Without Brake	W3/8	490 N	50 kgf	97 g	4 pcs	100 pcs
200-133-215	FA45N10SR	With Brake	M10	490 N	50 kgf	100 g	4 pcs	100 pcs
200-133-209	FA45N10R	Without Brake	M10	490 N	50 kgf	97 g	4 pcs	100 pcs

No.	Part Name	Material	Finish/Colour
①	Body	Aluminium Alloy	Silver
②	Threaded Bolt	Steel	Zinc Chromate
③	Wheel	Polyamide (PA)	Black

TWIN WHEEL CASTER (INSERT BOLT TYPE)

FA45S



Features

Thanks to the light weight aluminium body, the caster is strong and smart looking.

Parts Included

Socket

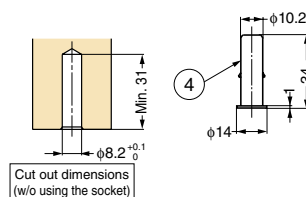
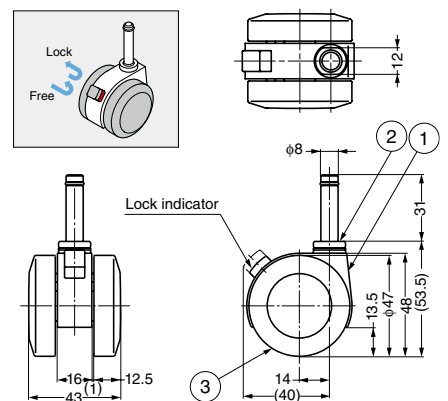

Item Code	Item Name	Type	Load Capacity N	Load Capacity kgf	Weight	Box	Carton
200-130-901	FA45SSR	With Brake	490 N	50 kgf	102 g	4 pcs	100 pcs
200-130-902	FA45SR	Without Brake	490 N	50 kgf	100 g	4 pcs	100 pcs

No.	Part Name	Material	Finish/Colour
①	Body	Aluminium Alloy	Silver
②	Insert Bolt	Steel	Zinc Chromate
③	Wheel	Polyamide (PA)	Black
④	Socket	Steel	Zinc Chromate