

TWIN WHEEL CASTER (PLATE TYPE)

GX-W50GP

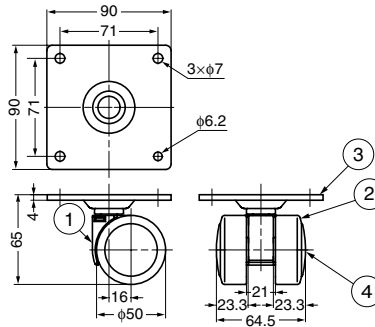
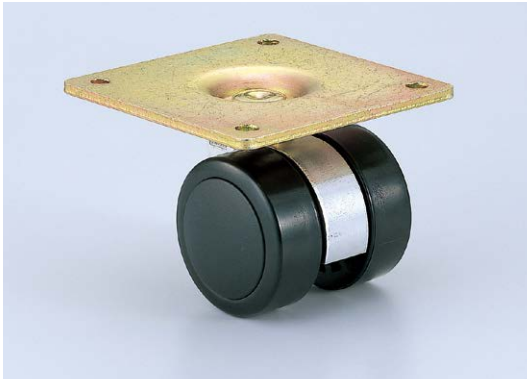

Features

- Thanks to the light weight aluminium body, the caster is strong and smart looking.
- Twin wheel caster with excellent stability.
- Use in combination with GX-W50K (Non-swivel type) for easy handling.

No.	Part Name	Material	Finish/Colour
①	Body	Aluminium Alloy	Polished
②	Wheel	Polyacetal (POM)	Black
③	Plate	Steel	Yellow Zinc Chromate
④	Cover	Polyamide (PA)	Black

Item Code	Item Name	Load Capacity N	Load Capacity kgf	Weight	Box	Carton
200-130-027	GX-W50GP	1960 N	200 kgf	442 g	2 pcs	40 pcs

TWIN WHEEL CASTER (THREADED BOLT TYPE)

GX-W50GN

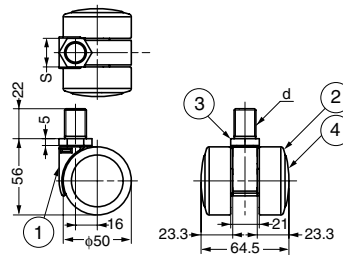

Features

- Thanks to the light weight aluminium body, the caster is strong and smart looking.
- Twin wheel caster with excellent stability.

No.	Part Name	Material	Finish/Colour
①	Body	Aluminium Alloy	Polished
②	Wheel	Polyacetal (POM)	Black
③	Threaded Bolt	Steel	Yellow Zinc Chromate
④	Cover	Polyamide (PA)	Black

Item Code	Item Name	d	S	Load Capacity N	Load Capacity kgf	Weight	Box	Carton
200-130-028	GX-W50GN12	M12	19	1960 N	200 kgf	208 g	4 pcs	80 pcs
200-130-029	GX-W50GN16	M16	21	1960 N	200 kgf	223 g	4 pcs	80 pcs

TWIN WHEEL CASTER (NON-SWIVEL PLATE TYPE)

GX-W50K

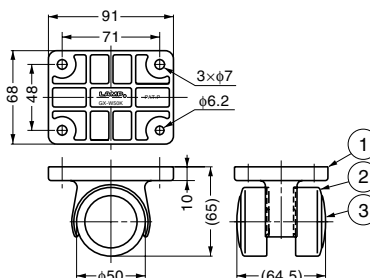

Features

- Thanks to the light weight aluminium body, the caster is strong and smart looking.
- Twin wheel caster with excellent stability.
- Use in combination with GX-W50K (Non-swivel type) for easy handling.

No.	Part Name	Material	Finish/Colour
①	Body	Aluminium Alloy	Polished
②	Wheel	Polyacetal (POM)	Black
③	Cover	Polyamide (PA)	Black

Item Code	Item Name	Load Capacity N	Load Capacity kgf	Weight	Box	Carton
200-130-032	GX-W50K	1960 N	200 kgf	328 g	2 pcs	48 pcs