

TWIN WHEEL CASTER (PLATE TYPE)

GX50P

GX50P
w/o BrakeGX50PS
w/ Brake

Features

- Thanks to the light weight aluminium body, the caster is strong and smart looking.
- Twin wheel caster with excellent stability.

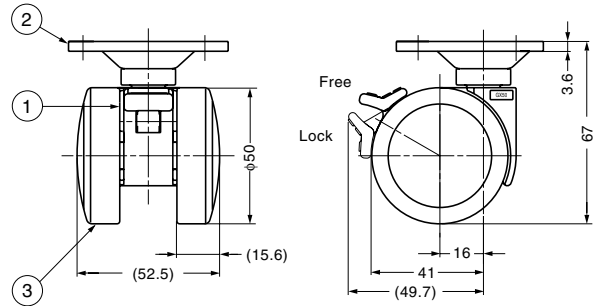
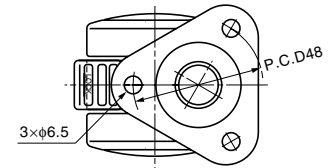

No.	Part Name	Material	Finish/Colour
①	Body	Aluminium Alloy	Polished
②	Plate	Steel	Yellow Zinc Chromate
③	Wheel	Polyamide (PA)	Black

Item Code	Item Name	Type	Load Capacity N	Load Capacity kgf	Weight	Box	Carton
200-133-173	GX50PS	With Brake	980 N	100 kgf	235 g	4 pcs	72 pcs
200-133-172	GX50P	Without Brake	980 N	100 kgf	230 g	4 pcs	72 pcs

TWIN WHEEL CASTER (THREADED BOLT TYPE)

GX50N12

GX50N12
w/o BrakeGX50N12S
w/ Brake

Features

- Thanks to the light weight aluminium body, the caster is strong and smart looking.
- Twin wheel caster with excellent stability.

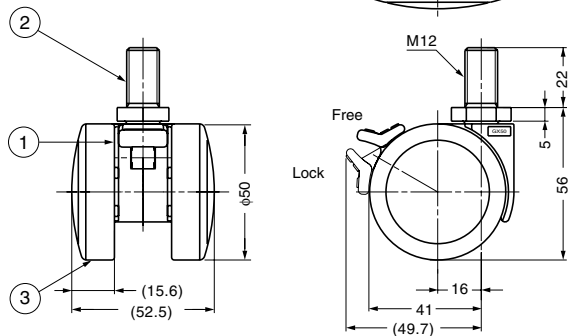
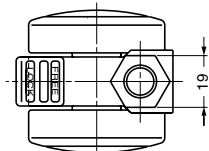

No.	Part Name	Material	Finish/Colour
①	Body	Aluminium Alloy	Polished
②	Threaded Bolt	Steel	Yellow Zinc Chromate
③	Wheel	Polyamide (PA)	Black

Item Code	Item Name	Type	Load Capacity N	Load Capacity kgf	Weight	Box	Carton
200-133-175	GX50N12S	With Brake	980 N	100 kgf	175 g	4 pcs	72 pcs
200-133-174	GX50N12	Without Brake	980 N	100 kgf	170 g	4 pcs	72 pcs