

TWIN WHEEL CASTER (PLATE TYPE)

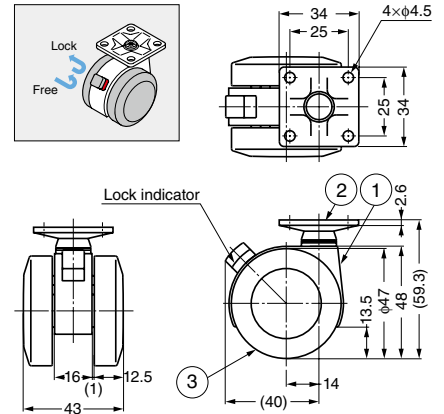

Features

Caster with high quality polyamide body.
Excellent durability, chemical / weather / wear resistance.



Item Code	Item Name	Type	Load Capacity N	Load Capacity kgf	Weight	Box	Carton
200-133-202	FP45PSR	With Brake	392 N	40 kgf	98 g	4 pcs	100 pcs
200-133-201	FP45PR	Without Brake	392 N	40 kgf	94 g	4 pcs	100 pcs

No.	Part Name	Material	Finish/Colour
①	Body	Polyamide (PA)	Black
②	Plate	Steel	Zinc Chromate
③	Wheel	Polyamide (PA)	Black

TWIN WHEEL CASTER (THREADED BOLT TYPE)

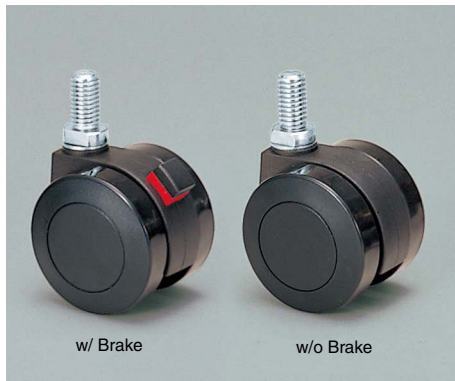

Features

Caster with high quality polyamide body.
Excellent durability, chemical / weather / wear resistance.

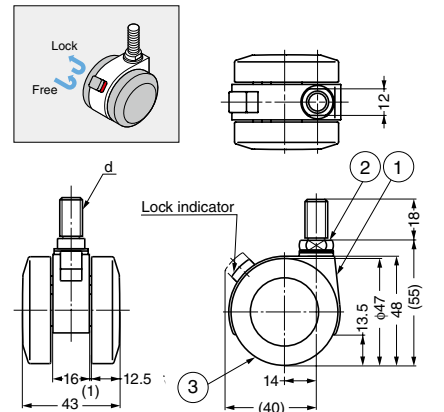

Item Code	Item Name	Type	d	Load Capacity N	Load Capacity kgf	Weight	Box	Carton
200-133-204	FP45N 3SR	With Brake	W3/8	392 N	40 kgf	84 g	4 pcs	100 pcs
200-133-203	FP45N 3R	Without Brake	W3/8	392 N	40 kgf	79 g	4 pcs	100 pcs
200-133-206	FP45N10SR	With Brake	M10	392 N	40 kgf	84 g	4 pcs	100 pcs
200-133-205	FP45N10R	Without Brake	M10	392 N	40 kgf	79 g	4 pcs	100 pcs

No.	Part Name	Material	Finish/Colour
①	Body	Polyamide (PA)	Black
②	Threaded Bolt	Steel	Zinc Chromate
③	Wheel	Polyamide (PA)	Black

TWIN WHEEL CASTER (INSERT BOLT TYPE)



Features

Caster with high quality polyamide body.
Excellent durability, chemical / weather / wear resistance.

Parts Included

Socket

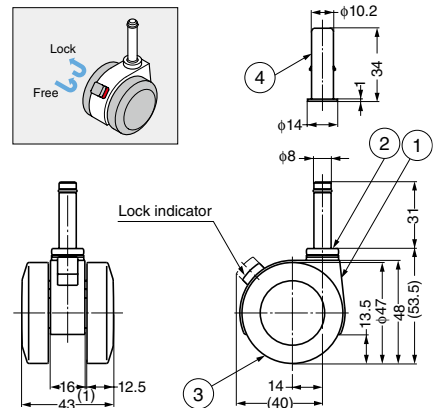
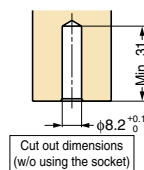

Item Code	Item Name	Type	Load Capacity N	Load Capacity kgf	Weight	Box	Carton
200-130-903	FP45SSR	With Brake	392 N	40 kgf	86 g	4 pcs	100 pcs
200-130-904	FP45SR	Without Brake	392 N	40 kgf	82 g	4 pcs	100 pcs

No.	Part Name	Material	Finish/Colour
①	Body	Polyamide (PA)	Black
②	Insert Bolt	Steel	Zinc Chromate
③	Wheel	Polyamide (PA)	Black
④	Socket	Steel	Zinc Chromate