

FOLDING BRACKET

LOAD CAPACITY 150~200 kgf

NSF SUS

EB

BRACKETS & SHELVING SYSTEM

FOLDING BRACKET / DAMPER FOR EB FOLDING BRACKET



Features

- Automatically locks when flap is in opened position.
- Press lever to release the lock.
- Bracket with hinge function in one unit.

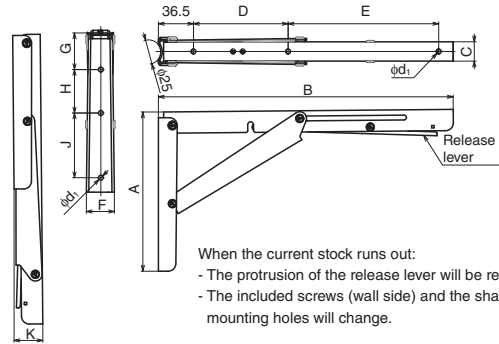

Item Name	A	B	C	D	E	F	G	H	J	K	d1
EB-200/EP	116	201	20	155	-	29	21	80	-	28.5	5.6
EB-303/EP	165	307		98	156	36	38	45	67		
EB-317/EP	171	318.5	24							30	6

CAD	Item Code	Old Item Code	Item Name	Old Item Name	Material	Finish	Load Capacity N	Load Capacity kgf	Weight (g)	Box (pcs)
	120-039-843	120-041-277	EB-200	EB-200/EP	Stainless Steel (SUS304)	Mirror	1716	175	332	20
	120-048-895	-	EB-200-BL	-	Stainless Steel (SUS304)	Black	1716	175	332	20
	120-039-844	120-018-226	EB-303	EB-303/EP	Stainless Steel (SUS304)	Mirror	1471	150	500	20
	120-048-896	-	EB-303-BL	-	Stainless Steel (SUS304)	Black	1471	150	500	20
	120-039-845	120-041-278	EB-317	EB-317/EP	Stainless Steel (SUS304)	Mirror	1961	200	750	20
	120-048-897	-	EB-317-BL	-	Stainless Steel (SUS304)	Black	1961	200	750	20

*The item names have been changed. The new version will come with an end cap and back plate.

DAMPER FOR EB FOLDING BRACKET



EBD

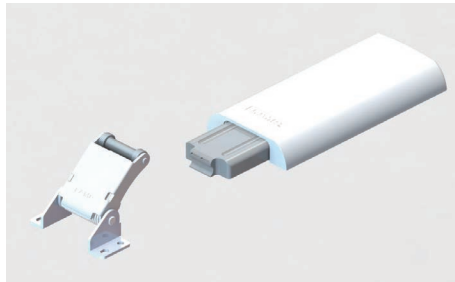

Application Example

Features

- Designed for use in combination with EB folding bracket.
- Lapcon damper mechanism prevents shelf from slamming when released.
- Installation position is easy to determine with supplied template.

Remarks

- Make sure to have sufficient in installation place strength.
- Please completely close shelf board with hands.

Parts Included

- Binding head tapping screw 4x16
- Template

Sold Separately

Folding bracket EB

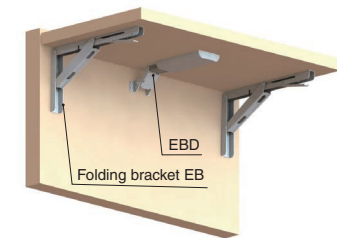

Shelf board Size Range

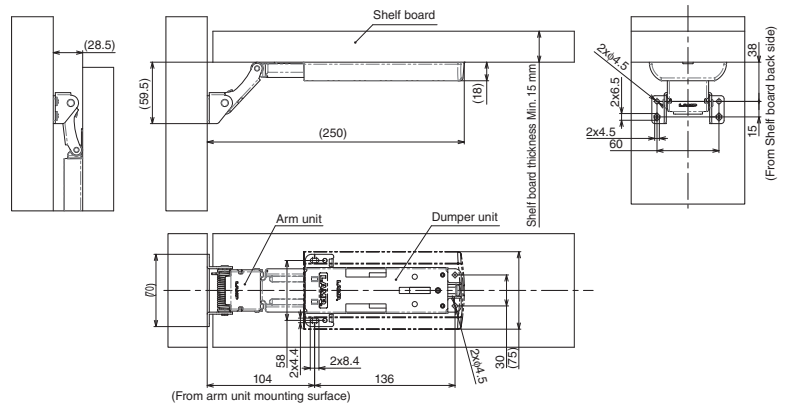
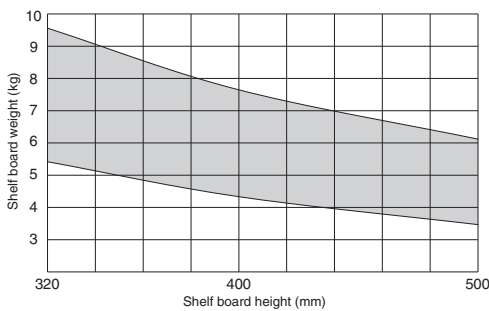

CAD	Item Code	Item Name	Material	Finish	Maximum Door Moment N-m	Maximum Door Moment kgf-cm	Flap thickness	Weight (g)	Box (pcs)	Carton (pcs)
	120-034-867	EBD	ABS/POM/Steel	Off-White/Zinc/Chrome	8.5 - 15	86.7 - 153.0	Min. 15	400	1	20