

PUSH LOCK FASTENER (MINI/BUTTON TYPE)

155F, 255F

PANEL MOUNTING SYSTEM

PUSH LOCK FASTENERS



155F



255F

- 2 piece fastener allows for fast and easy access with complete removal of panel.
 - Attach socket into outer panel/plug into removable panel.
 - Insert plug into socket and push to lock/unlock.
- Flush locked design prevents snagging.
- Fastens plastic or sheet metal panels.

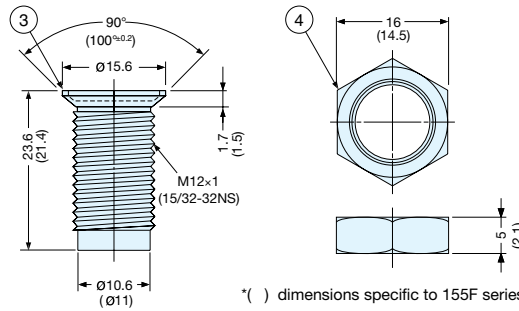
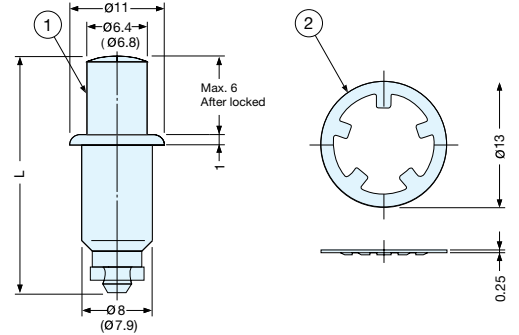

Preparation (Plug)

Board Thickness (P)=0.6~5.4 (0.8~4.8)

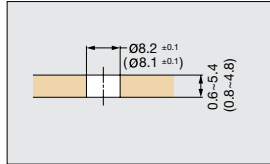

Board Thickness (P)=5.4~12.7 (More than 4.8)

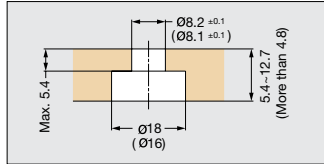

() dimensions specific to 155F series

Preparation (Socket)

Board Thickness=2.2~12

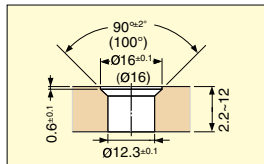

Board Thickness=0.6~2.2

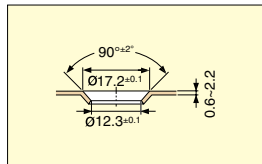

Board Thickness=0.6~9.7 (0.8~10)

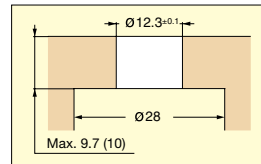
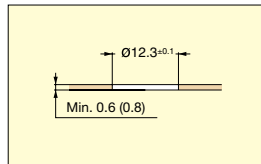

() dimensions specific to 155F series

Grip Dimensions

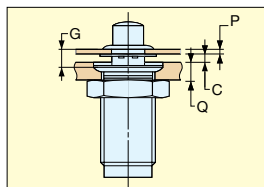

C=0~2.2 (0~2.5)
G=P+C+0.7
Q=2.2~12

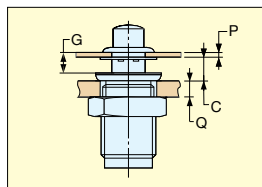

C=More than 2.3 (2.2)
G=P+C-1.4
Q=0.6~9.7

() dimensions specific to 155F series

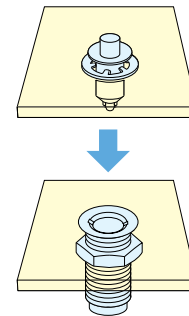

155F

No.	Part Name	Material	Finish
①	Plug	Zinc Alloy	Chrome
②	Ring	Steel	-
③	Socket	Zinc Alloy	Chromate
④	Nut	Steel	

255F

No.	Part Name	Material	Finish
①	Plug	Polyacetal	Black
②	Ring	Steel	
③	Socket	Polyacetal	
④	Nut		

Item No.	Grip Dimension G	Plug Dimension L	Retaining Force (kg)	Weight (g)
155F-01-1	1.2~2.8	23.5	15 (33 lbs)	6
155F-03-1	2.8~4.4	25.0		
155F-05-1	4.4~6.0	26.5		

Item No.	Grip Dimension G	Plug Dimension L	Retaining Force (kg)	Weight (g)
255F-01-3	1.2~2.8	23.5	15 (33 lbs)	6
255F-03-3	2.8~4.4	25.0		
255F-05-3	4.4~6.0	25.5		