

LAMP-AZ-GD310 STAINLESS STEEL DAMPENED FLAP LID SYSTEM

Installation instructions

Thank you for purchasing this stainless steel, dampened flap system. Please read these instructions carefully for a proper installation.



CAUTION If these cautions are not followed, it may result in injury or damage.



The AZ-GD310 is designed to function when installed vertically as shown below. Horizontal, slanted or upside down installation will result in improper function and may lead to injury.



To avoid any risk of accidental fall, ensure that the AZ-GD310 is securely fastened to its support.



Any attempt to dismantle, modify or use in any way other than that indicated below, may result in damage or injury.

Parts description

Description	Quantity
Flap lid body	1
Installation instruction	1
Warning sticker	1
Access hole cover caps	4

- Installation screws are not included (4 screws needed). Type and length of the screws should be decided by taking the type of support into consideration.

We recommend the use of Tapping ST3 screws.

Dimension drawing

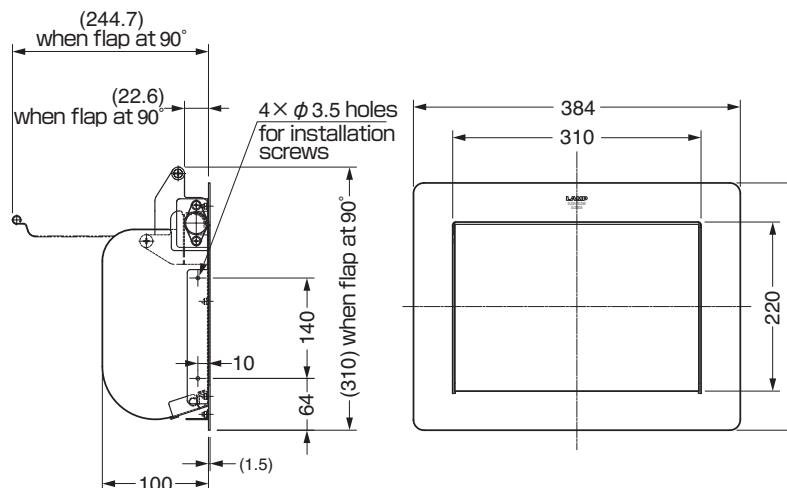

Cutout dimensions

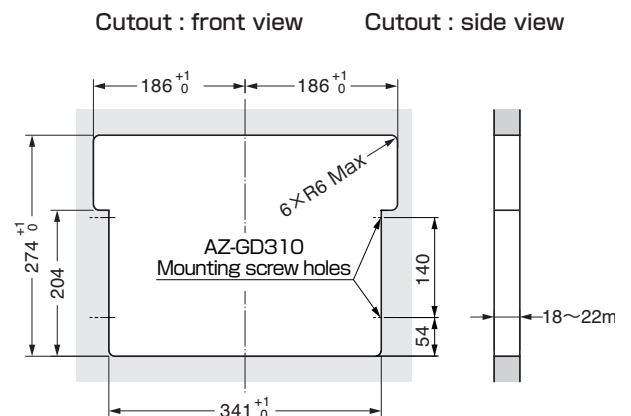

Installation procedure

1.

Insert the flap lid body in the cutout of the mounting surface.

! IMPORTANT:

- Make sure that the LAMP logo is at the top.
- Do not leave any gap between the flap lid body and the mounting surface

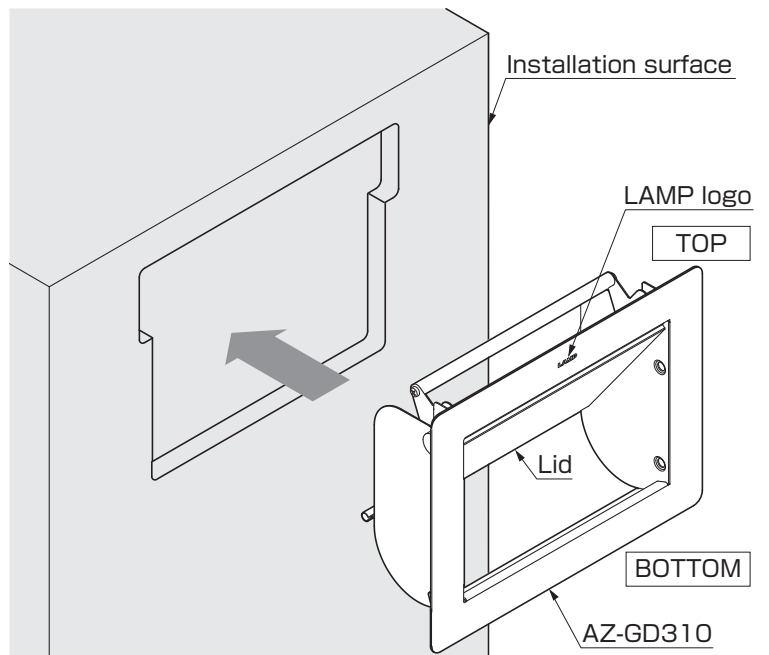

2.

Having opened the lid, insert the screws through the provided access screw holes (2 on each side) and fasten the flap lid body securely.

! IMPORTANT:

- Make sure that the final assembly is securely fastened.

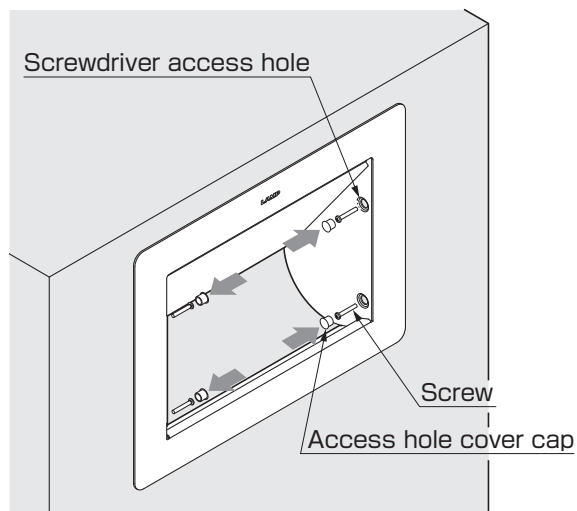

3.

Slowly open and close the lid completely a few times in order to make sure that there are no obstacles such as the bottom edge of the cutout or any item inside.

4.

Cover the screwdriver access holes with the caps provided.

5.

Past the warning sticker in a visible position to avoid any injury when using the AZ-GD310.

Hand or finger
may
get caught.

手ばさみに
ご注意ください



SUGATSUNE KOGYO CO.,LTD.
Phone: +81 3 3866 2260
F a x : +81 3 3866 4447
E-mail: export@sugatsune.co.jp
Website: www.sugatsune-intl.com

SUGATSUNE KOGYO (UK) LTD.
Phone: +44 118 9272 955
F a x : +44 118 9272 871
E-mail: sales@sugatsune.co.uk
Website: www.sugatsune.co.uk

SUGATSUNE AMERICA, INC.
Phone: +1 310 329 6373
F a x : +1 310 329 0819
E-mail: sales@sugatsune.com
Website: www.sugatsune.com

SUGATSUNE SHANGHAI CO., LTD.
Phone: +86 21 3632 1858
F a x : +86 21 3632 1868
E-mail: lamp@sugatsune.com.cn
Website: www.sugatsune.com.cn