

## DUAL BRAKE SYSTEM CASTER MX-125

### Design with Excellent User-friendliness

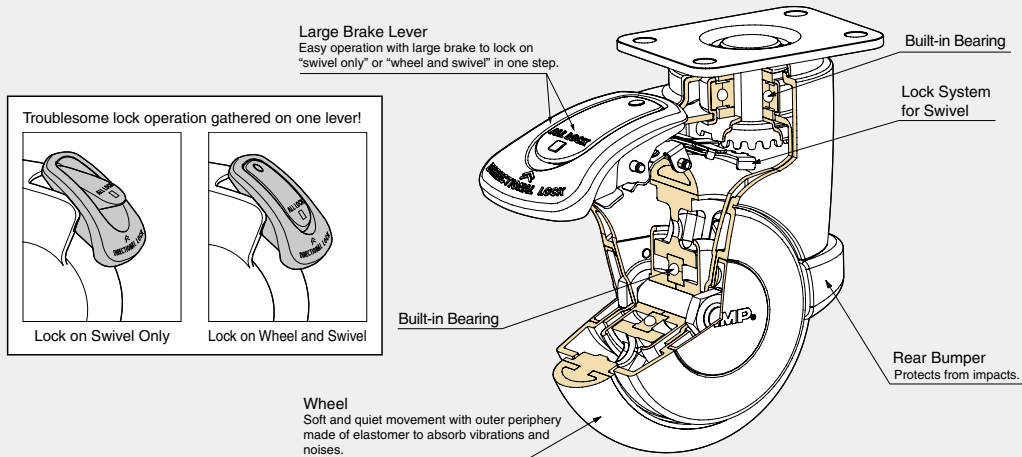

## DUAL BRAKE SYSTEM CASTER MX-125P Plate Type

**LOAD CAPACITY 1176 N**



- Ideal for frequent use such as equipment in hospitals and laboratories.
- Easy switching between "swivel" lock and "wheel+swivel" lock with one lock lever.
- Large lock lever for easy operation.
- Works as non-swivel type when swivel is locked.
- Ball bearing equipped in both swivel and wheel to provide maximum smooth movement.

#### [Others]

- Colour of logo, cover and lock lever can be changed.

#### [Remarks]

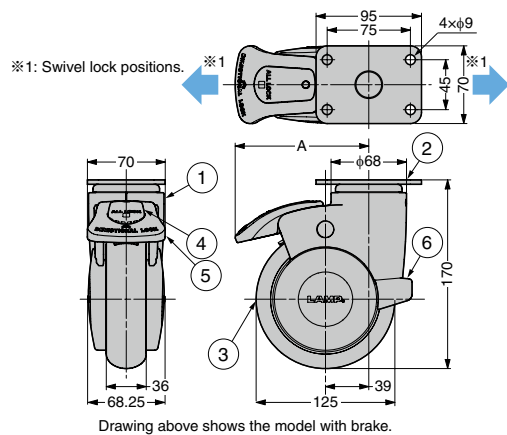
- To align swivel lock positions (see ※1 in the drawing below) for caster with brake, fix the caster with the plate longitudinal direction consistent with the moving direction when installing to a cart.



No.	Part Name	Material	Finish/Colour
①	Body	PP	Light Grey
②	Plate	Steel (SPCC)	Clear Zinc Chromate (Trivalent)
③	Wheel	PA/PUR	Dark Grey
④	Brake	PA	Dark Blue
⑤	Brake		Light Blue
⑥	Rear Bumper	PUR	Dark Grey

RoHS	CAD	Item Code	Item Name	Type	A	Load Capacity N/pc	Load Capacity kgf/pc	Weight (g)	Box (pcs)	Carton (pcs)
GD	BD	200-130-053	MX-125PS	With Brake	120.5	1176	120	1444	2	8
GD	BD	200-130-052	MX-125P	Without Brake	101.5			1357	2	8