

## DESIGN CASTER (PLATE TYPE)

PLN50P



## Features

Winner of the 2013 Good Design Award

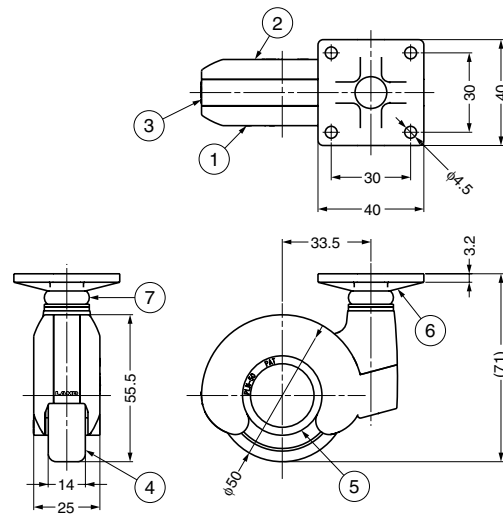

No.	Part Name	Material	Finish/Colour
①	Body (Right)	Zinc Alloy (ZDC)	As below.
②	Body (Left)		
③	Cover	Polyacetal (POM)	Dark Grey
④	Wheel	Polyamide (PA)	Black
⑤	Inner Ring		Dark Grey
⑥	Plate	Steel	Yellow Zinc Chromate
⑦	Mounting Plate	Stainless Steel (SUS304)	Mirror

Item Code	Item Name	Finish/Colour (Body)	Load Capacity N	Load Capacity kgf	Weight	Carton
200-022-220	PLN50PBL	Paint/Black	785 N	80 kgf	251 g	28 pcs
200-022-221	PLN50PCR	Chrome	785 N	80 kgf	251 g	28 pcs

## DESIGN CASTER (THREADED BOLT TYPE)

PLN50N



## Features

Winner of the 2013 Good Design Award

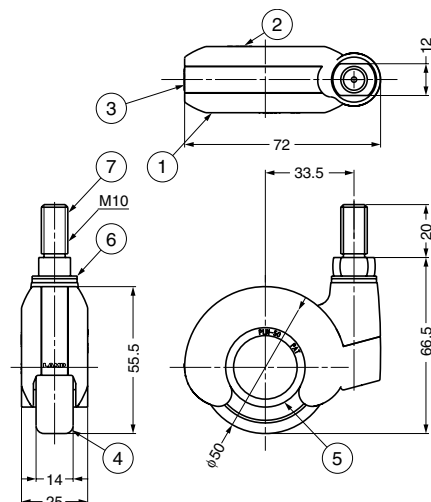

No.	Part Name	Material	Finish/Colour
①	Body (Right)	Zinc Alloy (ZDC)	As below.
②	Body (Left)		
③	Cover	Polyacetal (POM)	Dark Grey
④	Wheel	Polyamide (PA)	Black
⑤	Inner Ring		Dark Grey
⑥	Mounting Plate	Stainless Steel (SUS304)	Mirror
⑦	Threaded Bolt	Steel (SWCH)	Yellow Zinc Chromate

Item Code	Item Name	Finish/Colour (Body)	Load Capacity N	Load Capacity kgf	Weight	Carton
200-022-218	PLN50N10BL	Paint/Black	785 N	80 kgf	220 g	40 pcs
200-022-219	PLN50N10CR	Chrome	785 N	80 kgf	220 g	40 pcs