

Bodenelemente *Floor Elements*

Stellfüße *Leveling Feet*

Feste Stellfüße *Pivot Feet*



TELLER FÜR FESTE STELLFÜßE

BASE FOR PIVOT FEET

<p>Ausführung Zinkdruckguss, mit Anschraubbohrungen</p> <p>Beschreibung fester, nivellierbarer Stellfuß zur Befestigung am Boden</p> <p>Material Zinkdruckguss</p> <p>Liefereinheit 10 Stück</p> <p>Extras weitere Oberflächen, weitere Größen, weitere Farben, angeschraubte oder geklebte Anti-Slip-Platte auf Anfrage; als montierter Stellfuß auf Anfrage</p> <p>Hinweis passende Gewindestange siehe Seite 56, passende Mutter siehe Seite 80 f., passende Anti-Slip Platte siehe Seite 60</p>	<p>Model Zinc die-cast, with bolt-down holes</p> <p>Description A leveling foot which can be fixed to the floor</p> <p>Material Zinc die-cast</p> <p>Pack Quantity 10 pieces</p> <p>Specials other surfaces, other sizes, other colors, bolt-on or glued anti-slip plate on request; as factory assembled leveling foot on request</p> <p>Tip Compatible threaded rod see page 56, Compatible nut see page 80 et sq., Compatible anti-slip plate page 60</p>
-----------------------------------------------------------------------------------------------------------------------------------------------------------------------------------------------------------------------------------------------------------------------------------------------------------------------------------------------------------------------------------------------------------------------------------------------------------------------------------------------------------------------------------------------	--------------------------------------------------------------------------------------------------------------------------------------------------------------------------------------------------------------------------------------------------------------------------------------------------------------------------------------------------------------------------------------------------------------------------------------------------------------------------------------------------------

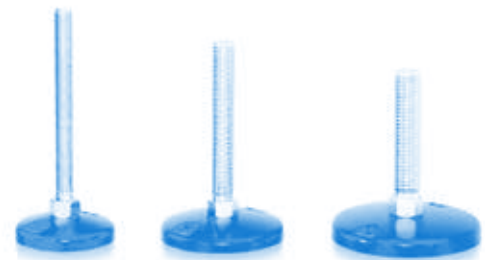
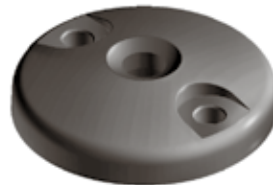
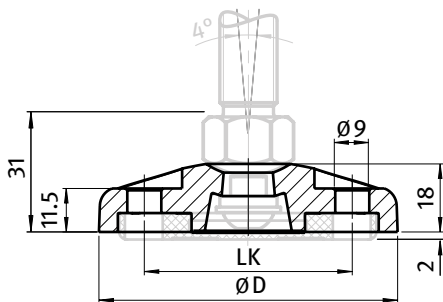

Teller Base	Teller für feste Stellfüße Base for Pivot Feet	D [mm]	LK [mm]	Tragkraft [kg] Max. Load [kg]	Gewicht [g] Weight [g]	Teil-Nr. Part #
60	ohne Anti-Slip-Platte Without anti-slip plate	59	40	3000	157.0	098A060ZBS
80	ohne Anti-Slip-Platte Without anti-slip plate	79	55	3500	256.0	098A080ZBS
100	ohne Anti-Slip-Platte Without anti-slip plate	99	74	3500	277.0	098A100ZBS
120	ohne Anti-Slip-Platte Without anti-slip plate	119	94	3500	580.0	098A120ZBS
60	mit Anti-Slip-Platte With anti-slip plate	59	40	3000	169.0	098A060ZBSG
80	mit Anti-Slip-Platte With anti-slip plate	79	55	3500	279.0	098A080ZBSG
100	mit Anti-Slip-Platte With anti-slip plate	99	74	3500	314.0	098A100ZBSG
120	mit Anti-Slip-Platte With anti-slip plate	119	94	3500	640.0	098A120ZBSG

