

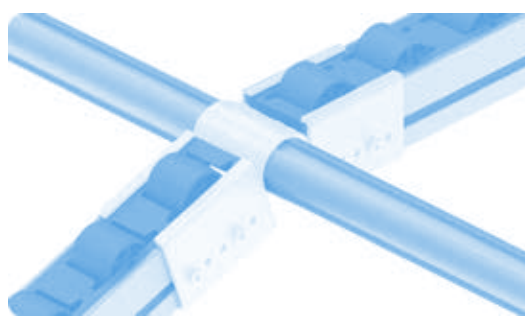

VARIABLE HALTER AL D28

VARIABLE HOLDING BRACKET AL D28

<p>Ausführung für Rollenschienen AL</p> <p>Beschreibung für Rollschienenübergang mit wechselndem Gefälle, zum Einhängen von Rollschienen AL mit variablem Neigungswinkel in ein Rundrohrprofil mit Außendurchmesser Ø 28 mm, verhindert das Herausrutschen von Einsätzen</p> <p>Material Stahl</p> <p>Oberfläche verzinkt</p> <p>Montageset 1 5 Bohrschrauben DIN 7504 Form N - 3,9 x 16</p> <p>Montageset 2 6 Bohrschrauben DIN 7504 Form N - 3,9 x 16</p> <p>Liefereinheit 10 Stück</p> <p>Extras weitere Oberflächen, weitere Farben auf Anfrage</p>	<p>Model For roller tracks AL</p> <p>Description Transition between roller track profiles with varying inclination, to mount roller track profiles AL at different angles to tubular frame profiles with Ø 28 mm outer diameter, preventig inserts from slipping out</p> <p>Material Steel</p> <p>Surface Zinc plated</p> <p>Assembly Set 1 5 self-drilling screws DIN 7504 Form N - 3.9 x 16</p> <p>Assembly Set 2 6 self-drilling screws DIN 7504 Form N - 3.9 x 16</p> <p>Pack Quantity 10 pieces</p> <p>Specials Other surfaces, other colors on request</p>
---	--

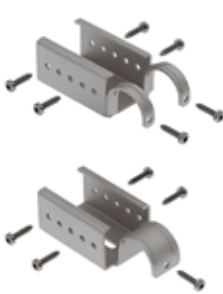
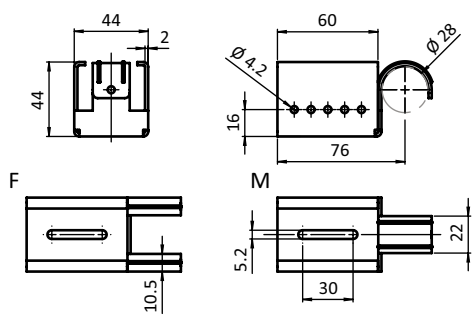

Variabler Halter AL D28 Variable Holding Bracket AL D28		Gewicht [g] Weight [g]	Teil-Nr. Part #
Typ M		144.0	062AYMD28M
Typ F		142.0	062AYFD28M
Typ M inkl. Montageset 1 <i>Type M with assembly set 1</i>		154.0	062AYMD28MS01
Typ F inkl. Montageset 2 <i>Type F with assembly set 2</i>		154.0	062AYFD28MS01

