

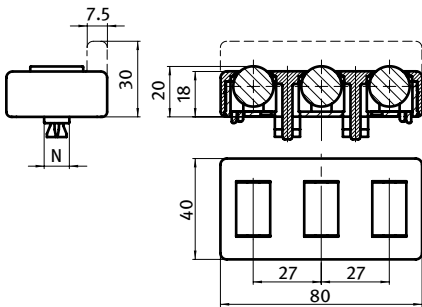

ROLLENELEMENT, CLIP-FIX

ROLLER ELEMENT, CLIP-FIX

Ausführung	Nut 8, 10	Model	Slot 8, 10
Beschreibung	zur Herstellung von Rollenbahnen in beliebiger Breite und Länge; schnelle, werkzeuglose Montage durch das Clip-Fix-System	Description	For manufacturing roller conveyors in any width and length; clip-fix system provides for quick assembly without any need for tools
Material	Gehäuse: Kunststoff PA, glaskugelverstärkt Rollen: Kunststoff POM	Material	Casing: Plastic PA, glass ball reinforced Rollers: Plastic POM
Farbe	schwarz	Color	Black
Befestigung	durch einfaches Eindrücken in die Nut, rastet sicher ein	Fastening	Secure fastening through simply inserting into slot
Liefereinheit	10 Stück	Pack Quantity	10 pieces



Rollenelement, Clip-Fix Roller Element, Clip-Fix	N	Gewicht [g] Weight [g]	Teil-Nr. Part #
ohne Seitenführung <i>Without lateral guide</i>	8-10	43.3	09309301
mit Seitenführung <i>With lateral guide</i>	8-10	48.0	09309303

