

Gleiter und Rollen *Sliders and Rollers*

Profilgleiter *Profile Sliders*

Profilgleiter ZN *Profile Sliders ZN*



PROFILGLEITER ZN 40 × 80 MIT EXZENTERHEBEL (SET) PROFILE SLIDER ZN 40 × 80 WITH CAM LEVER (SET)

<p>Ausführung Nut 8</p> <p>Beschreibung zur gleitenden Führung von Profilen mit Nut 8; zusätzliche Klemmung des Schlittens erhöht die Einsatzmöglichkeiten, z. B. als schnell verstellbarer Endanschlag; mit beiliegenden Sechskantmuttern M6 zur Befestigung von Anbauelementen</p> <p>Material Gleitschlitten: Zinkdruckguss Gleitschuh: Kunststoff POM Befestigung: Stahl Exzenterhebel: Kunststoff, glasfaserverstärkt Exzenterhebel-Mechanik: Stahl</p> <p>Farbe Gleitschuh: natur Exzenterhebel: schwarz</p> <p>Set 1 Gleitschlitten, 2 Gleitschuhe, 1 Exzenterhebel mit Aussengewinde M6 × 55*, 1 Sonder-Nutenstein - Nut 8 - M6, 2 Sechskantmuttern DIN 439 B - M6</p> <p>Liefereinheit 10 Stück</p> <p>Hinweis * Verwendung des Exzenterhebels M6: Profil 40 mm + Profil 40 mm, Gewindelänge: 55 mm Ablängen des Exzenterhebels M6, z.B.: Profil 40 mm + Profil 20 mm, Gewinde ablängen auf: 35 mm Profil 40 mm + Flächenelement 10 mm, Gewinde ablängen auf: 25 mm</p>	<p>Model Slot 8</p> <p>Description To guide slidingly profiles with slot 8, the additional clamping feature for the slide carriage extends the range of applications, e.g as quickly adjustable end stop; including hexagon nuts M6 for the attachment of additional components</p> <p>Material Sliding carriage: Zinc die-cast Slide shoe: Plastic POM Fixation: Steel Cam lever handle: Plastic, glass fiber reinforced Cam lever mechanics: Steel</p> <p>Color Slide shoe: Natural Cam lever handle: Black</p> <p>Set 1 sliding carriage, 2 slide shoes, 1 cam lever with external thread M6 × 55*, 1 special T-slot nut - slot 8 - M6, 2 hexagon nuts DIN 439 B - M6</p> <p>Pack Quantity 10 pieces</p> <p>Tip * Use of the M6 cam lever: 40 mm profile + 40 mm profile, thread length: 55 mm Cut to length of the M6 cam lever, e.g.: 40 mm profile + 20 mm profile, cut thread length to: 35 mm 40 mm profile + 10 mm panel, cut thread length to: 25 mm</p>
---	---

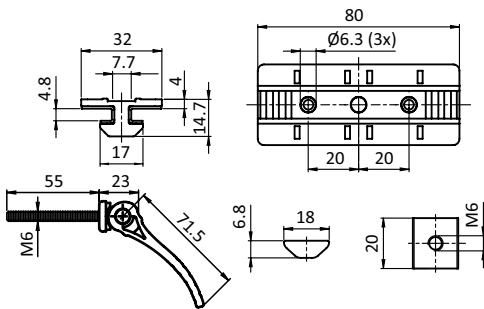

Profilgleiter ZN 40 × 80 (Set)
Profile Slider ZN 40 × 80 (Set)

mit Exzenterhebel <i>Witch cam lever</i>	Gewicht [g] Weight [g]	Profil Profile	Teil-Nr. Part #
	127.0	I	093PS0840S02