

Scharniere Hinges

Aluminiumdruckgusscharniere Aluminum Die-cast Hinges

Kombischarniere Combi Hinges



**ALUDRUCKGUSS-KOMBISCHARNIER 45**

**ALUMINUM DIE-CAST COMBI HINGE 45**

<b>Ausführung</b>	nicht aushängbar	<b>Model</b>	Non-detachable
<b>Beschreibung</b>	für Flächenelemente und Aluminiumprofile, pro Scharnierflügel je ein Steckplatz für Zentrierbolzen, Scharnierachse in Buchsensystem gelagert	<b>Description</b>	To hinge panels or aluminum profiles, each wing with a hole for centering bolts, with bearing system for axle
<b>Material</b>	Flügel: Aluminiumdruckguss Achse: Edelstahl Buchsen: PTFE Zentrierbolzen (optional): Kunststoff PA, glasfaserverstärkt	<b>Material</b>	Wings: Die-cast aluminum Axle: Stainless steel Bearings: PTFE Centering bolts (optional): Plastic PA, glass fiber reinforced
<b>Farbe</b>	Zentrierbolzen (optional): schwarz	<b>Color</b>	Centering bolts (optional): Black
<b>Befestigung</b>	vorderseitig mit Senkschrauben M6	<b>Fastening</b>	From the front, using M6 countersunk screws
<b>Liefereinheit</b>	10 Stück	<b>Pack Quantity</b>	10 pieces

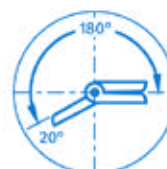
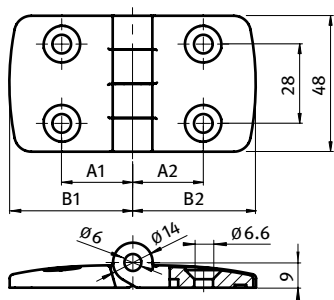

Kombischarnier Combi Hinge	A1 [mm]	A2 [mm]	B1 [mm]	B2 [mm]	F <sub>Amax</sub> [N]	F <sub>Rmax</sub> [N]	Bezeichnung Description	Gewicht [g] Weight [g]	Teil-Nr. Part #
nicht aushängbar Non-detachable	25.0	25.0	43.5	43.5	250	400	45/45	73.0	095A4545FS20
	25.0	27.5	43.5	48.5	250	400	45/50	76.0	095A4550FS20
	25.0	32.5	43.5	57.5	100	400	45/60	81.0	095A4560FS20
Zentrierbolzen Centering bolt							Nut 5 Slot 5	1.0	095AN05
							Nut 6 Slot 6	1.0	095AN06
							Nut 8 Slot 8	1.0	095AN08
							Nut 10 Slot 10	1.0	095AN10
							Nut 12 Slot 12	1.0	095AN12
							Nut 14 Slot 14	1.0	095AN14

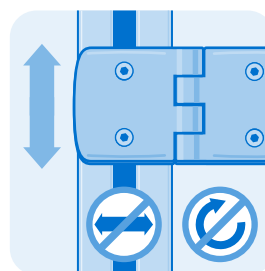
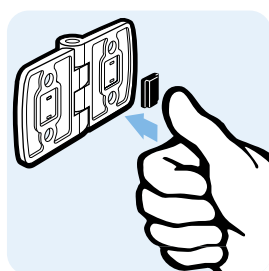

2