

REVISION HISTORY			
REV	DATE	BY	DESCRIPTION
C	08AUG2019	RES/MJS	PRN: P2019-1038

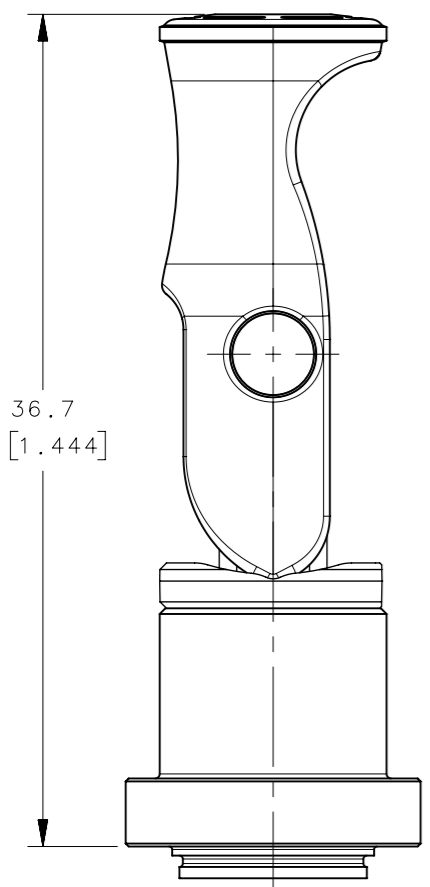

UNFASTENED

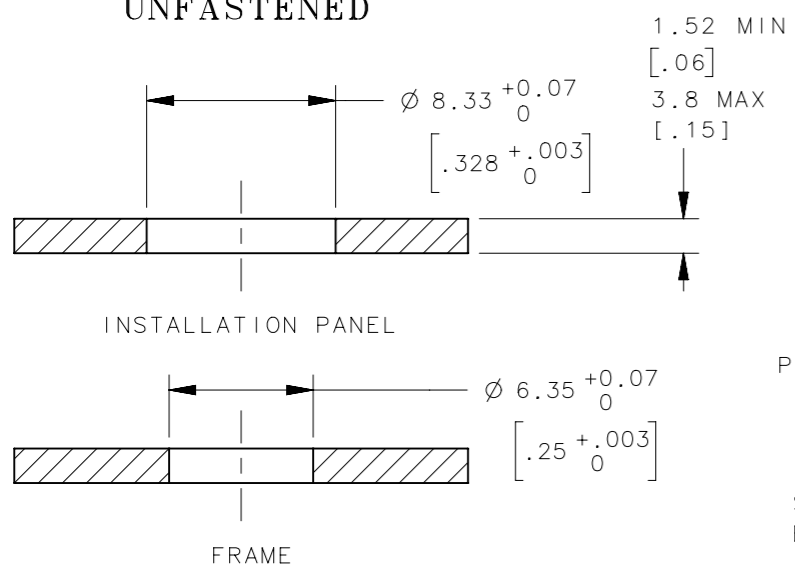

$\varnothing 10.5 \pm 0.1$
[.413 \pm .004]

INSTALLATION TOOL
SOUTHCO PART NUMBER
56-4-TOOL

38
[1.496]

$\varnothing (12.65)$
[.498]

PANEL
SOLID
BACK-UP

INSTALLATION
SEE NOTE C

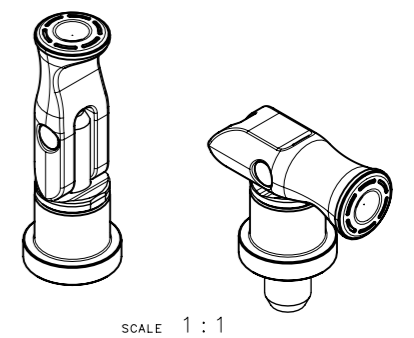
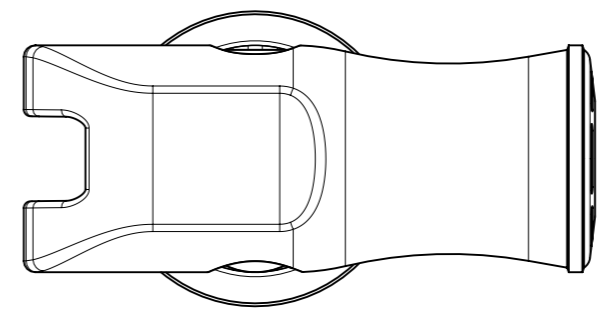

SCALE 1:1

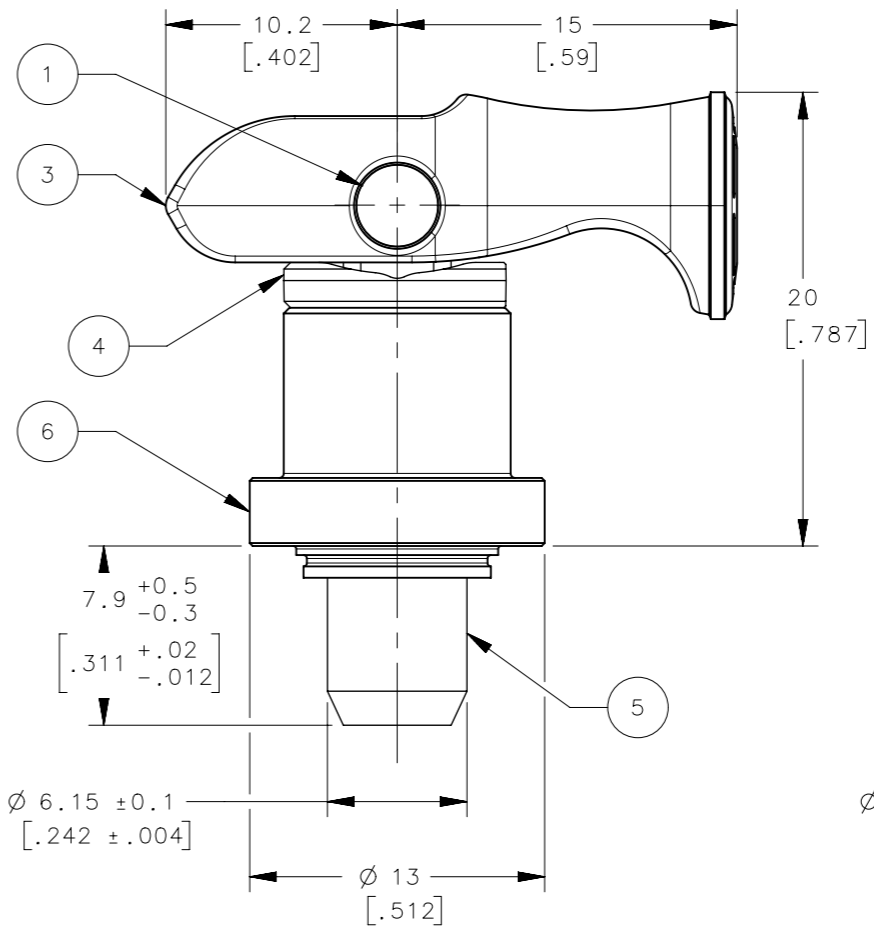

FASTENED

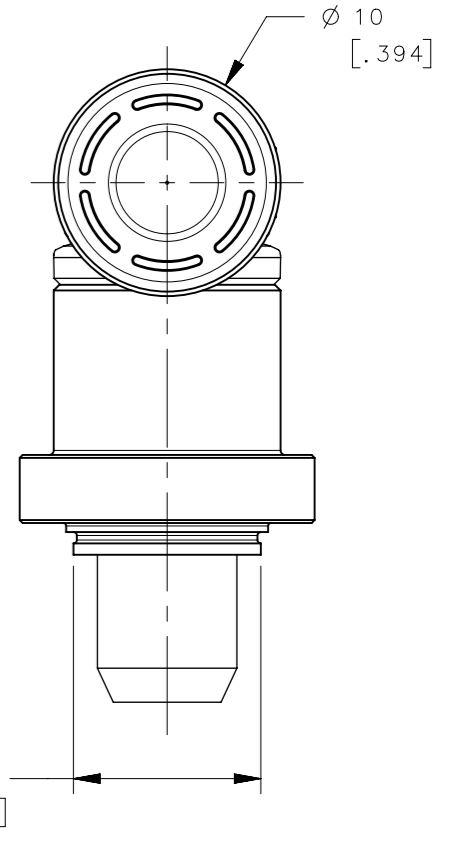

SEE NOTE B

NOTES:

- A. SURFACES ABOVE PANEL TO MEET CLASS D REQUIREMENTS OF SOUTHCO COSMETIC SPECIFICATION S-121
- B. EEE IN PART NUMBER DESIGNATES LEVER AND WASHER COLOR, SEE DRAWING J-47-0-3 FOR DETAILS. EEE = 000 FOR BLACK
- C. INSTALLATION:
 1. PREPARE HOLE IN PANEL.
 2. PLACE PLUNGER (IN UNFASTENED ORIENTATION) INTO HOLE.
 3. PROVIDE SOLID BACK-UP UNDER PANEL USING INSTALLATION TOOL PRESS FERRULE UNTIL COLLAR IS FIRMLY AGAINST PANEL.

56-461-EEE				
PART NUMBER				
6	1	FERRULE	STEEL	ZINC PLATE
5	1	STUD	STEEL	ZINC PLATE
4	1	WASHER	PC-ABS UL94 V0	SEE NOTE B
3	1	LEVER	NYLON 30% GF UL94 V0	SEE NOTE B
2	1	SPRING	STAINLESS STEEL	PASSIVATE
1	1	RIVET	STAINLESS STEEL	NATURAL
NO.	QTY	TYPE OF COMPONENT	MATERIAL	FINISH

CPB NUMBER 2018-0595	THIRD ANGLE PROJECTION
	MILLIMETERS [IN]
	TOLERANCES UNLESS OTHERWISE NOTED
	ALL DIMENSIONS WITHOUT TOLERANCES ARE FOR REFERENCE ONLY.
PROPRIETARY ITEM EXCEPT FOR USES EXPRESSLY GRANTED IN WRITING, INFORMATION DISCLOSED HEREON IS CONFIDENTIAL AND ALL RIGHTS, PATENT AND OTHERWISE, ARE RESERVED BY SOUTHCO, INC.	PER ASME Y14.5M-1994

southco[®]
CONNECT • CREATE • INNOVATE

DESCRIPTION
**QUICK ACCESS FASTENER
LEVER OPERATED PLUNGER; PRESS-IN**

SIZE A3	SYSTEM NX	DWG NO. J-56-461
DRAWN BY RES	DATE 18OCT2018	SCALE 3:1
		SHEET 1 OF 1