



# E5 Cam Latches

## Overview

### Modularity and simplicity in action

The *SOUTHCO*® E5 cam latch is a highly modular and easy to configure solution, suitable for a wide range of applications. By changing any of the three basic components (access style driver, latch body or cam) in either geometry or material, the E5 can be easily adjusted to suit most applications.

#### Product features

- Cost effective, easy to design and install
- Multiple material and access options to suit multiple needs
- Suitable to meet NEMA 4 / IP65 sealing standards
- Corrosion-resistant materials available
- Highly modular and configurable

#### ➤ Match material and finish options for style and functionality requirements

A variety of materials and finishes to complement your application.

Die-cast zinc latch bodies standard finishes:



Chrome plated



Black powder coated

Corrosion resistant materials available



316  
Stainless steel



Glass-filled  
nylon, black



304  
Stainless steel

#### ➤ Select one of these four styles to fit your access requirements

There are four basic E5 styles to meet specific door configuration and mounting requirements in terms of design, depth, surface protrusion and operation style.

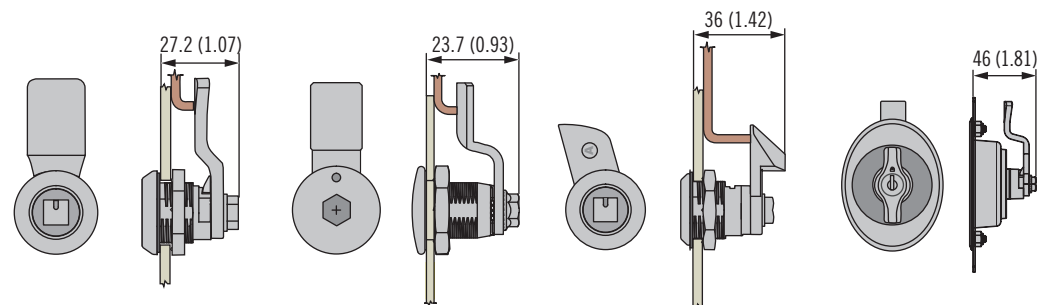

#### E5 Standard

Industry standard, highly modular and configurable options in a wide choice of materials, finishes and access styles. (See page 118)

#### E5 Low Profile

Stylish, low profile design. Tool and hand operated access styles in zinc alloy chrome plated or black powder coated. (See page 120)

#### E5 Push-to-Close

Standard E5 with the added functionality of a spring-loaded cam or actuator for single or multi-point operation. Provides quicker turn-to-open, push-to-close action. (See page 128)

#### E5 Flush Cup Wing Knob

Stylish oval cup design. Provides a clean, flush outer surface. Ideal for multi-point actuation of large doors in aesthetically pleasing applications. (See page 122)

Dimensions in millimeters (inch) unless otherwise stated



[www.southco.com](http://www.southco.com)

**southco**  
CONNECT · CREATE · INNOVATE

➔ Choose from a wide range of operating styles to fit application and industry requirements.

- ➔ Convenient hand-operated wing knob, T and L-handle styles for easy hand access
- ➔ Tool operated for restricted access, flush-mount or low-profile clearances, and industry-specific standards
- ➔ Key operated for added security

**Hand operable**

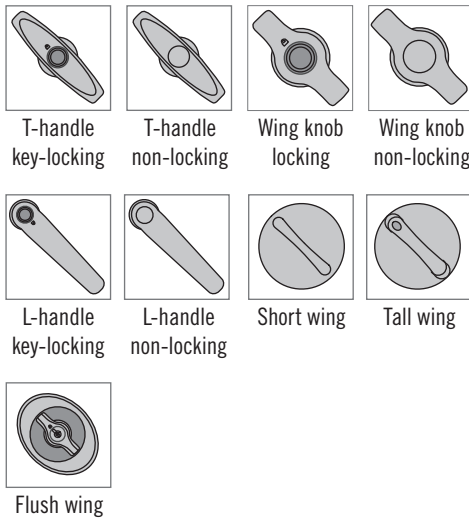

**Tool / key operable**

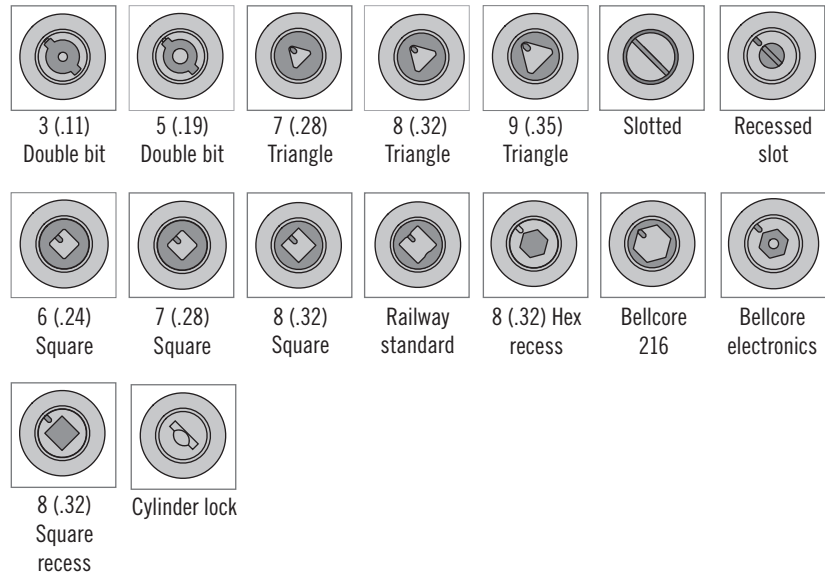

➔ Determine your grip options for a perfect fit

Total grip includes the dimensions of all elements in-between the mounting surface of the latch and the latch's contact surface on the frame - including door thickness, compressed seals and gaskets, accessories, frame offset, etc.

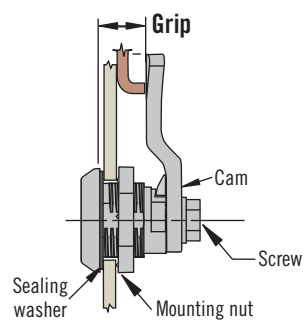

Selecting the right cam for the E5 is easy once the total grip is known. Southco provides a wide selection of standard cams in many grip increments, and special ones like hook and push-to-close cams. Standard cams provide vibration resistance and grip variation tolerance.

**Installation**

Some *SOUTHCO*® E5 latches are shipped latch and cam separately and some completely pre-assembled. See product pages for details.

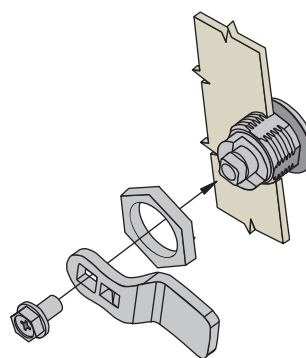

**E5 Standard**  
Latch and cam shipped separately.

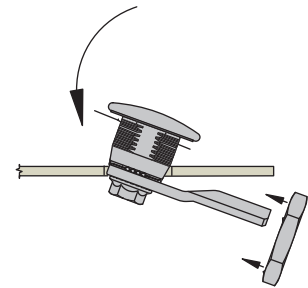

**E5 Low Profile**  
Latch and cam shipped pre-assembled.



# E5 Cam Latch

Stainless steel · Tool operated · Fixed grip

- Single hole install
- Latched / unlatched indicator
- EN 45545-3 E60 Compliant

### Material and Finish

Stainless steel, 304 or 316 grade

### Performance Details

Maximum static load:

304 Stainless steel 550 N (124 lbf)

316 Stainless steel 670 N (150 lbf)

### Sealing Notes

NEMA 4 / IP65 achieved using gasket supplied

### Installation Notes

Mounting nut:

Maximum tightening torque:

20 N·m (177 in·lbf)

Screw Maximum tightening torque

10 N·m (90 in·lbf)

### Keys and Accessories

See page 130

### Part Number Selection

See table

Order latch and cam separately

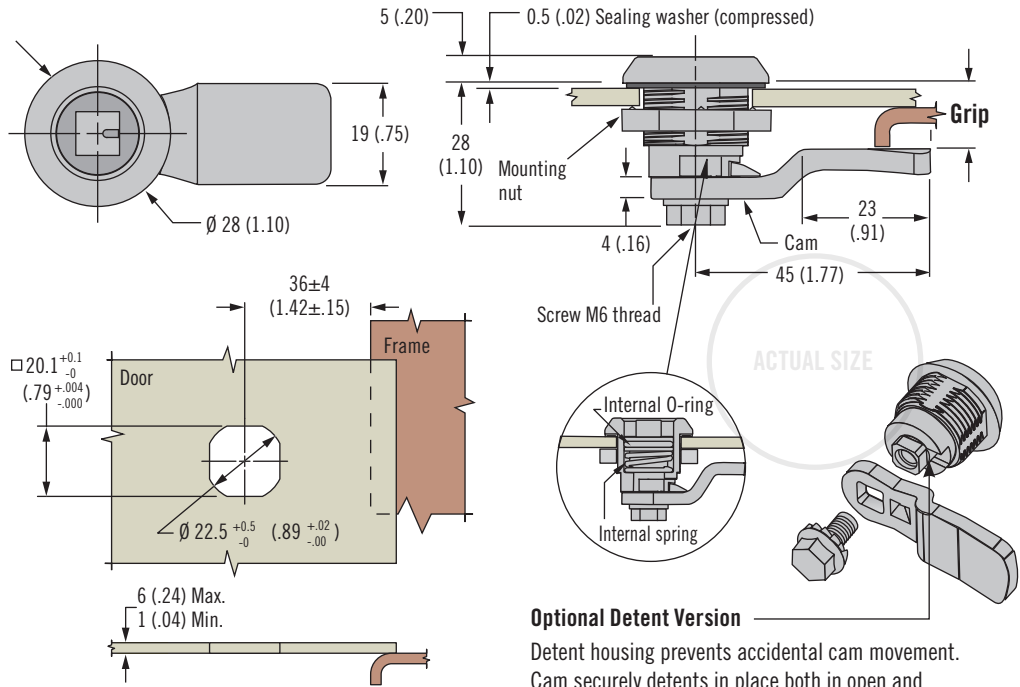

### H Head Styles

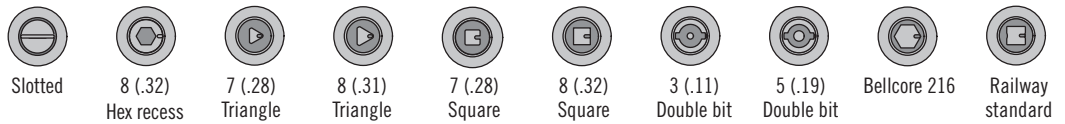

### Optional Detent Version

Detent housing prevents accidental cam movement. Cam securely detents in place both in open and closed positions.

**Latch Part Number (no cam)**

**E5 - B - H M - UU1**

**B Body**  
 6 Normal housing  
 32 Detented housing

**H Head style**  
 00 Slotted  
 01 8 (.32) Hex recess  
 02 7 (.28) Triangle  
 03 8 (.32) Triangle  
 04 7 (.28) Square  
 05 8 (.32) Square  
 06 3 (.11) Double bit  
 07 5 (.19) Double bit  
 13 Bellcore 216  
 22 Railway standard

**M Material**  
 24 304 Stainless steel  
 27 316 Stainless steel

Cam Part Number Table (order separately from latch)

Grip +2(.08) - 0 (.00)	Part Number		Grip +2(.08) - 0 (.00)	Part Number		Grip +2(.08) - 0 (.00)	Part Number		Grip +2(.08) - 0 (.00)	Part Number	
	304 Stainless steel	316 Stainless steel		304 Stainless steel	316 Stainless steel		304 Stainless steel	316 Stainless steel		304 Stainless steel	316 Stainless steel
4 (.16)	E5-8003	E5-9003	14 (.55)	E5-8008	E5-9008	24 (.94)	E5-8013	E5-9013	34 (1.34)	E5-8018	E5-9018
6 (.24)	E5-8004	E5-9004	16 (.63)	E5-8009	E5-9009	26 (1.02)	E5-8014	E5-9014	36 (1.42)	E5-8019	E5-9019
8 (.31)	E5-8005	E5-9005	18 (.71)	E5-8010	E5-9010	28 (1.10)	E5-8015	E5-9015	38 (1.50)	E5-8020	E5-9020
10 (.39)	E5-8006	E5-9006	20 (.79)	E5-8011	E5-9011	30 (1.18)	E5-8016	E5-9016	40 (1.57)	E5-8021	E5-9021
12 (.47)	E5-8007	E5-9007	22 (.87)	E5-8012	E5-9012	32 (1.25)	E5-8017	E5-9017	42 (1.65)	E5-8022	E5-9022



# E5 Cam Latch

Zinc · Tool operated · Adjustable grip



118A

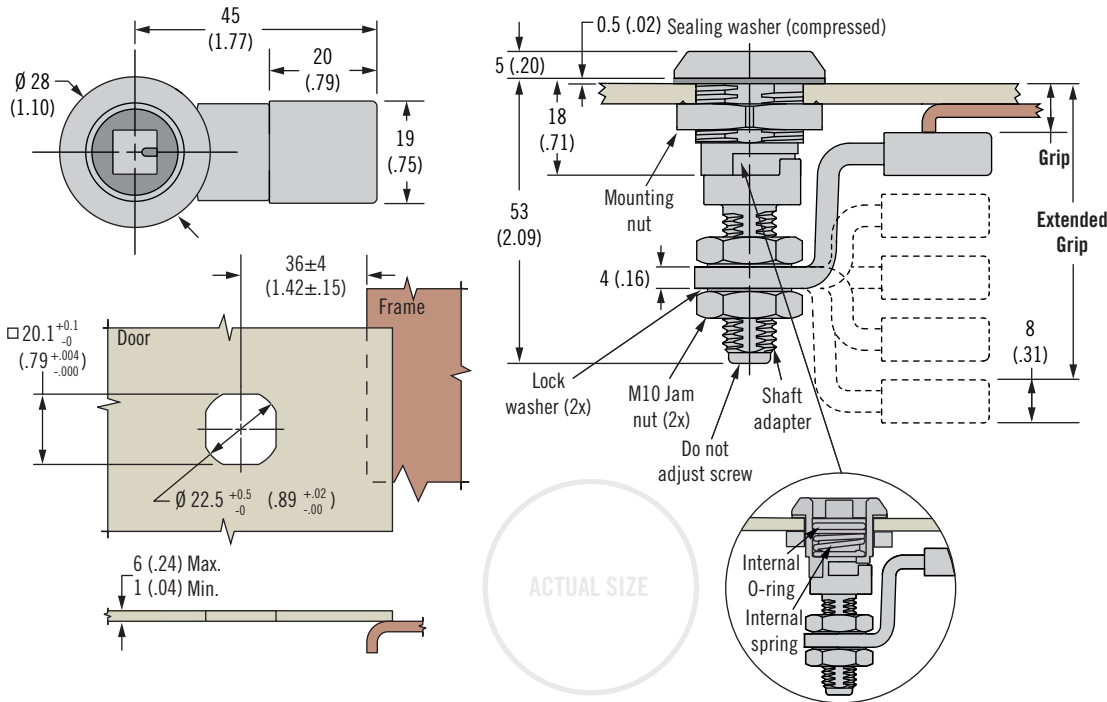

- Single hole install
- Latched / unlatched indicator
- Easy grip adjustment
- Tool operated for security

## Material and Finish

Zinc alloy, powder coated or chrome plated and steel, zinc plated

## Performance Details

Maximum static load: 330 N (74 lbf)

## Installation Notes

Position cam so latching function can be achieved comfortably by hand. Recommended tightening torque for mounting nut is 10 N·m (88 in·lbf) max, and jam nut is 7 N·m (62 in·lbf)

## Sealing Notes

NEMA 4 / IP65 achieved using gasket supplied

## Keys and Accessories

See page 130

## Part Number Selection

See table

Order latch and cam separately

## H Head Styles

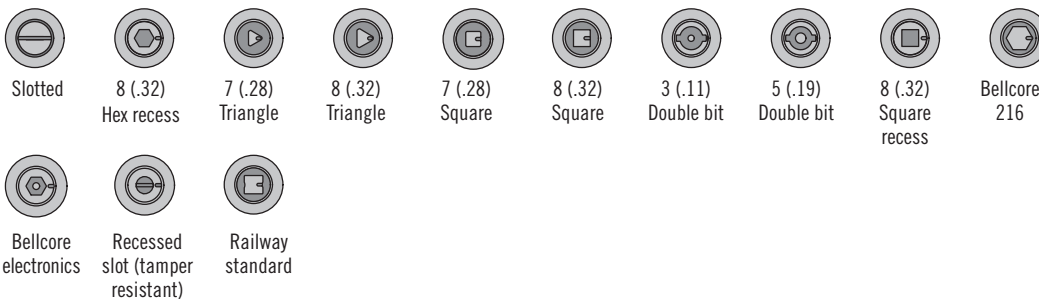

Latch Part Number (no cam)

**E5 - 6 - H F - 01**

## H Head style

- 00 Slotted
- 01 8 (.32) Hex recess
- 02 7 (.28) Triangle
- 03 8 (.32) Triangle
- 04 7 (.28) Square
- 05 8 (.32) Square
- 06 3 (.11) Double bit
- 07 5 (.19) Double bit
- 08 8 (.32) Square recess
- 13 Bellcore 216
- 19 Bellcore electronics
- 21 Recessed slot (tamper resistant)
- 22 Railway standard

## F Finish

- 2 Bright chrome
- 5 Black powder coated

Cam Part Number Table (order separately from latch)

Minimum Grip +2(.08) - 0 (.00)	Maximum Grip +2(.08) - 0 (.00)	Cam Type	Part Number
5 (.20)	16.5 (.65)	Deep Offset Cam, Forward	E5-4001
51 (2.01)	62.5 (2.46)	Deep Offset Cam, Reversed	
16.5 (.65)	28 (1.10)	Offset Cam, Forward	E5-4002
39.5 (1.56)	51 (2.01)	Offset Cam, Reversed	
28 (1.10)	39.5 (1.56)	Straight Cam	E5-4003

# E5 Cam Latch

Zinc · Tool operated · Fixed grip

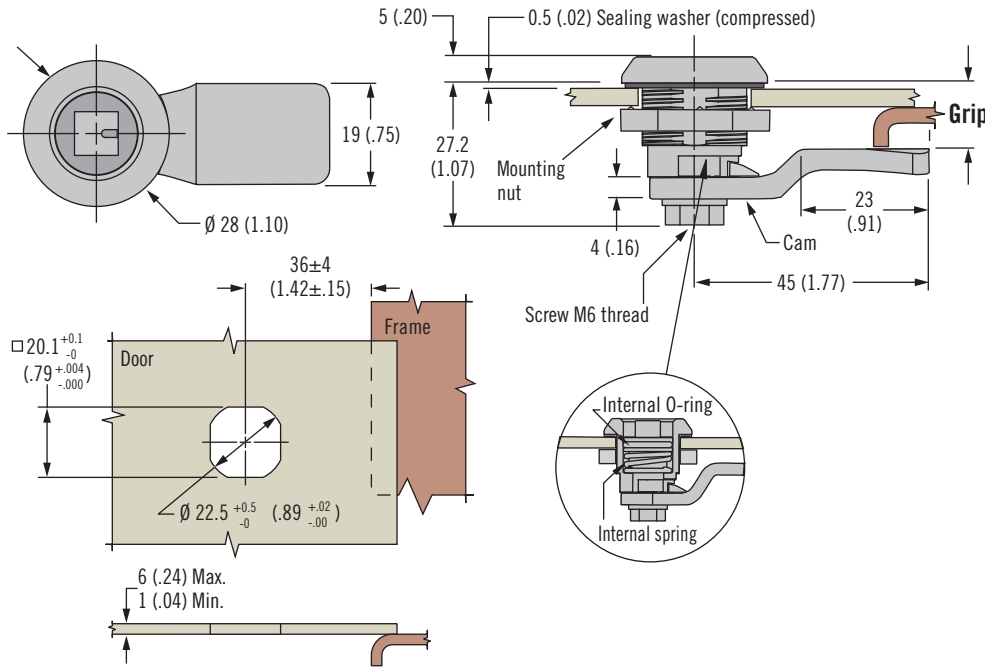

- Single hole install
- Latched / unlatched indicator
- EN 45545-3 E10 Compliant

### Material and Finish

Zinc alloy, powder coated or chrome plated and steel, zinc plated

### Performance Details

Maximum static load: 330 N (74 lbf)

### Installation Notes

Mounting nut:  
Maximum tightening torque:  
10 N·m (88 in·lbf)

Screw Maximum tightening torque:  
5 N·m (45 in·lbf)

### Sealing Notes

NEMA 4 / IP65 achieved using gasket supplied

### Keys and Accessories

See page 130

### Notes

Suitable for push-to-close action  
see page 128

### Part Number Selection

See table

Order latch and cam separately

### H Head Styles

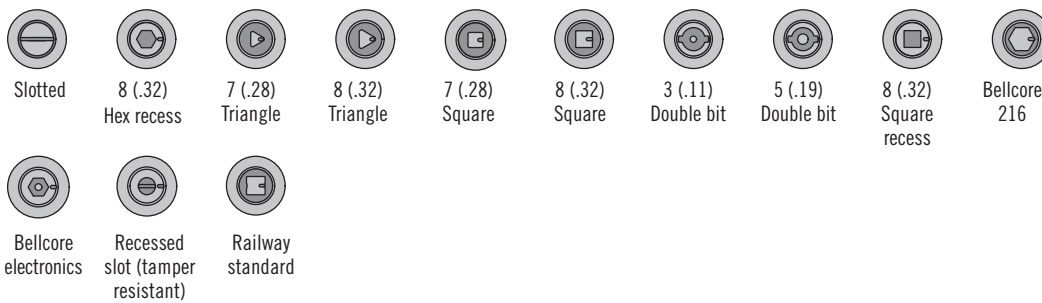

### Latch Part Number (no cam)

**E5 - 6 - H F - UU1**

### F Finish

- 2 Bright chrome
- 5 Black powder coated

### H Head style

- 00 Slotted
- 01 8 (.32) Hex recess
- 02 7 (.28) Triangle
- 03 8 (.32) Triangle
- 04 7 (.28) Square
- 05 8 (.32) Square
- 06 3 (.11) Double bit
- 07 5 (.19) Double bit
- 08 8 (.32) Square recess
- 13 Bellcore 216
- 19 Bellcore electronics
- 21 Recessed slot (tamper resistant)
- 22 Railway standard

Cam Part Number Table (order separately from latch)

Grip +2(.08) - 0 (.00)	Part Number	Grip +2(.08) - 0 (.00)	Part Number	Grip +2(.08) - 0 (.00)	Part Number	Grip +2(.08) - 0 (.00)	Part Number
4 (.16)	E5-6003	14 (.55)	E5-6008	24 (.94)	E5-6013	34 (1.34)	E5-6018
6 (.24)	E5-6004	16 (.63)	E5-6009	26 (1.02)	E5-6014	36 (1.42)	E5-6019
8 (.31)	E5-6005	18 (.71)	E5-6010	28 (1.10)	E5-6015	38 (1.50)	E5-6020
10 (.39)	E5-6006	20 (.79)	E5-6011	30 (1.18)	E5-6016	40 (1.57)	E5-6021
12 (.47)	E5-6007	22 (.87)	E5-6012	32 (1.25)	E5-6017	42 (1.65)	E5-6022



# E5 Cam Latch

Zinc · Shutter · Tool operated · Fixed grip

- Single hole install
- Latched / unlatched detent
- Vibration resistant
- EN 61373 Compliant

### Material and Finish

Zinc alloy, powder coated or chrome plated and steel, zinc plated

### Performance Details

Maximum static load: 330 N (74 lbf)

### Installation Notes

Mounting nut maximum tightening torque: 10 N·m (88 in·lbf)

Screw Maximum tightening torque: 5 N·m (45 in·lbf)

### Sealing Notes

NEMA 4 / IP65 achieved using gasket supplied



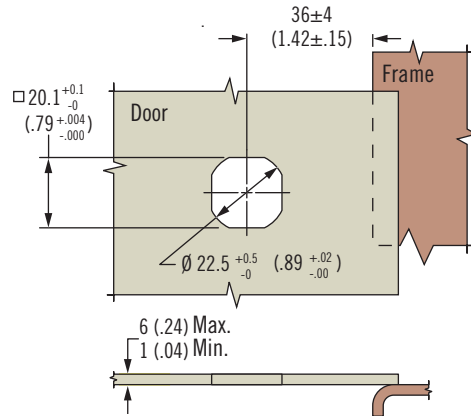
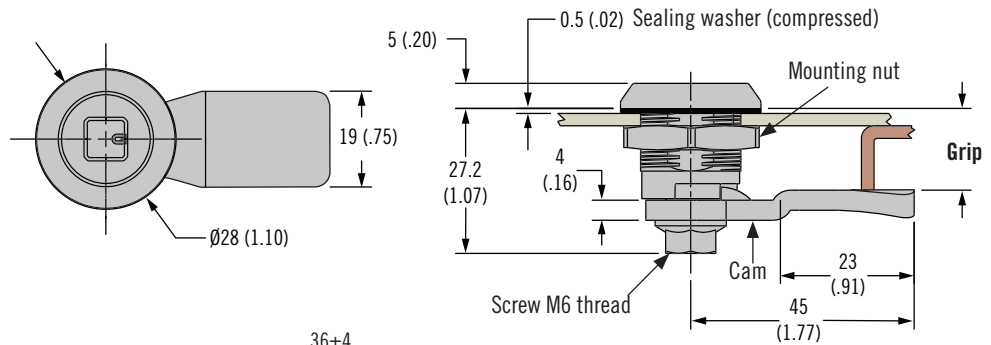

### Keys and Accessories

See page 130



Insert key to depress shutter and rotate cam

### H Head Styles

-   
 7 (.28)  
 Triangle
-   
 8 (.32)  
 Triangle
-   
 7 (.28)  
 Square
-   
 8 (.32)  
 Square
-   
 Bellcore  
 216

### Part Number Selection

See table

Order latch and cam separately

Latch Part Number (no cam)

**E5 - 8 - H F - UU1**

- F** Finish
- 2 Bright chrome
  - 5 Black powder coated

- H** Head style
- 02 7 (.28) Triangle
  - 03 8 (.32) Triangle
  - 04 7 (.28) Square
  - 05 8 (.32) Square
  - 13 Bellcore 216

Cam Part Number Table (order separately from latch)							
Grip	Part Number	Grip	Part Number	Grip	Part Number	Grip	Part Number
4 (.16)	E5-6003	14 (.55)	E5-6008	24 (.94)	E5-6013	34 (1.34)	E5-6018
6 (.24)	E5-6004	16 (.63)	E5-6009	26 (1.02)	E5-6014	36 (1.42)	E5-6019
8 (.31)	E5-6005	18 (.71)	E5-6010	28 (1.10)	E5-6015	38 (1.50)	E5-6020
10 (.39)	E5-6006	20 (.79)	E5-6011	30 (1.18)	E5-6016	40 (1.57)	E5-6021
12 (.47)	E5-6007	22 (.87)	E5-6012	32 (1.25)	E5-6017	42 (1.65)	E5-6022





# E5 Cam Latch Low Profile

Zinc · Tool or hand operated · Fixed grip

- Single hole install
- Latched / unlatched indicator
- Shipped fully assembled
- EN 45545-3 E10 Compliant

### Material and Finish

Zinc alloy, powder coated or chrome plated and steel, zinc plated

### Performance Details

Maximum static load: 330 N (74 lbf)

### Installation Notes

Mounting nut  
Maximum tightening torque:  
10 N·m (88 in·lbf)

### Keys and Accessories

See page 130

### Part Number Selection

See table

Latch is shipped fully assembled

For door thicknesses

1 - 6 (.039 - .236) grip must exceed door thickness by 4 (.157) for assembled installation

When sealing option is selected, add 0.4 (.02) to grip calculation to accommodate sealing washer

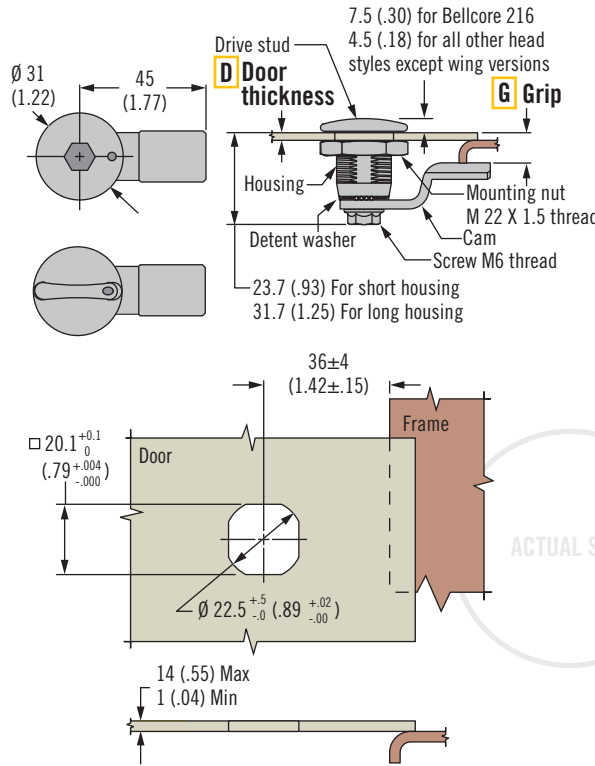

### H Head Styles

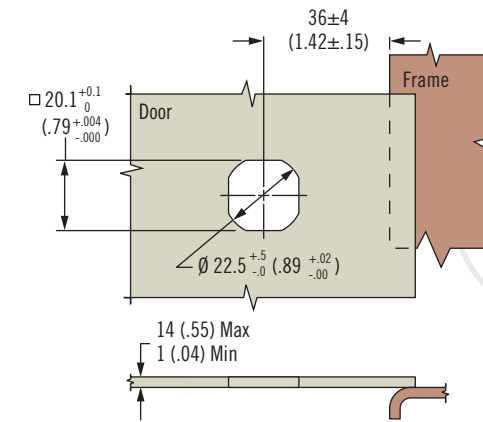
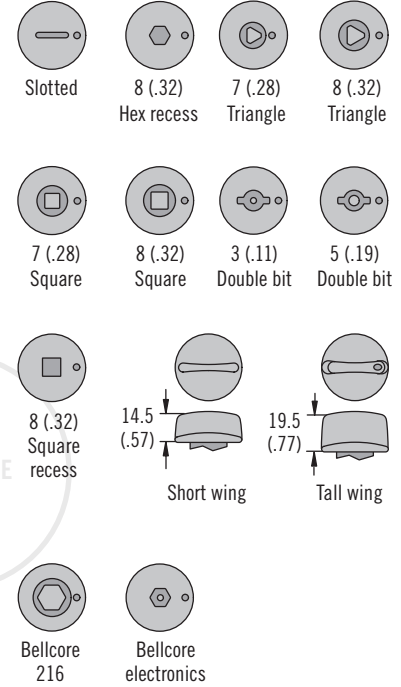

### H Head style

- 00 Slotted
- 01 8 (.32) Hex recess
- 02 7 (.28) Triangle
- 03 8 (.32) Triangle
- 04 7 (.28) Square
- 05 8 (.32) Square
- 06 3 (.11) Double bit
- 07 5 (.19) Double bit
- 08 8 (.32) Square recess
- 11 Short wing
- 12 Tall wing
- 13 Bellcore 216
- 19 Bellcore Electronics

### F Finish

- 1 Textured chrome
- 5 Black powder coated

### S Sealing option

- 0 No o-ring or external seal
- 1 O-ring and external seal to meet NEMA 4/IP65 standards

**E5 - D - H F - G S**

### D Door thickness range

- 1 1 - 6 (.039 - .236) (short housing supplied)
- 2 1 - 14 (.039 - (.551) (long housing supplied)

### G Grip table

G	Grip		G	Grip		G	Grip		G	Grip	
	Short housing	Long housing		Short housing	Long housing		Short housing	Long housing		Short housing	Long housing
00	Do not use	6 (.24)	05	8 (.31)	16 (.63)	10	18 (.71)	26 (1.02)	15	28 (1.10)	36 (1.42)
01	Do not use	8 (.31)	06	10 (.39)	18 (.71)	11	20 (.79)	28 (1.10)	16	30 (1.18)	38 (1.50)
02	2 (.08)	10 (.39)	07	12 (.47)	20 (.79)	12	22 (.87)	30 (1.18)	17	32 (1.25)	40 (1.57)
03	4 (.16)	12 (.47)	08	14 (.55)	22 (.87)	13	24 (.94)	32 (1.25)	18	34 (1.34)	42 (1.65)
04	6 (.24)	14 (.55)	09	16 (.63)	24 (.94)	14	26 (1.02)	34 (1.34)	19	36 (1.42)	44 (1.73)

If grip falls between two choices, use the smaller option

Dimensions in millimeters (inch) unless otherwise stated



[www.southco.com/E5](http://www.southco.com/E5)



# E5 Cam Latch

Glass-filled nylon · Tool or hand operated · Fixed grip

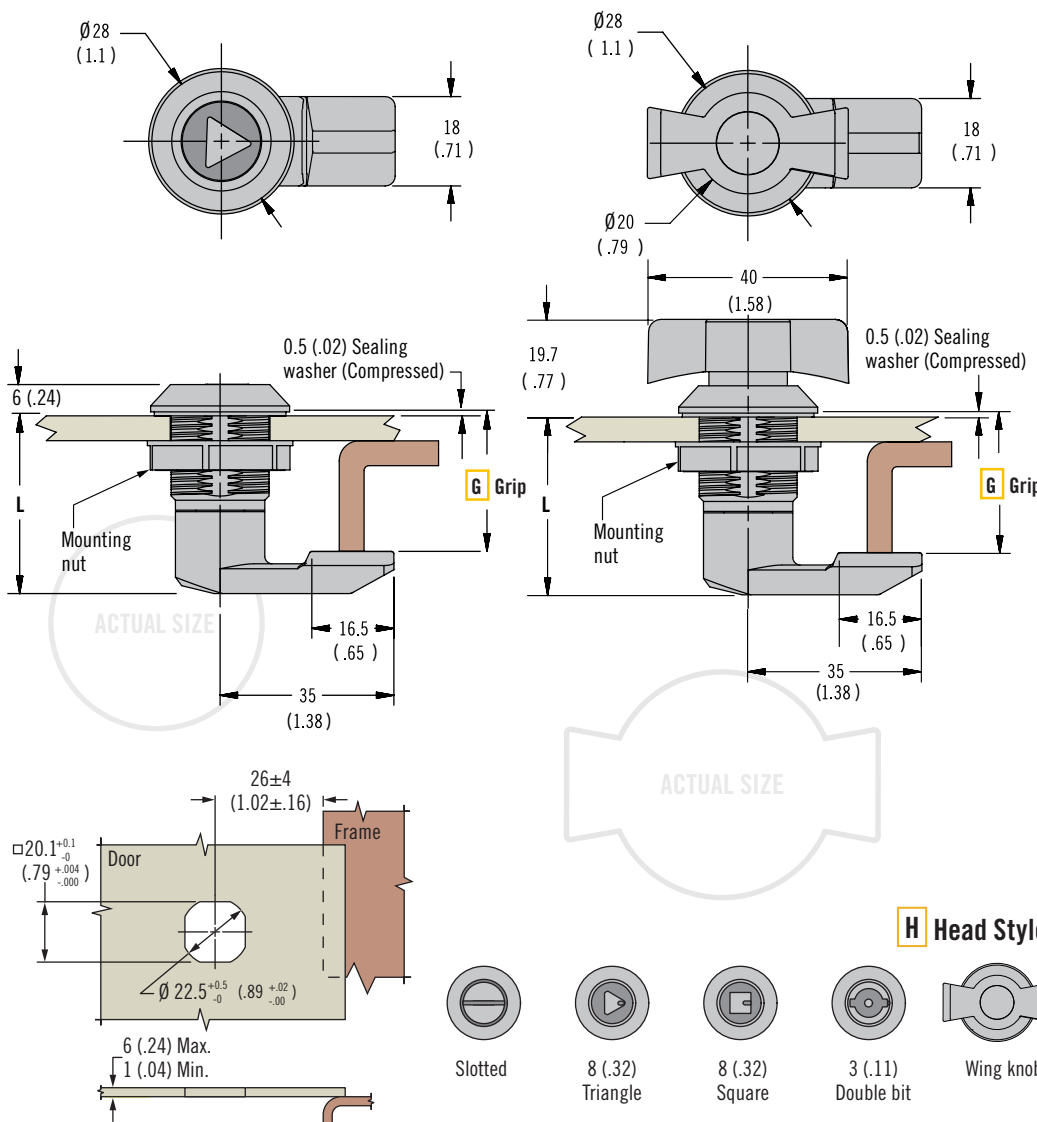

- Single hole install
- Corrosion-resistant materials

### Material and Finish

Glass-filled nylon and Stainless steel

### Performance Details

Average ultimate load:  
300 N (68 lbf)

### Installation Notes

Mounting nut  
Maximum tightening torque:  
4.25 N-m (38 in-lbf)

### Sealing Notes

NEMA 4 / IP65 achieved using gasket supplied

### Keys and Accessories

See page 130

### Latch Part Number

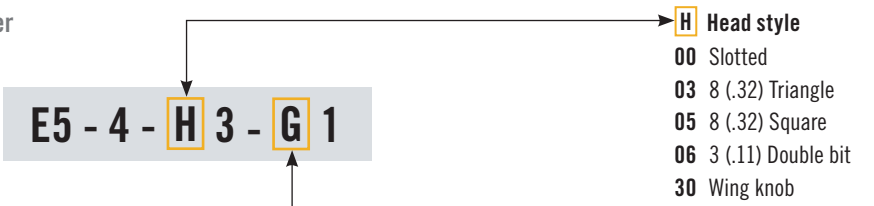

### Part Number Selection

See table

Grip table				Grip table				Grip table			
Total Grip	G	L	Max. Door Thickness for Assembled Latch	Total Grip	G	L	Max. Door Thickness for Assembled Latch	Total Grip	G	L	Max. Door Thickness for Assembled Latch
16 (.63)	16	28.1 (1.1)	5 (.20)	24 (.94)	24	34.6 (1.36)	6 (.24)	30 (1.18)	30	40.6 (1.6)	6 (.24)
18 (.71)	18	28.1 (1.1)	5 (.20)	25 (.98)	25	35.6 (1.4)	6 (.24)	32 (1.26)	32	42.6 (1.68)	6 (.24)
20 (.79)	20	28.1 (1.1)	6 (.24)	26 (1.02)	26	36.6 (1.44)	6 (.24)	34 (1.34)	34	44.6 (1.76)	6 (.24)
22 (.87)	22	32 (1.26)	6 (.24)	28 (1.10)	28	38.6 (1.52)	6 (.24)	36 (1.42)	36	46.6 (1.83)	6 (.24)





# E5 Cam Latch

Zinc · Flush cup wing style · Hand operated · Fixed grip

- Low profile
- Multiple key code options

### Material and Finish

Zinc alloy, powder coated and steel, zinc plated

### Performance Details

Maximum static load: 330 N (74 lbf)

### Installation Notes

Mounting nuts 10-24 UNC (supplied) maximum tightening torque: 3 N·m (25 in·lbf)

Screw maximum tightening torque: 10 N·m (90 in·lbf)

### Keys

See page 130

### Notes

Two point push-to-close action: Internal spring causes return of wing knob and actuator to original latched position when wing knob is released after opening. Ideal for use with cables and rotary latches.

For lock core selection and a complete overview of the *SOUTHCO*® Key-Choice System see page 158

### Single Point

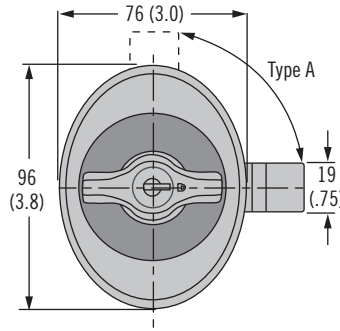

### Two Point (for use with rods)

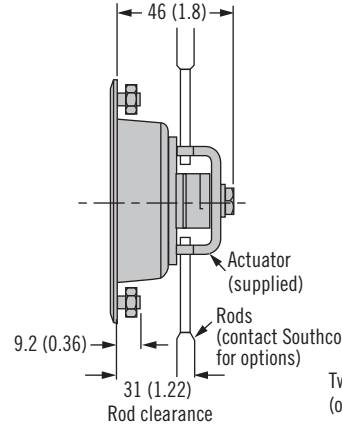

### Two Point Push-to-Close Action (spring-loaded)

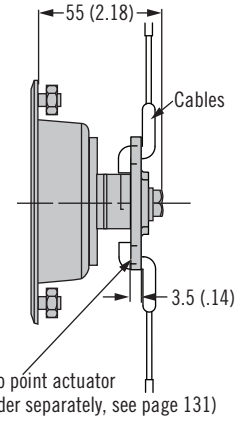

### Maximum door thickness

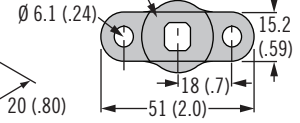
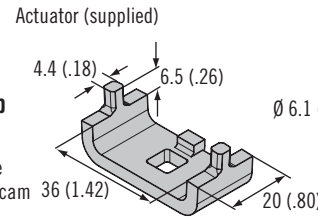
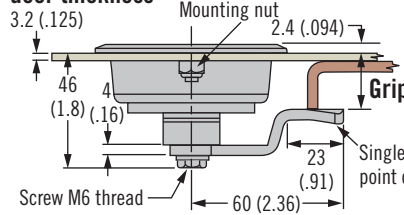

### Type A (reverse frame for type B)

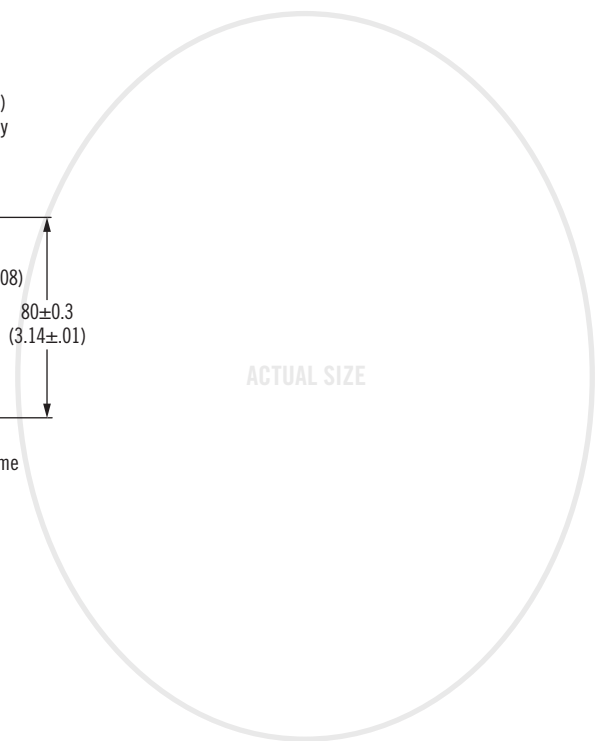
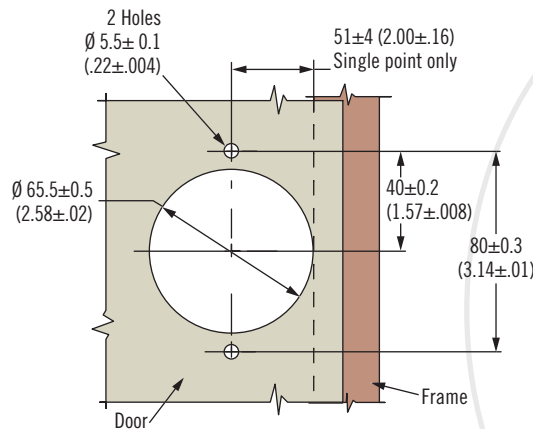



**R** Rotation

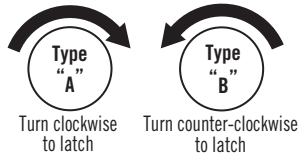

**L** Lock Styles

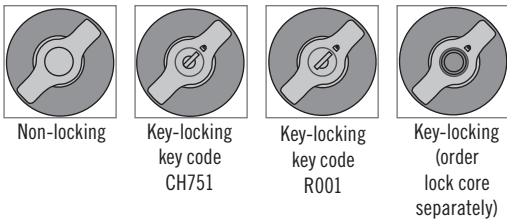

Latch Part Number (no cam)

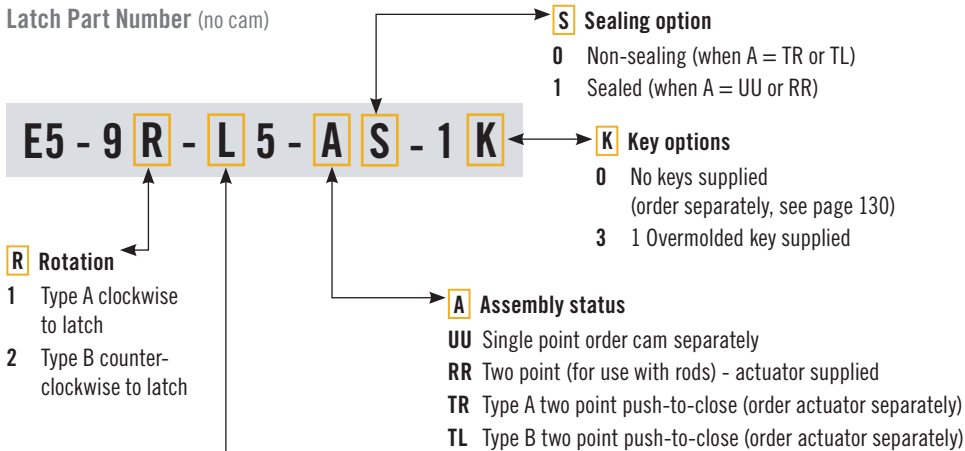

**Part Number Selection**

See table

**Single point**

Order latch and cam separately

**Two point (for use with rods)**

Order latch only  
(two point actuator supplied)

**Two point push-to-close action (spring loaded)**

Order latch and actuator separately.  
Actuator part number A5-91-201-11, see page 131 for details.  
To be used with *SOUTHCO*® R4 rotary series latches and cables see page 272.

**Cam Part Number Table (order separately from latch)**

Grip	Part Number	Grip	Part Number
22.7 (.89)	E5-6603	30.7 (1.21)	E5-6607
24.7 (.97)	E5-6604	32.7 (1.29)	E5-6608
26.7 (1.05)	E5-6605	34.7 (1.37)	E5-6609
28.7 (1.13)	E5-6606	36.7 (1.44)	E5-6610

If grip falls between two choices, use the smaller option

Dimensions in millimeters (inch) unless otherwise stated



# E5 Cam Latch

Zinc · L-handle · Hand operated · Fixed grip

- Single hole install
- Multiple key codes

### Material and Finish

Zinc alloy, powder coated or chrome plated and steel, zinc plated

### Performance Details

Maximum static load: 330 N (74 lbf)

### Sealing Notes

NEMA 4 / IP65 achieved using gasket supplied

### Installation Notes

Mounting nut: Maximum tightening torque: 10 N·m (88 in·lbf)

Screw maximum tightening torque: 10 N·m (90 in·lbf)

### Keys

See page 130

### Notes

Suitable for push-to-close action see page 128

For lock core selection and a complete overview of the *SOUTHCO*® Key-Choice System see page 158

For adjustable grip versions see page 134

### Part Number Selection

Order latch and cam separately

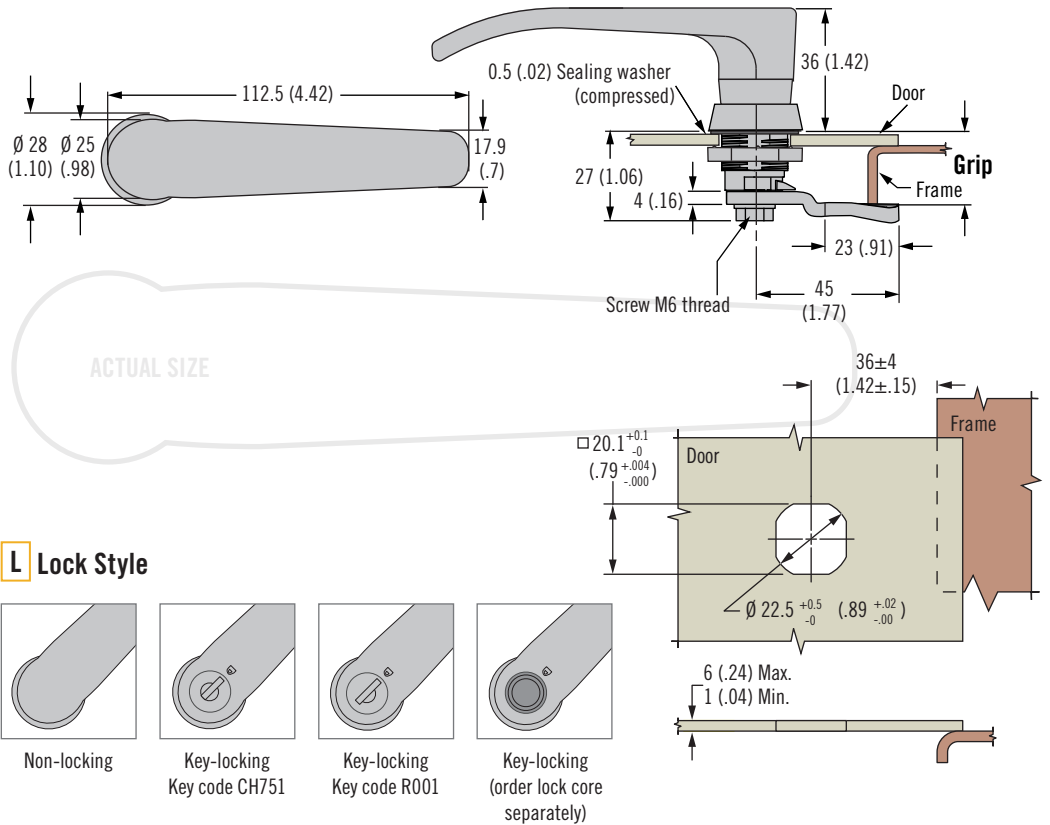

### L Lock Style

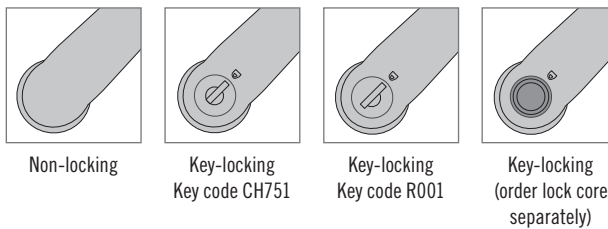

Latch Part Number (no cam)

**E5 - 9 - L F - UU1 - 1 K**

- F Finish**
- 2 Bright chrome
  - 5 Black powder coated

- L Lock style**
- 70 Non-locking (omit last two digits of part number)
  - 71 Keyed CH751 (lock core finish matches handle finish)
  - 72 Keyed R001 (stainless steel scalped shutter)
  - 73 Without lock core (omit last two digits of part number)
- Order lock core separately, see page 158

- K Key options**
- 0 No keys supplied (order separately, see page 130)
  - 3 1 Overmolded key supplied

Cam Part Number Table (order separately from latch)							
Grip	Part Number	Grip	Part Number	Grip	Part Number	Grip	Part Number
4 (.16)	E5-6003	14 (.55)	E5-6008	24 (.94)	E5-6013	34 (1.34)	E5-6018
6 (.24)	E5-6004	16 (.63)	E5-6009	26 (1.02)	E5-6014	36 (1.42)	E5-6019
8 (.31)	E5-6005	18 (.71)	E5-6010	28 (1.10)	E5-6015	38 (1.50)	E5-6020
10 (.39)	E5-6006	20 (.79)	E5-6011	30 (1.18)	E5-6016	40 (1.57)	E5-6021
12 (.47)	E5-6007	22 (.87)	E5-6012	32 (1.25)	E5-6017	42 (1.65)	E5-6022

If grip falls between two choices, use the smaller option  
 Dimensions in millimeters (inch) unless otherwise stated



# E5 Cam Latch

Zinc · T-handle · Hand operated · Fixed grip

- Single hole install
- Multiple key codes

### Material and Finish

Zinc alloy, powder coated or chrome plated and steel, zinc plated

### Performance Details

Maximum static load: 330 N (74 lbf)

### Sealing Notes

NEMA 4 / IP65 achieved using gasket supplied

### Installation Notes

Mounting nut:  
Maximum tightening torque:  
10 N·m (88 in·lbf)

Screw:  
Maximum tightening torque:  
10 N·m (90 in·lbf)

### Keys

See page 130

### Notes

Suitable for push-to-close action see page 128

For adjustable grip versions see page 134

For lock core selection and a complete overview of the *SOUTHCO*® Key-Choice System see page 158

### Part Number Selection

Order latch and cam separately

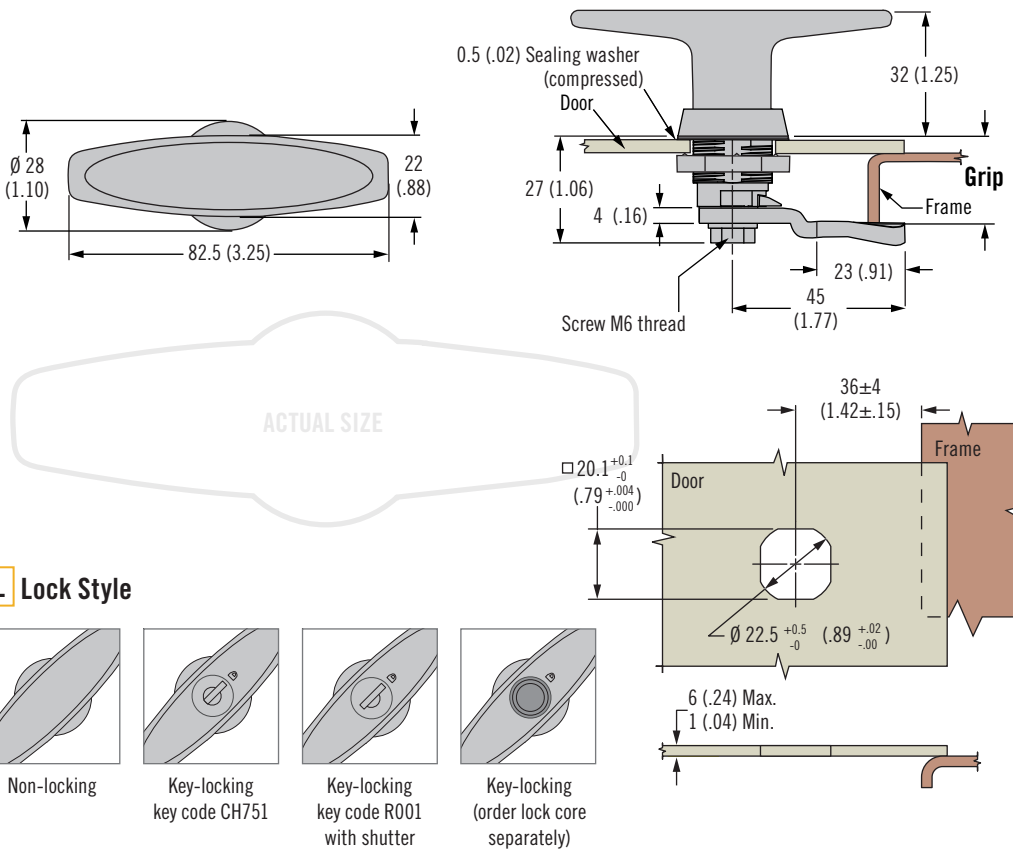

### L Lock Style

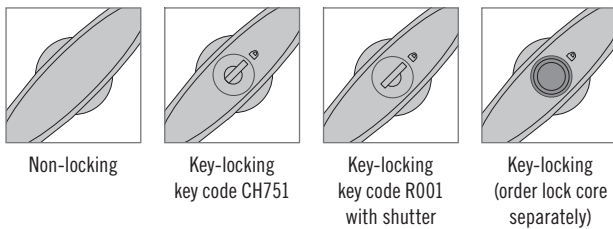

Latch Part Number (no cam)

**E5 - 9 - L F - UU1 - 1 K**

- F Finish**
- 2 Bright chrome
  - 5 Black powder coated

- L Lock style**
- 60 Non-locking (omit last two digits of part number)
  - 61 Keyed CH751 (lock core finish matches handle finish)
  - 62 Keyed R001 (stainless steel scalp shuttered)
  - 63 Without lock core (omit last two digits of part number)  
Order lock core separately, see page 158

- K Key options**
- 0 No keys supplied (order separately, see page 130)
  - 3 1 Overmolded key supplied

Cam Part Number Table (order separately from latch)							
Grip	Part Number	Grip	Part Number	Grip	Part Number	Grip	Part Number
4 (.16)	E5-6003	14 (.55)	E5-6008	24 (.94)	E5-6013	34 (1.34)	E5-6018
6 (.24)	E5-6004	16 (.63)	E5-6009	26 (1.02)	E5-6014	36 (1.42)	E5-6019
8 (.31)	E5-6005	18 (.71)	E5-6010	28 (1.10)	E5-6015	38 (1.50)	E5-6020
10 (.39)	E5-6006	20 (.79)	E5-6011	30 (1.18)	E5-6016	40 (1.57)	E5-6021
12 (.47)	E5-6007	22 (.87)	E5-6012	32 (1.25)	E5-6017	42 (1.65)	E5-6022



# E5 Cam Latch

Zinc · Wing style · Fixed grip

- Single hole install
- Multiple key codes
- Easy finger grip

### Material and Finish

Wing: Zinc alloy, black powder coated and steel, zinc plated

### Performance Details

Maximum static load: 330 N (74 lbf)

### Sealing Notes

NEMA 4 / IP65 achieved using gasket supplied

### Installation Notes

Mounting nut maximum tightening torque: 10 N·m (88 in·lbf)

Screw Maximum tightening torque: 5 N·m (45 in·lbf)

### Keys

See page 130

### Notes

Wing style suitable for push-to-close action see page 128

For lock core selection and a complete overview of the *SOUTHCO*® Key-Choice System see page 158

### Part Number Selection

Order latch and cam separately

### Wing

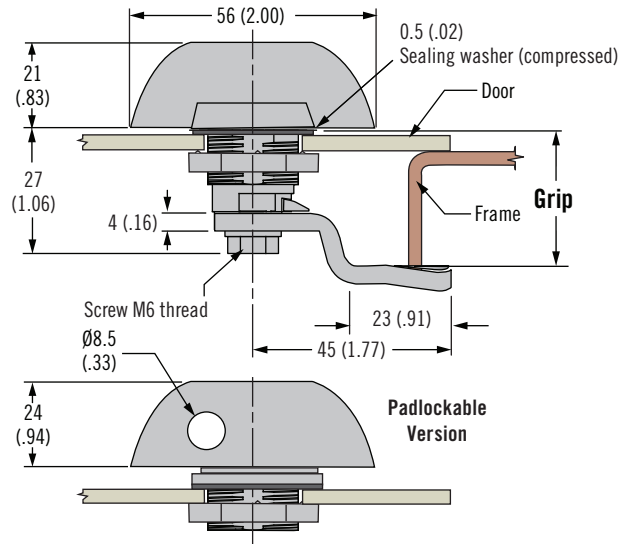
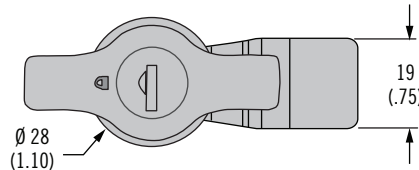

### L Lock Styles

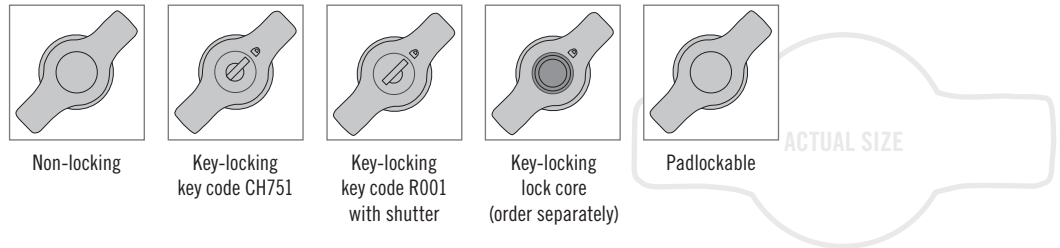

### Latch Part Number

(no cam)

**E5 - 9 - L 5 - UU1 - 1 K**

### K Key options

- 0 No keys supplied (order separately, see page 130)
- 3 1 Overmolded key supplied

### L Lock style

- 30 Non-locking (omit last two digits of part number)
- 31 Key-locking black lock core keyed alike CH751
- 32 Key-locking stainless steel scalp and shuttered lock core keyed alike R001
- 33 Without lock core (omit last two digits of part number) Order lock core separately, see page 158
- 51 Padlockable, Type A clockwise to latch (omit last two digits in part number)
- 52 Padlockable, Type B counter-clockwise to latch (omit last two digits in part number)

### Cam Part Number

**E5 - 6 L G**

### L Lock style

- 0 Non-locking or Key-locking
- 1 Padlockable

### G Grip

Grip	G	Grip	G	Grip	G	Grip	G
4 (.16)	03	14 (.55)	08	24 (.94)	13	34 (1.34)	18
6 (.24)	04	16 (.63)	09	26 (1.02)	14	36 (1.42)	19
8 (.31)	05	18 (.71)	10	28 (1.10)	15	38 (1.50)	20
10 (.39)	06	20 (.79)	11	30 (1.18)	16	40 (1.57)	21
12 (.47)	07	22 (.87)	12	32 (1.25)	17	42 (1.65)	22



[www.southco.com/E5](http://www.southco.com/E5)

Dimensions in millimeters (inch) unless otherwise stated

# E5 Cam Latch

Zinc · Cylinder lock · Fixed grip



## Cylinder Lock

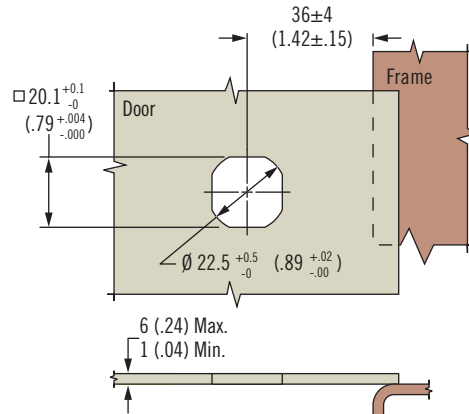
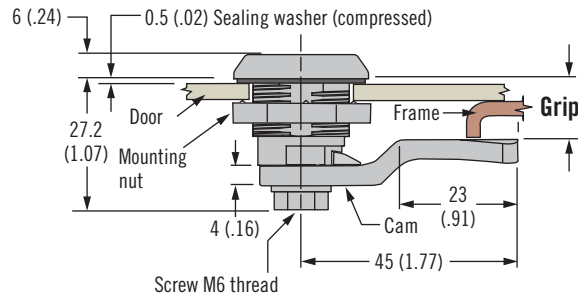
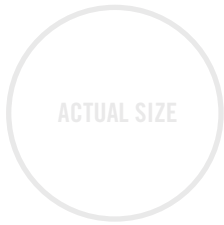
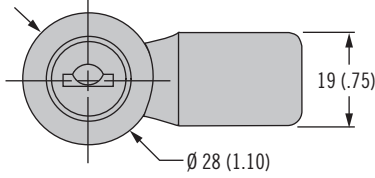

- Single hole install
- Latched / unlatched indicator

### Material and Finish

Zinc alloy, powder coated and steel, zinc plated  
Scalp stainless steel

### Performance Details

Maximum static load: 330 N (74 lbf)

### Installation Notes

Mounting nut maximum tightening torque: 10 N·m (88 in·lbf)  
Screw Maximum tightening torque: 5 N·m (45 in·lbf)

### Sealing Notes

NEMA 4 / IP65 achieved using gasket supplied

### Keys and Accessories

See page 130

### Notes

Suitable for push-to-close action see page 128.  
See page 126 for cam part numbers

### Part Number Selection

See table

Order latch and cam separately

#### F Finish

- 2 Bright chrome
- 5 Black powder coated

#### K Key options CH751

- 0 No keys supplied (order separately, see page 130)
- 2 2 Flat keys supplied

Latch Part Number  
(no cam)

**E5 - 5 - 40 F - UU1 - 1 K**



# E5 Cam Latch

Zinc · Push-to-close · Hand, key or tool operated · Single and two point

- Single hole installation
- Latched / unlatched indicator
- Push-to-close action

### Material and Finish

Zinc alloy, powder coated and steel, zinc plated

### Performance Details

Maximum static load: 330 N (74 lbf)

### Installation Notes

Mounting nut maximum tightening torque: 10 N·m (88 in-lbf)

Screw Maximum tightening torque: 5 N·m (45 in-lbf) for two point actuator only

### Keys and Accessories

See page 130

### Notes

Single Point: Push-to-close action in unlocked position only and key inserted (cylinder lock)

Two Point: Order actuator separately (see page 131)

For lock core selection and a complete overview of the *SOUTHCO*® Key-Choice System see page 158

### Actuator Part Number

See page 131 for details

Two point to be used with *SOUTHCO*® R4 rotary series latches and cables see page 272

Two point push to close action: Internal spring causes return of driver and actuator to original latched position when driver is released after opening. Ideal for use with cables and rotary latches.

### Single Point Spring-Loaded (Type A tool operated shown)

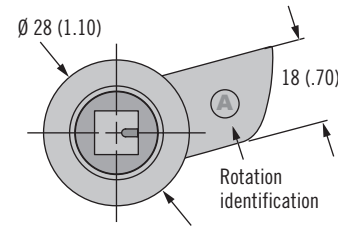

### Operation

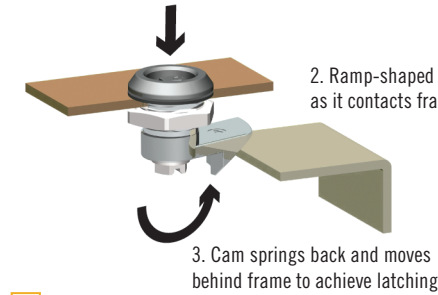

### Rotation

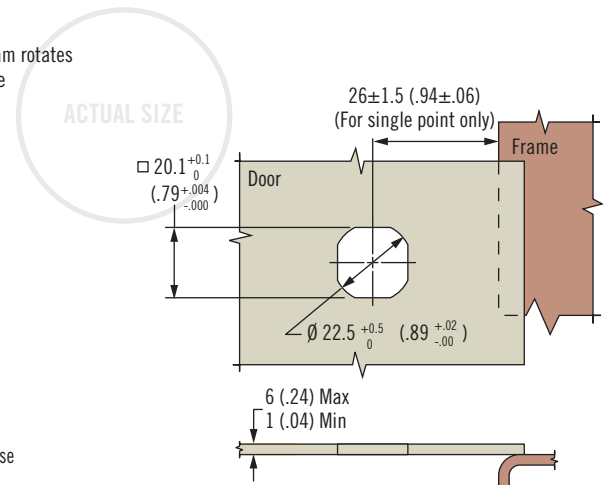
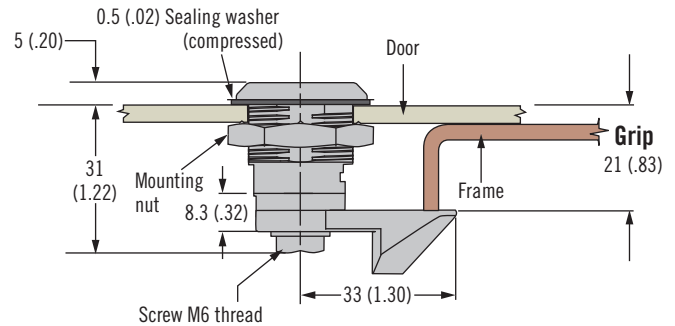
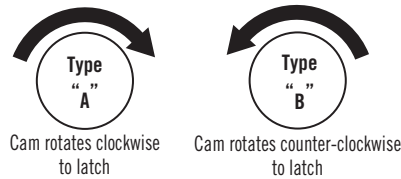

### Two Point Spring-Loaded (Type A hand operated shown)

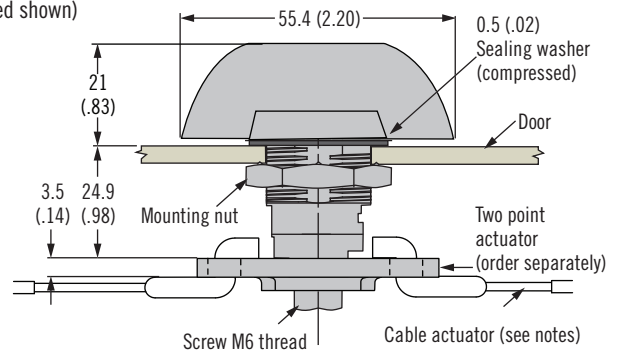
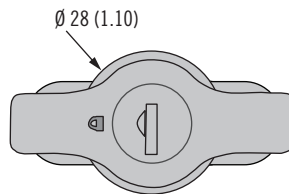

### Two Point Actuator for bare cable

(order separately, see page 132)

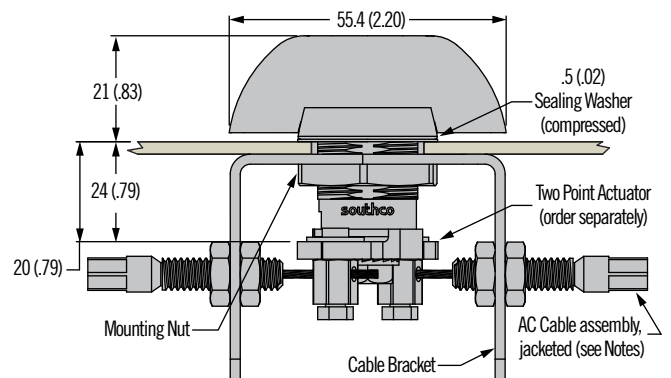

### Hand / Key Operated

### Part Number Selection

Latch supplied fully assembled



**F** Finish  
 2 Bright chrome (not available for wing type)  
 5 Black powder coated

**T** Type  
 5 Cylinder lock keyed alike CH751  
 9 Wing / T-handle / L-handle

**R** Rotation  
 51 Type A single point (for visual identification cam stamped A or B)  
 52 Type B single point (for visual identification cam stamped A or B)  
 TR Type A two point (order actuator separately)  
 TL Type B two point (order actuator separately)

**K** Key options  
 0 No keys supplied (order separately, see page 130)  
 3 1 Overmolded key supplied

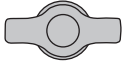
**E5 - T - L F - R 0 - 1 K**

Lock style	T = 5	T = 9		
				
	Cylinder Lock	Wing	T-handle	L-handle
Non-locking (omit last two digits of part number)	~	30	60	70
Keyed CH751 (lock core finish matches handle finish)	~	31	61	71
Keyed CH751 (stainless steel scalp shuttered)	40	~	~	~
Keyed R001 reversible (stainless steel scalp shuttered)	~	32	62	72
Without lock core (omit last two digits of part number) (to be ordered separately see page 158)	~	33	63	73

### Tool Operated

#### H Head Styles

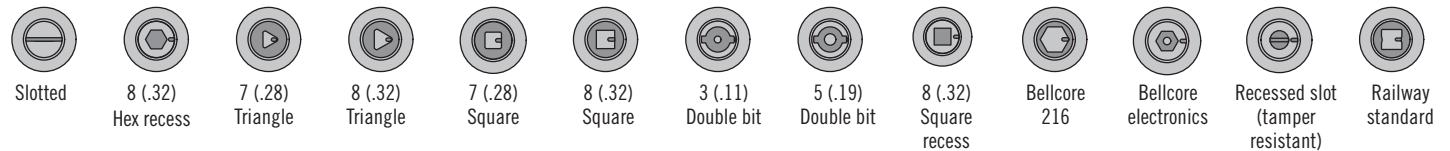

### Part Number Selection

Latch supplied fully assembled

**F** Finish  
 2 Bright chrome  
 5 Black powder coated

**H** Head style  
 00 Slotted  
 01 8 (.32) Hex recess  
 02 7 (.28) Triangle  
 03 8 (.32) Triangle  
 04 7 (.28) Square  
 05 8 (.32) Square  
 06 3 (.11) Double bit  
 07 5 (.19) Double bit  
 08 8 (.32) Square recess  
 13 Bellcore 216  
 19 Bellcore electronics  
 21 Recessed slot (tamper resistant)  
 22 Railway standard

**R** Rotation  
 51 Type A single point (for visual identification, cam stamped A or B)  
 52 Type B single point (for visual identification, cam stamped A or B)  
 TR Type A two point (order actuator separately)  
 TL Type B two point (order actuator separately)

**E5 - 6 - H F - R 0**





# E5 Cam Latch

Zinc · Tool or hand operated · Fixed grip · Mini size

- Single hole install
- Compact size
- Minimal panel intrusion

### Material and Finish

Zinc alloy, powder coated and steel, zinc plated

### Performance Details

Maximum static load: 130 N (29 lbf)

### Installation Notes

Mounting nut maximum tightening torque: 5 N·m (45 in-lbf)

Screw Maximum tightening torque: 1 N·m (9 in-lbf)

### Sealing Notes

NEMA 4 / IP65 achieved using gasket supplied

### Key part numbers

- 6mm (.24) Triangle
- E3-19-3
- 6mm (.24) Square
- E3-20-3



### Part Number Selection

Order latch and cam separately

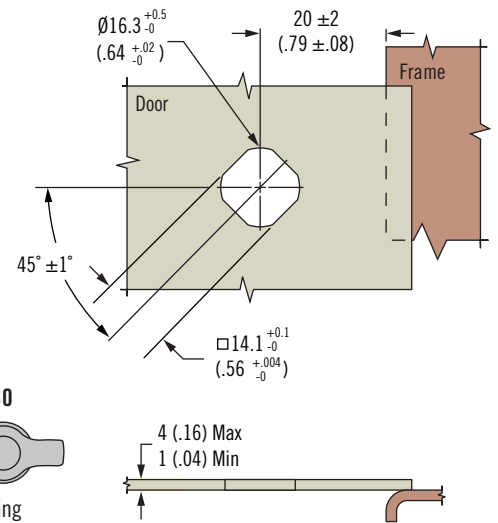
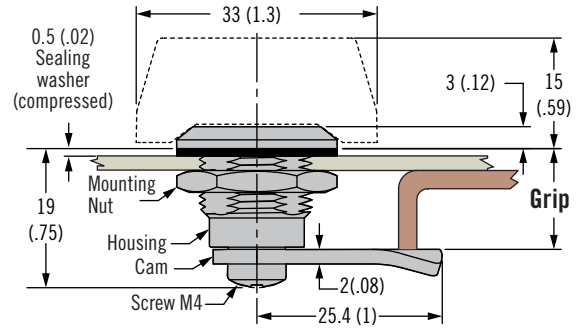
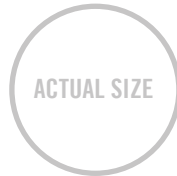
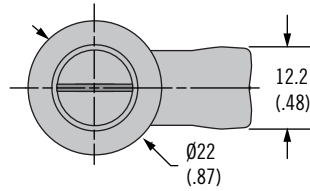

### H Head style

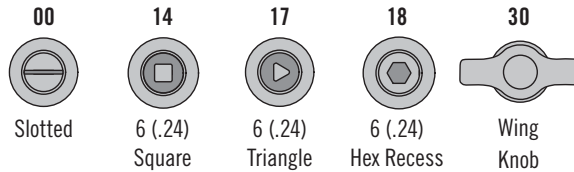

### Latch Part Number (no cam)

**E5 - M - H F - UU1**

- F Finish**
- 2 Bright chrome
  - 5 Black powder coated

- H Head style**
- 00 Slotted
  - 14 Square 6mm
  - 17 Triangle 6mm
  - 18 Hex Recess 6mm
  - 30 Wing Knob

Cam Part Number Table (order separately from latch)			
Grip	Part Number	Grip	Part Number
4 (.16)	E5-3005	16 (.63)	E5-3011
6 (.24)	E5-3006	18 (.71)	E5-3012
8 (.31)	E5-3007	20 (.79)	E5-3013
10 (.39)	E5-3008	22 (.87)	E5-3014
12 (.47)	E5-3009	24 (.94)	E5-3015
14 (.55)	E5-3010	26 (1.02)	E5-3016





# E5 Cam Latch Accessories

## Keys and Flush Mount Bracket

### Material and Finish

- Tool key: Zinc alloy or nylon
- Overmolded key: Nickel plated and ABS plastic black
- Flat key: Nickel plated

### Overmolded Keys



### Flat Keys

Key CH751



### Part Number

- Overmolded key CH751:
  - Single: PK-10-10-05
  - Pair: PK-10-01-05
- Overmolded key R001:
  - Single: PK-10-10-05-KR001
  - Pair: PK-10-01-05-KR001
- Flat key
  - Pair: PK-10-01

### Material and Finish

Stainless steel or galvanized steel with rubber o-ring

### Notes

- For use with tool operated standard series cam latches, see pages 118-119, 121, 127
- See page 91 for door preparation dimensions

### Keys Zinc or Nylon

- H** Head style
- 2 3 (.11) Double bit
  - 3 7 (.28) Triangle
  - 4 7 (.28) Square
  - 7 8 (.32) Triangle
  - 8 8 (.32) Square recess
  - 9 5 (.19) Double bit
  - 10 8 (.32) Square male (zinc only)
  - 11 Bellcore electronics
  - 12 Bellcore 216 (zinc only)
  - 14 Railway Standard (zinc only)

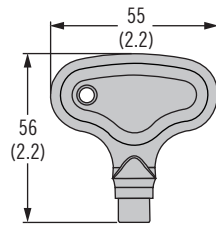

- F** Finish
- 1 Plated zinc
  - 2 Natural zinc
  - 3 Nylon, black



### Keys Nylon

- H** Head style
- 19 6 (.24) Triangle
  - 20 6 (.24) Square

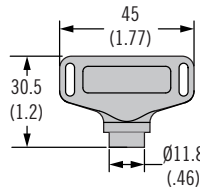

### Head Styles

- 2 3 (.11) Double bit
- 3 7 (.28) Triangle
- 4 7 (.28) Square
- 7 8 (.32) Triangle
- 8 8 (.32) Square recess
- 9 5 (.19) Double bit
- 10 8 (.32) Square male
- 11 Bellcore electronics
- 12 Bellcore 216
- 14 Railway Standard
- 19 6 (.24) Triangle
- 20 6 (.24) Square

### Flush Mount Bracket

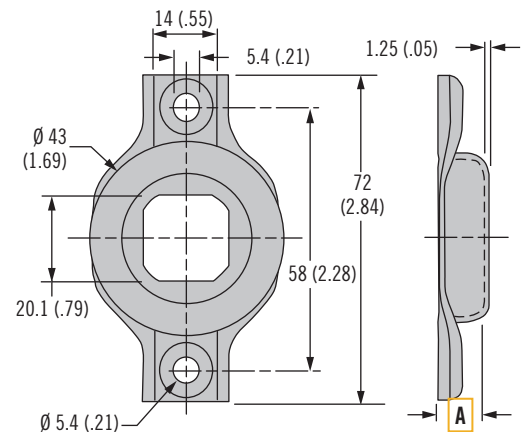
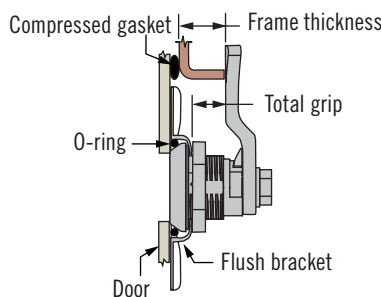

A	Part Number	Material
6.6	E5-77-1-12	Galvanized steel
6.6	E5-77-1-24	304 Stainless steel

To calculate the **Total Grip**, use the following formula: **Frame Thickness + Compressed Gasket - A**. Use this **Total Grip** with the appropriate E5 tables in the *SOUTHCO* Handbook to determine cam type.

Dimensions in millimeters (inch) unless otherwise stated

# E5 Cam Latch Accessories

## Multi-point actuators · Dummy cam



### Multi-Point Actuator

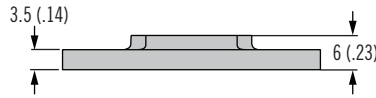
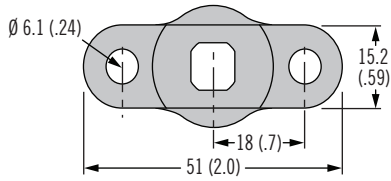

#### Part Number

A5-91-201-11

### Material and Finish

Zinc alloy

### Notes

Actuator plate (for multi-point see page 272 for cable assembly)  
(Not recommended for Cylinder Lock version)

Not to be used with low profile E5

### Multi-Point Actuator - Low Profile

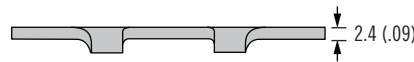
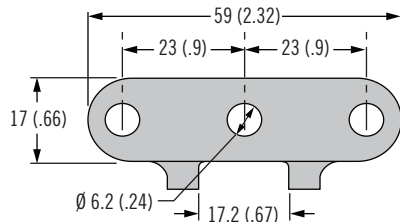

#### Part Number

A8-4-01-03

### Material and Finish

Steel, plated

### Notes

Actuator plate (for multi-point see pages 198-199 for rods)

For use with all E5 latches

### Multi-Point Actuator

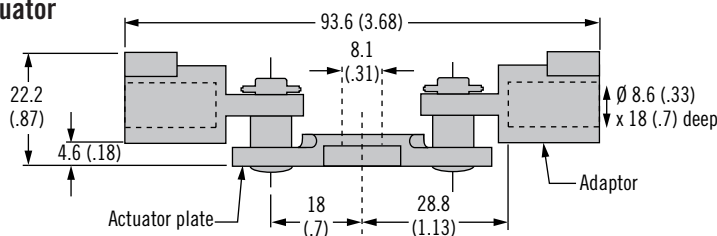

#### Part Number

A5-90-101-11

### Material and Finish

Zinc alloy and steel, zinc plated

### Notes

Actuator plate (for multi-point see page 198 for rods)

Not to be used with low profile E5

### Dummy Cam

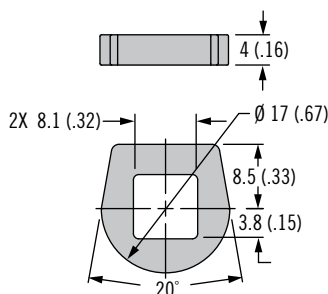

#### Part Number

Steel	H3-0-45688
Stainless Steel	H3-0-45688-24

### Material and Finish

Steel, stainless steel

### Notes

Replaces cam when used with actuator plate A5-90-101-11 in order to create a 2-point latching system



# E5 Cam Latch Accessories

Hooked cam · Multi-point actuator · Cable brackets

## Material and Finish

Steel plated

Hook cam: Steel, plated

Multi-point actuator: Zinc alloy, plated

Cable bracket: Steel, plated

## Notes

Not to be used with low profile E5

## Hooked Cam

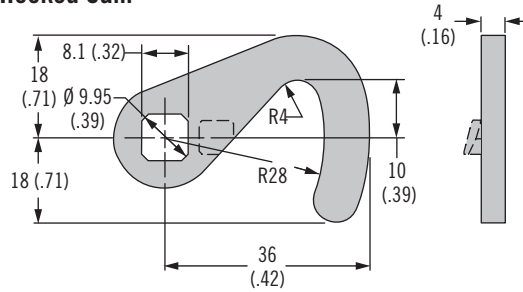

Hooked Cam Part Number	
E5-6200	No stop
E5-6210	Stop for clockwise rotation
E5-6220	Stop for counter-clockwise rotation

## Multi-Point Actuator

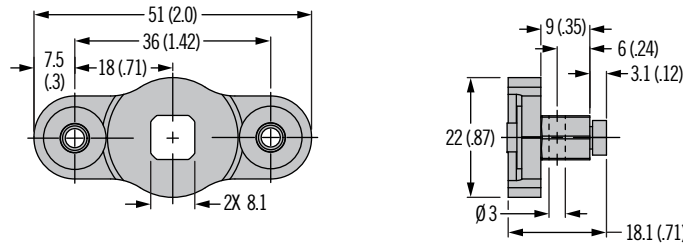

Part Number
A5-99-136

## Cable Bracket – Counter Clockwise Rotation

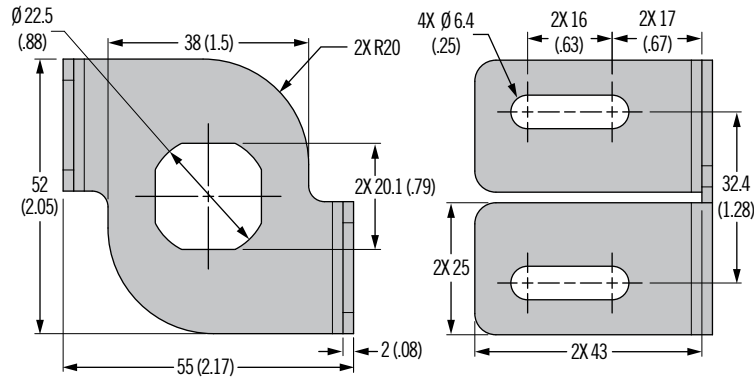

Part Number
AC-0-49617-11-L

## Part Number

See table

## Notes

See page 272 for additional cable assembly selections

## Cable Bracket – Clockwise Rotation

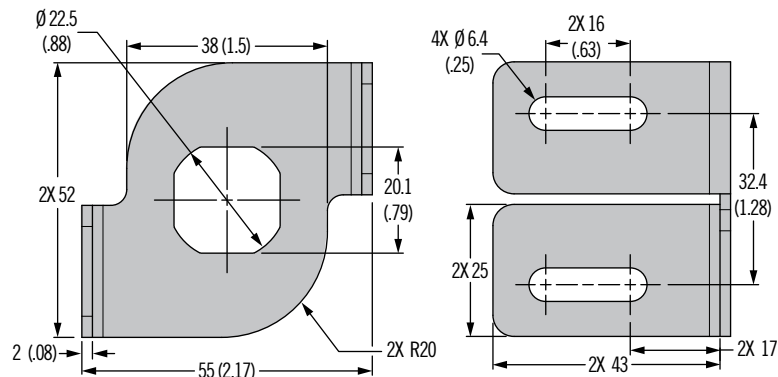

Part Number
AC-0-49617-11-R

Dimensions in millimeters (inch) unless otherwise stated



[www.southco.com/E5](http://www.southco.com/E5)

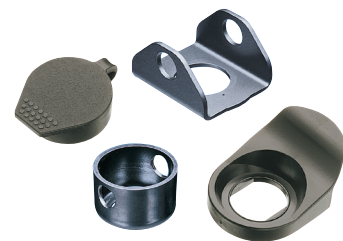

# E5 Cam Latch Accessories

Sealing cover · Sealing washer · Pull tab · Padlock bracket

## Sealing Cover

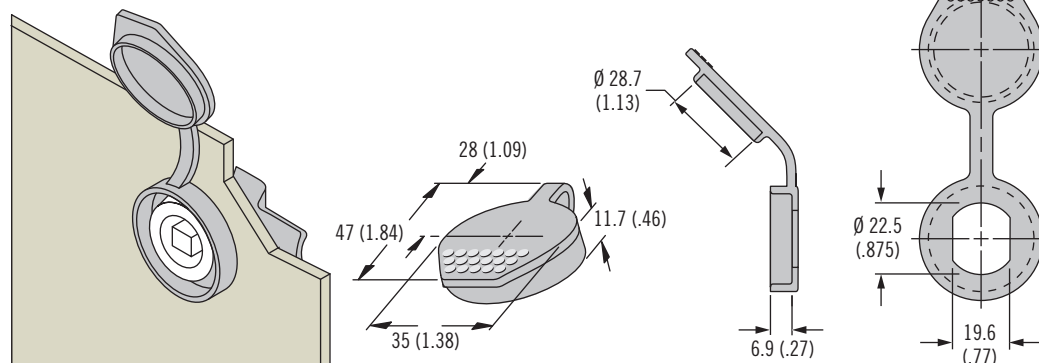

## Sealing Washer

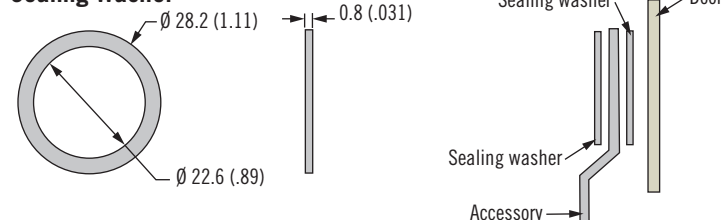

Type	Part Number	Grip Adjustment Formula
Sealing washer	E5-17	Add 0.4 (0.02) compressed height to door thickness
Sealing cover	90-3	Add 2.3 (.090) to door thickness

## Pull Tab

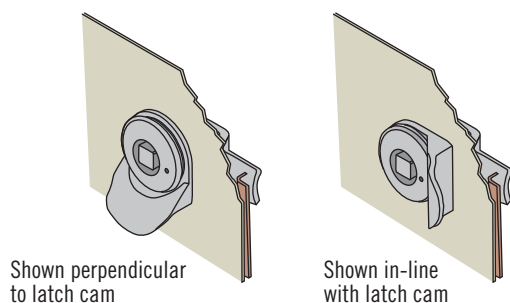
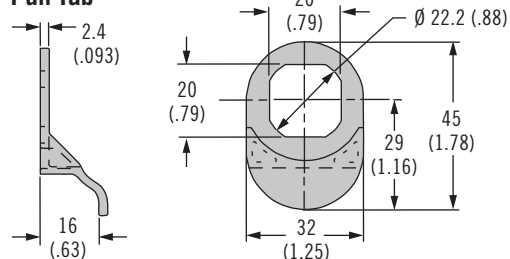

## Padlock Bracket (Round)

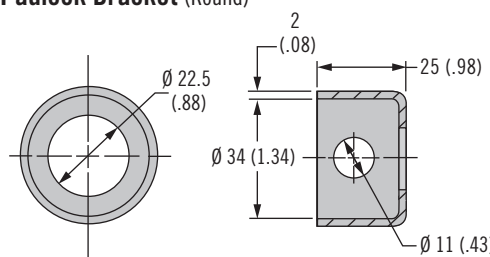

## Padlock Bracket (Square)

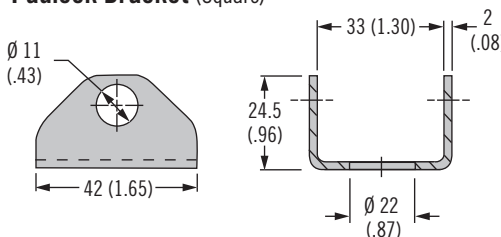

Type	Part Number	Grip Adjustment Formula
Padlock bracket square	E3-77-101-31	Add 2 (.08) to door thickness
Padlock bracket round	E3-77-102-31	Add 2 (.08) to door thickness
Pull tab	E5-18	Add 2.4 (.093) to door thickness

## Material and Finish

Sealing washer: Neoprene natural  
Sealing cover: Thermoplastic elastomer, black

## Installation Notes

To provide sealing: use two sealing washers and add compressed thickness of each washer and accessory thickness to your door thickness range.

## Notes

Sealing washer for use with all E5 products  
Sealing cover for use with tool operated and cylinder lock E5 only

## Part Number

See table

## Material and Finish

Padlock bracket: Stainless steel, black powder coated  
Pull tab: Nylon, black

## Installation Notes

To provide sealing: use two sealing washers and add compressed thickness of each washer and accessory thickness to your door thickness range.

## Notes

Padlock brackets and pull tabs for use with tool operated and cylinder lock E5 only

## Part Number

See table