

REVISION HISTORY			
REV	DATE	BY	DESCRIPTION
E	07FEB2018	VK/YGC	PRN: P2018-0350

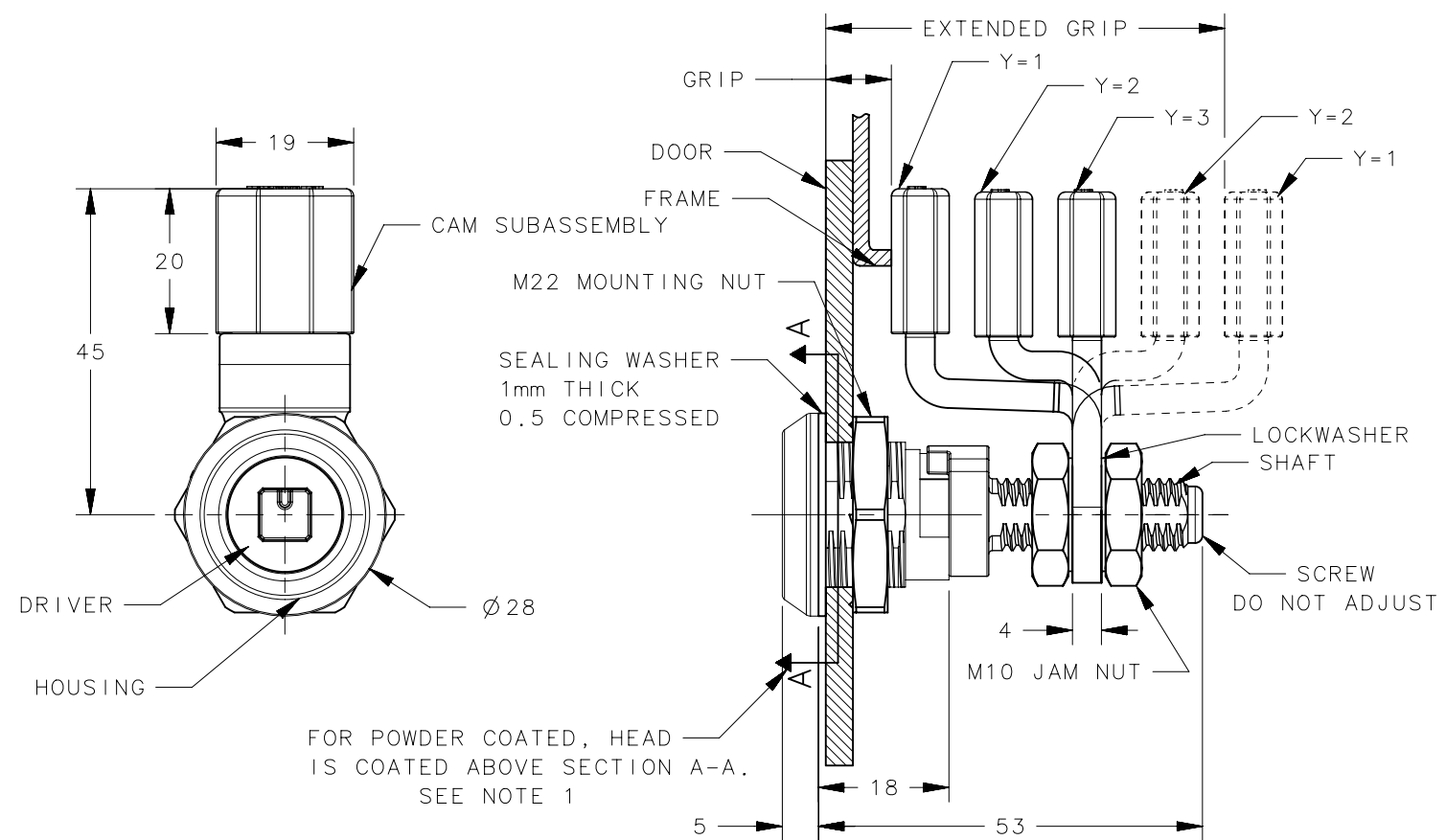

FOR POWDER COATED, HEAD IS COATED ABOVE SECTION A-A. SEE NOTE 1

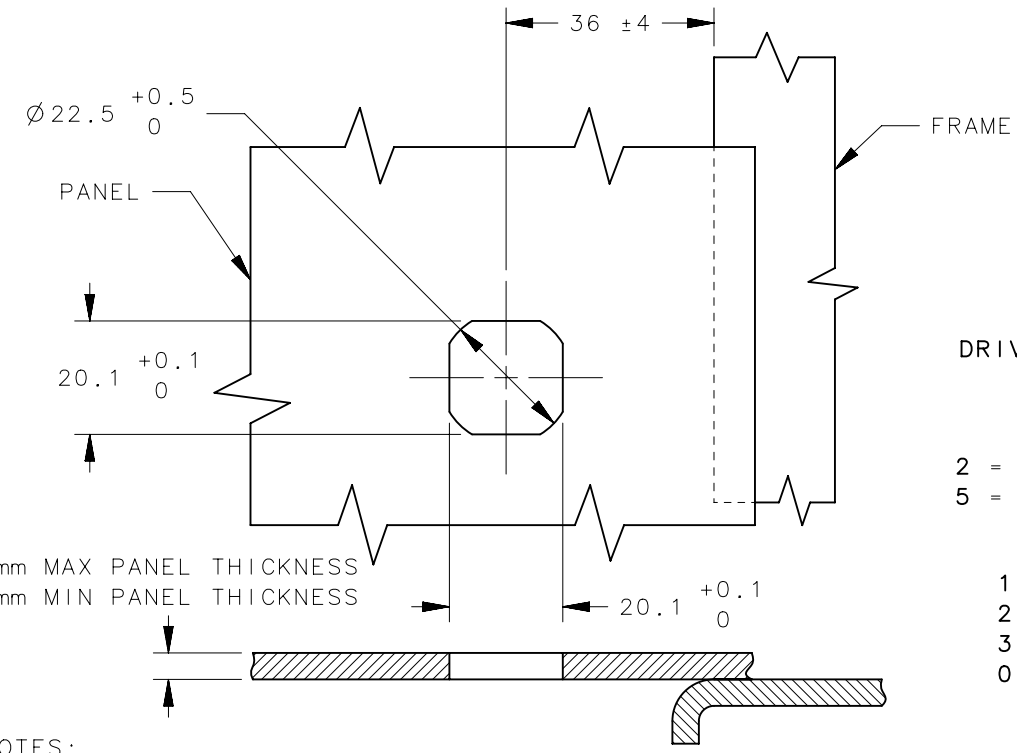

E5-6-WWX-Y1

DRIVER ACTUATION STYLE

FINISH

- 2 = BRIGHT CHROME PLATE
- 5 = BLACK POWDER COAT

CAM TYPE

- 1 = DEEP OFFSET CAM
- 2 = OFFSET CAM
- 3 = STRAIGHT CAM
- 0 = NO CAM(CAM ORDER SEPARATELY)

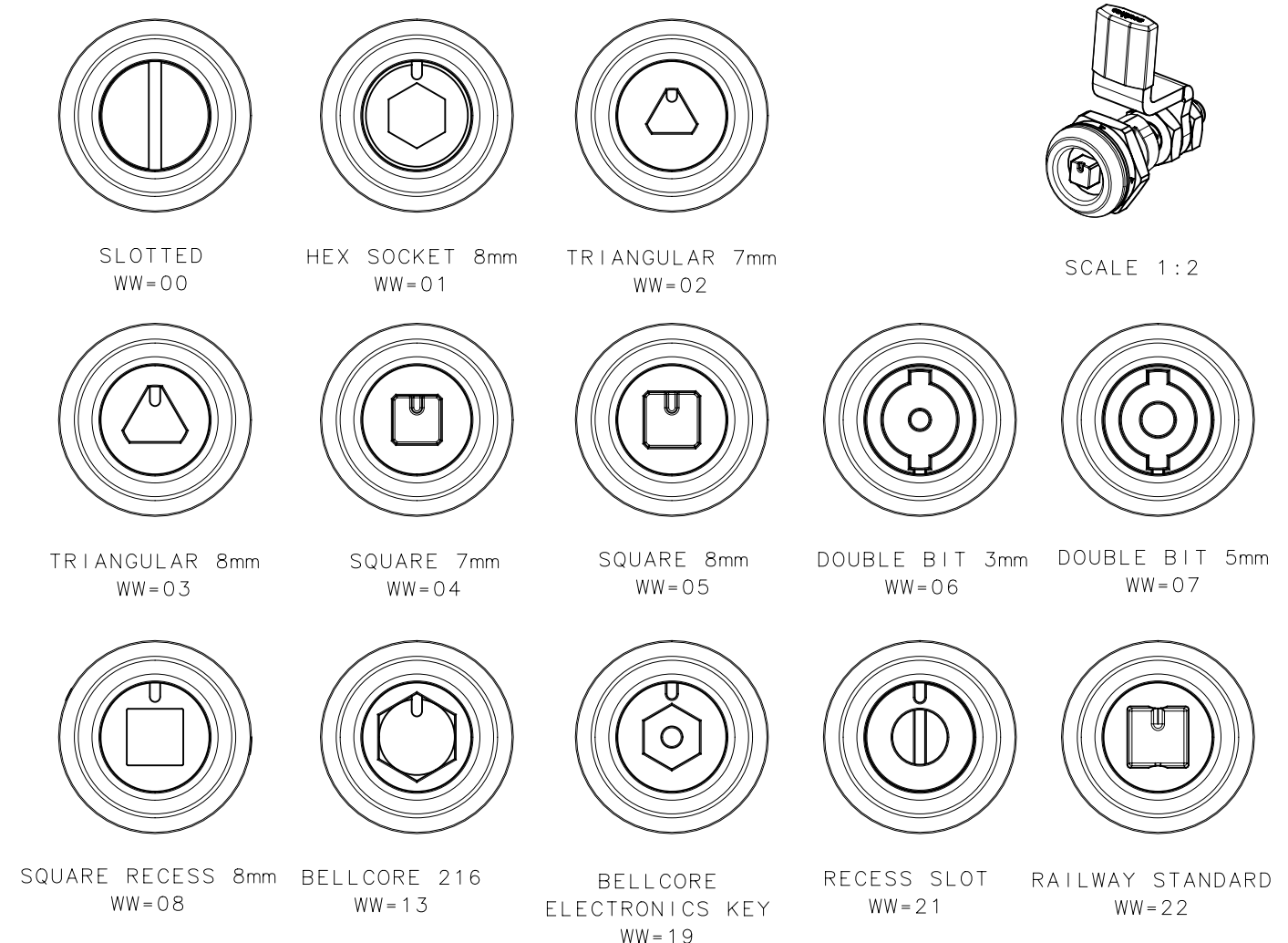

GRIP TABLE

Y	DESCRIPTION	GRIP RANGE(FORWARD)	GRIP RANGE(REVERSE)	CAM PART NUMBER
1	DEEP OFFSET, CAM	5mm-16.5mm	51mm-62.5mm	E5-4001
2	OFFSET, CAM	16.5mm-28mm	39.5mm-51mm	E5-4002
3	STRAIGHT, CAM	28mm-39.5mm		E5-4003

11	-	2	LOCKWASHER	SPRING STEEL	ZINC PLATE PLUS YELLOW CHROMATE
10	-	2	M10 JAM NUT	STEEL	ZINC PLATE PLUS BRIGHT CHROMATE
9	-	1	SCREW	STEEL	ZINC PLATE PLUS BRIGHT CHROMATE
8	-	1	SHAFT	DIE CAST ZINC	NATURAL
7	-	1	SPRING	MUSIC WIRE	ZINC PLATE PLUS BRIGHT CHROMATE
6	-	1	HOUSING	DIE CAST ZINC	SEE TABLE
5	-	1	CAM SUBASSEMBLY	SEE NOTE 4	SEE NOTE 4
4	-	1	M22 MOUNTING NUT	DIE CAST ZINC	BRIGHT CHROMATE
3	-	1	O-RING	BUNA N	NATURAL
2	-	1	SEALING WASHER	LDPE (LOW DENSITY POLYETHYLENE)	BLACK
1	-	1	DRIVER	DIE CAST ZINC	SEE TABLE
-	E5-6-WWX-Y1	-	ASSEMBLY	-	-
NO.	PART NUMBER	QTY	TYPE OF COMPONENT	MATERIAL	FINISH

NOTES:

1. COSMETIC SPECIFICATION:
ALL SURFACES ABOVE A-A CONFORM TO CLASS "C" DESIGNATION AS DESCRIBED IN SOUTHCO COSMETIC SPECIFICATIONS: S-121-01 FOR X = 2 AND S-121-03 FOR X = 5
2. INSTALLATION:
A. INSERT LATCH INTO HOLE IN DOOR. CHECK FOR PROPER ORIENTATION AND OPERATION USING PAWL.
B. INSTALL MOUNTING NUT(M22 ACROSS FLATS). TIGHTENING TORQUE IS 10Nm MAX.
C. INSTALL JAM NUT, LOCKWASHER, PAWL, LOCKWASHER AND JAM NUT ON SHAFT. ADJUST JAM NUTS TO POSITION PAWL AT CORRECT GRIP (WITH LATCH CLOSED). TIGHTENING TORQUE IS 7Nm MAX, USING TWO 17mm WRENCHES.
3. CAM AND HARDWARE SHIPPED UNASSEMBLED FROM LATCH.
4. MATERIAL AND FINISH OF CAM SUBASSEMBLY: CAM: STEEL, ZINC PLATE PLUS BRIGHT CHROMATE
COVER: NYLON, BLACK

THIRD ANGLE PROJECTION		<p>CONNECT · CREATE · INNOVATE</p>	
MILLIMETERS [IN]			
TOLERANCES UNLESS OTHERWISE NOTED		DESCRIPTION E5 METAL QUAD LATCH (TOOL SECURED) ADJUSTABLE GRIP	
ALL DIMENSIONS WITHOUT TOLERANCES ARE FOR REFERENCE ONLY.		SIZE A3	SYSTEM NX
PER ASME Y14.5M-1994		DWG NO. J-E5-6-1	SCALE 1:1
DRAWN BY VK		DATE 14DEC2016	SHEET 1 OF 1