

# E5 Cam Latch

Zinc · Tool operated · Adjustable grip

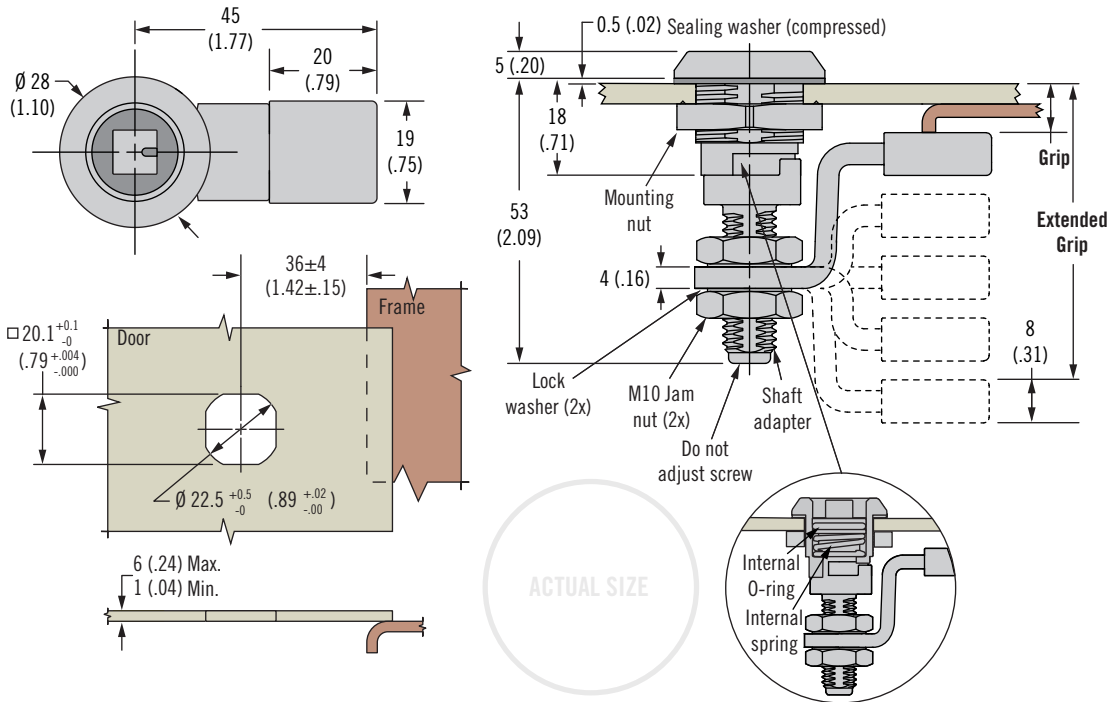

118A



- Single hole install
- Latched / unlatched indicator
- Easy grip adjustment
- Tool operated for security

## Material and Finish

Zinc alloy, powder coated or chrome plated and steel, zinc plated

## Performance Details

Maximum static load: 330 N (74 lbf)

## Installation Notes

Position cam so latching function can be achieved comfortably by hand. Recommended tightening torque for mounting nut is 10 N·m (88 in·lbf) max, and jam nut is 7 N·m (62 in·lbf)

## Sealing Notes

NEMA 4 / IP65 achieved using gasket supplied

## Keys and Accessories

See page 130

## Part Number Selection

See table

Order latch and cam separately

## H Head Styles

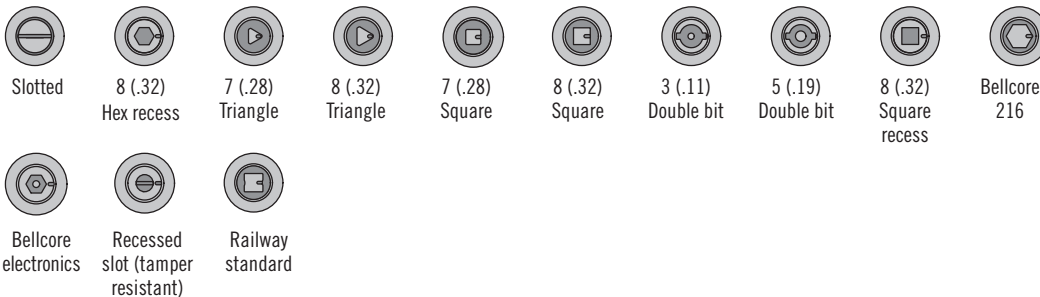

Latch Part Number (no cam)

**E5 - 6 - H F - 01**

## H Head style

- 00 Slotted
- 01 8 (.32) Hex recess
- 02 7 (.28) Triangle
- 03 8 (.32) Triangle
- 04 7 (.28) Square
- 05 8 (.32) Square
- 06 3 (.11) Double bit
- 07 5 (.19) Double bit
- 08 8 (.32) Square recess
- 13 Bellcore 216
- 19 Bellcore electronics
- 21 Recessed slot (tamper resistant)
- 22 Railway standard

## F Finish

- 2 Bright chrome
- 5 Black powder coated

Cam Part Number Table (order separately from latch)

Minimum Grip +2(.08) - 0 (.00)	Maximum Grip +2(.08) - 0 (.00)	Cam Type	Part Number
5 (.20)	16.5 (.65)	Deep Offset Cam, Forward	E5-4001
51 (2.01)	62.5 (2.46)	Deep Offset Cam, Reversed	
16.5 (.65)	28 (1.10)	Offset Cam, Forward	E5-4002
39.5 (1.56)	51 (2.01)	Offset Cam, Reversed	
28 (1.10)	39.5 (1.56)	Straight Cam	E5-4003