

REVISION HISTORY			
REV	DATE	BY	DESCRIPTION
B	22FEB2018	JJT/MJS	PRN: P2018-0461

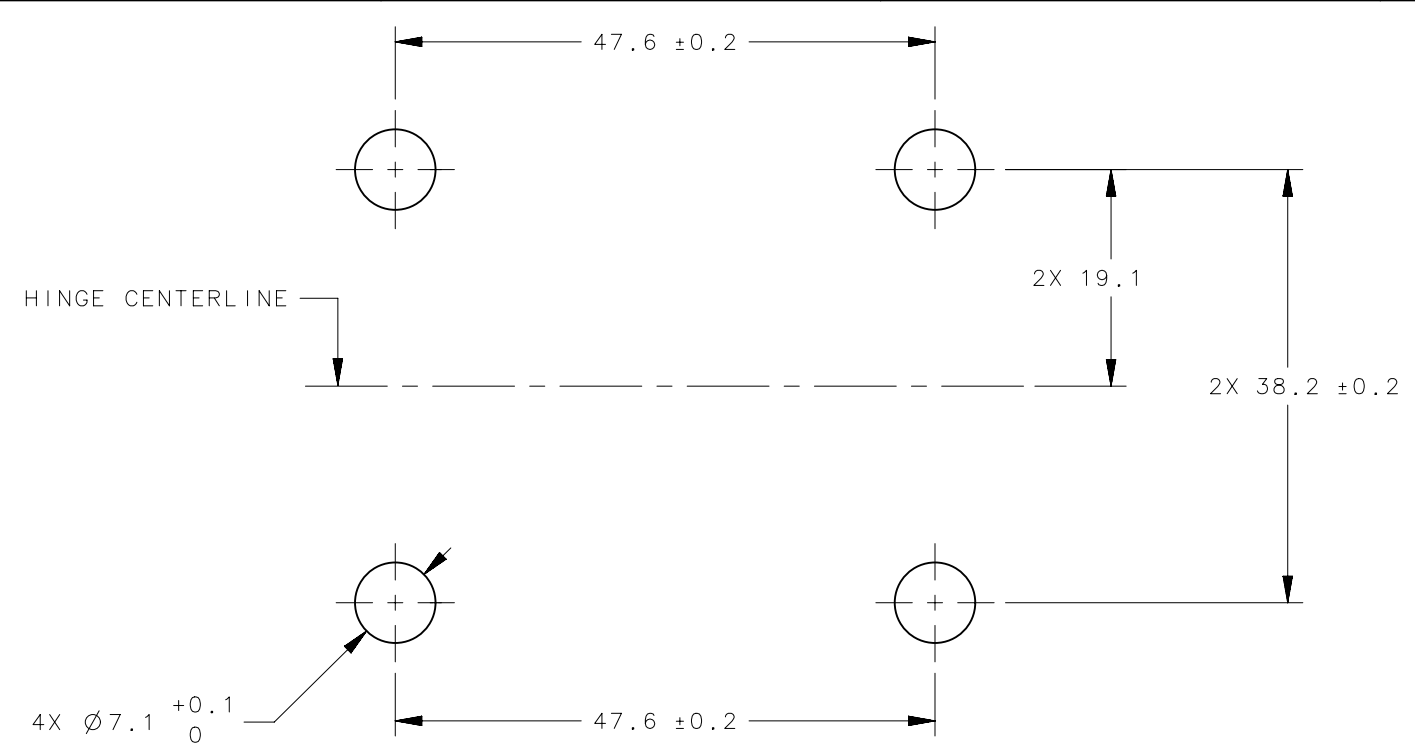

PANEL PREPARATION

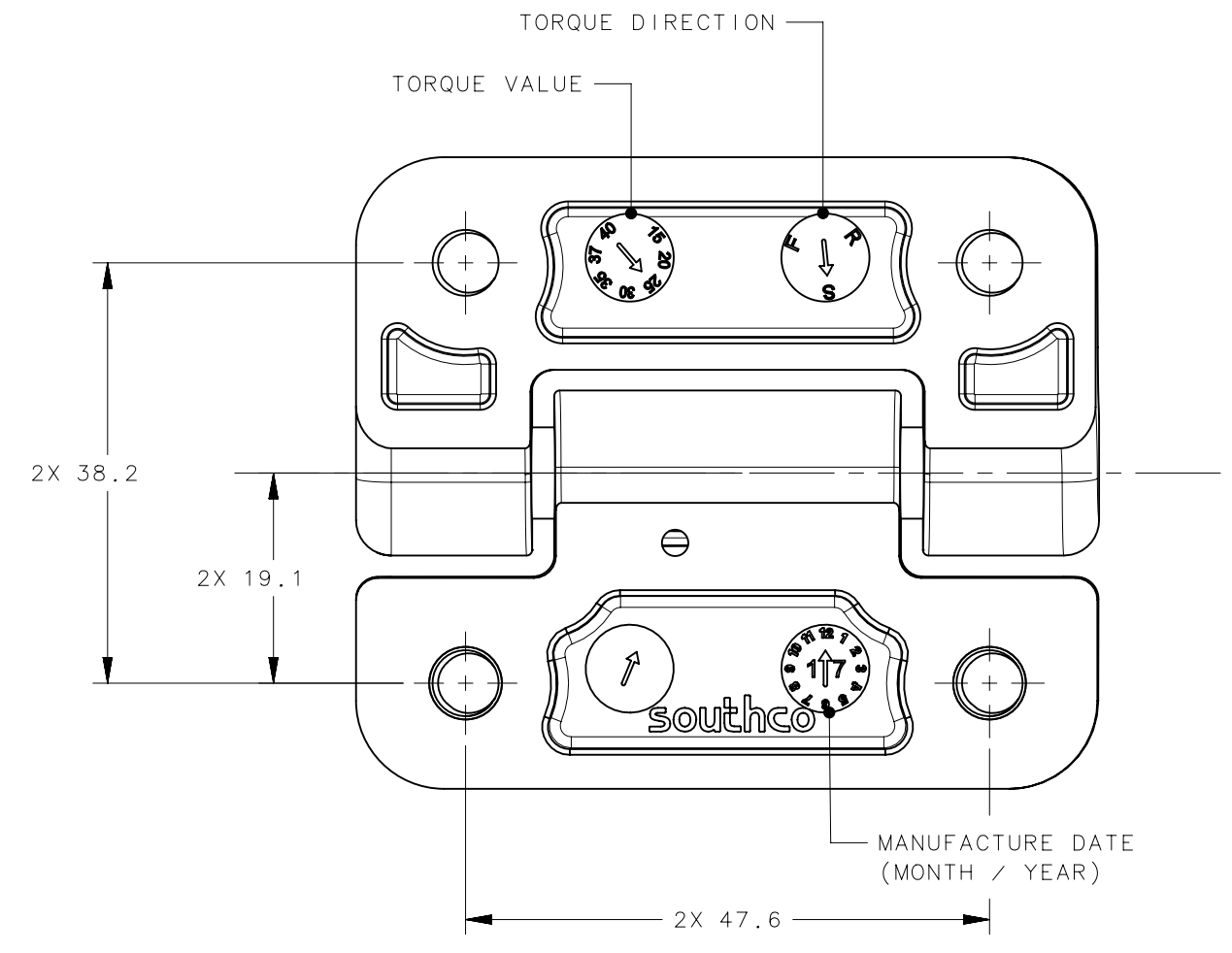
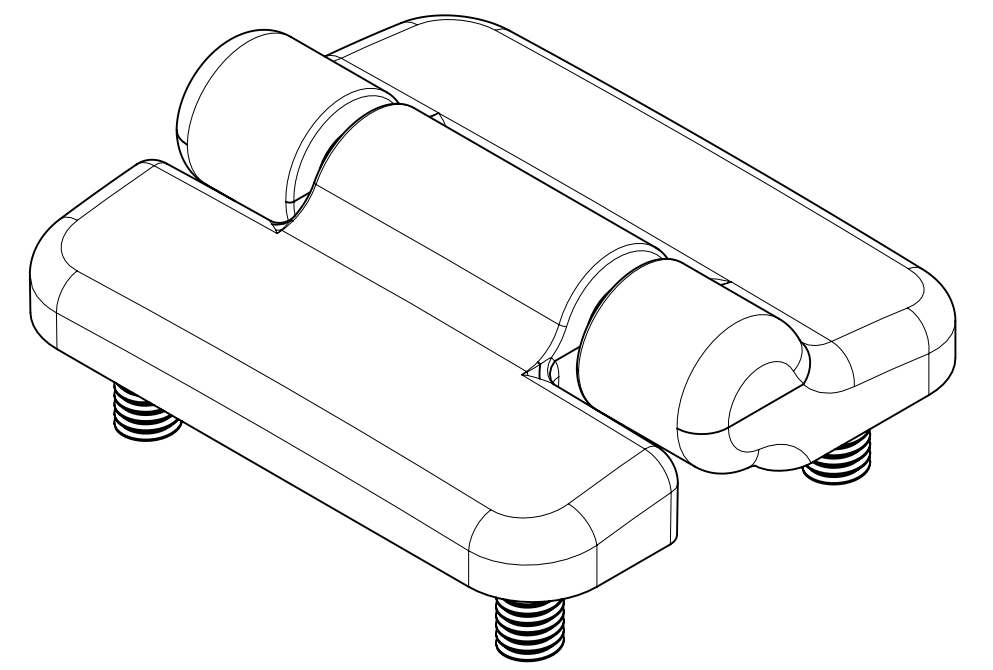
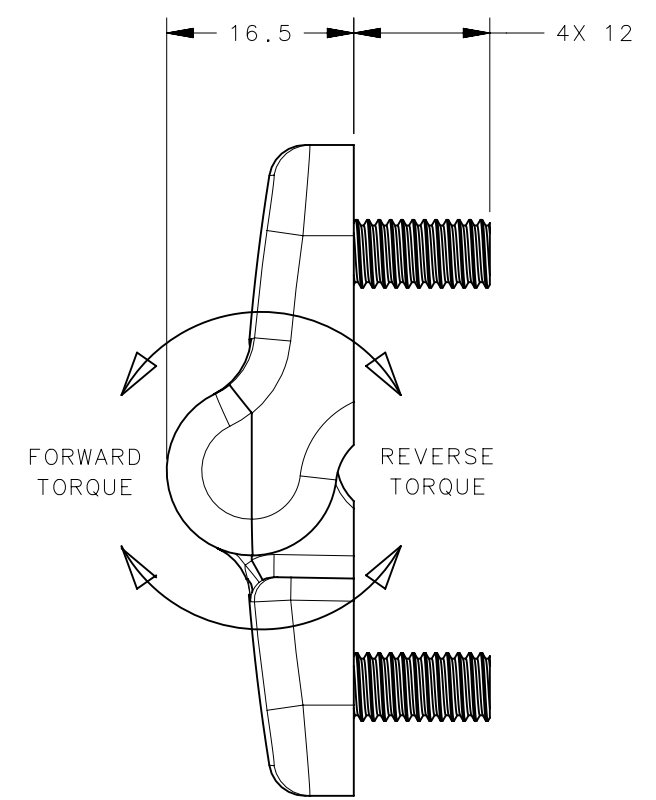
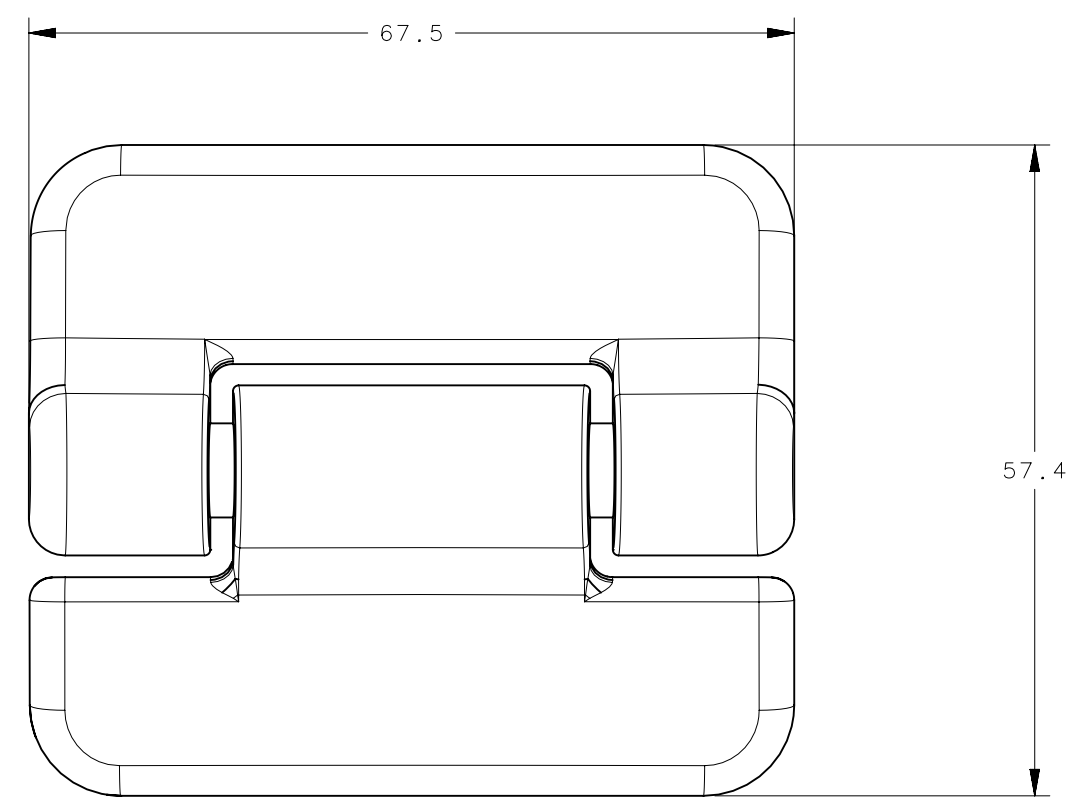

FINISH	
-ZZ	MATERIAL, COLOR
E6-50-5XXX-10	NYLON, WHITE
E6-50-5XXX-20	NYLON, BLACK

PART NUMBER	FORWARD TORQUE, Nm (in-lbf)	REVERSE TORQUE, Nm (in-lbf)
E6-55-535S-ZZ	3.95 (35)	
E6-55-530S-ZZ	3.39 (30)	
E6-55-525S-ZZ	2.82 (25)	
E6-55-520S-ZZ	2.26 (20)	
E6-55-515S-ZZ	1.69 (15)	
E6-55-540F-ZZ	4.52 (40)	3.16 (28) REF
E6-55-535F-ZZ	3.95 (35)	2.77 (24.5) REF
E6-55-530F-ZZ	3.39 (30)	2.37 (21) REF
E6-55-525F-ZZ	2.82 (25)	1.98 (17.5) REF
E6-55-520F-ZZ	2.26 (20)	1.58 (14) REF
E6-55-515F-ZZ	1.69 (15)	1.19 (10.5) REF
E6-55-540R-ZZ	3.16 (28) REF	4.52 (40)
E6-55-535R-ZZ	2.77 (24.5) REF	3.95 (35)
E6-55-530R-ZZ	2.37 (21) REF	3.39 (30)
E6-55-525R-ZZ	1.98 (17.5) REF	2.82 (25)
E6-55-520R-ZZ	1.58 (14) REF	2.26 (20)
E6-55-515R-ZZ	1.19 (10.5) REF	1.69 (15)

- NOTES:
- PERFORMANCE TORQUE TOLERANCE ±20% OVER 20,000 CYCLES
  - THREADED STUDS: M6X1.0 THREAD
  - MATERIAL AND FINISH:  
HINGE LEAVES AND HOUSING: SPECIAL NYLON BLEND  
THREADED STUDS: STAINLESS STEEL  
INTERNAL COMPONENTS: ZINC AND HARDENED STEEL  
BUSHINGS: ALUMINUM
  - SHOWN IN SHIPPING POSITION.
  - RoHS COMPLIANT

THIRD ANGLE PROJECTION	
MILLIMETERS [IN]	
TOLERANCES UNLESS OTHERWISE NOTED	
DESCRIPTION: E6-500 OVERMOLDED HINGE	
SIZE: C	SYSTEM: NX
DWG NO.: J-E6-55-500	
PER ASME Y14.5M-1994	SCALE: 1.5:1
DRAWN BY: JJT	SHEET: 1 OF 1
DATE: 12OCT2016	