

Rotary Units

VEE-RU 55x82 60 QCM

Part no.:10.01.36.00118

<https://www.schmalz.com/10.01.36.00118>

Homepage > Vacuum Technology for Automation > Vacuum Components > Area Gripping Systems and End Effectors > Vacuum End Effectors

VEE > Rotary Units VEE-RU > VEE-RU 55x82 60 QCM

Rotary unit



External diameter D1: 55 mm

Length L1: 82 mm

Nominal flow rate: 60 m³/h

Pitch diameter D mk: 46 mm

Design Data

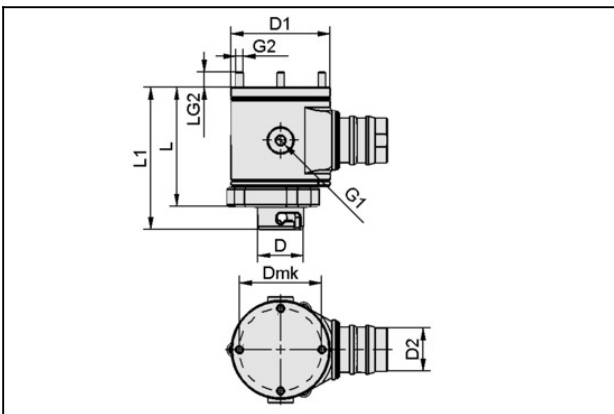

| Attribute | Value |
|-----------|---------|
| Dmk | 46 mm |
| G1 | G1/8"-F |
| G2 | M4-M |
| LG2 | 7.7 mm |
| L | 70.5 mm |