

# Rotary Units

## VEE-RU 55x65 60 FL

Part no.:10.01.36.00065

<https://www.schmalz.com/10.01.36.00065>

Homepage > Vacuum Technology for Automation > Vacuum Components > Area Gripping Systems and End Effectors > Vacuum End Effectors

VEE > Rotary Units VEE-RU > VEE-RU 55x65 60 FL

### Rotary unit



External diameter D1: 55 mm  
 Length L1: 65 mm  
 Nominal flow rate: 60 m<sup>3</sup>/h  
 Pitch diameter D mk: 46 mm

### Design Data

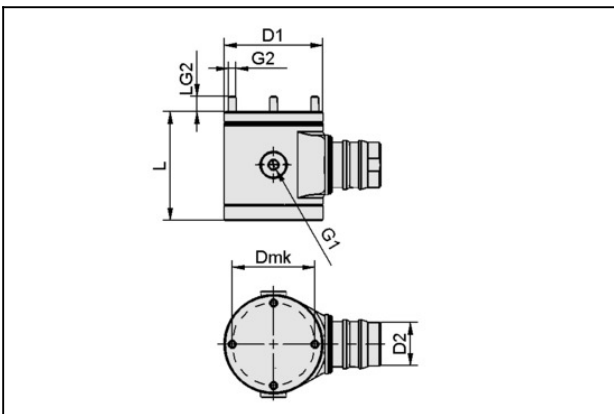

Attribute	Value
Dmk	46 mm
G1	G1/8"-F
G2	M4-M
LG2	7.7 mm
L	65 mm