

### Profile

- Stainless steel hollow shaft up to max.  $\varnothing 20$  mm, feather key groove with  $\varnothing 14$  mm
- "manual" traveling without control unit by means of operator keys
- Brushless 160 W, 24 V DC motor with long service life
- Integrated absolute position encoder on the output shaft
- Integrated positioning controller
- Integrated spring-operated brake (option)
- 2-line LCD for target and position value and operating keys
- Integrated Industrial-Ethernet-Fieldbus
- M12 component mounting technology
- Manual emergency adjustment with motor without brake

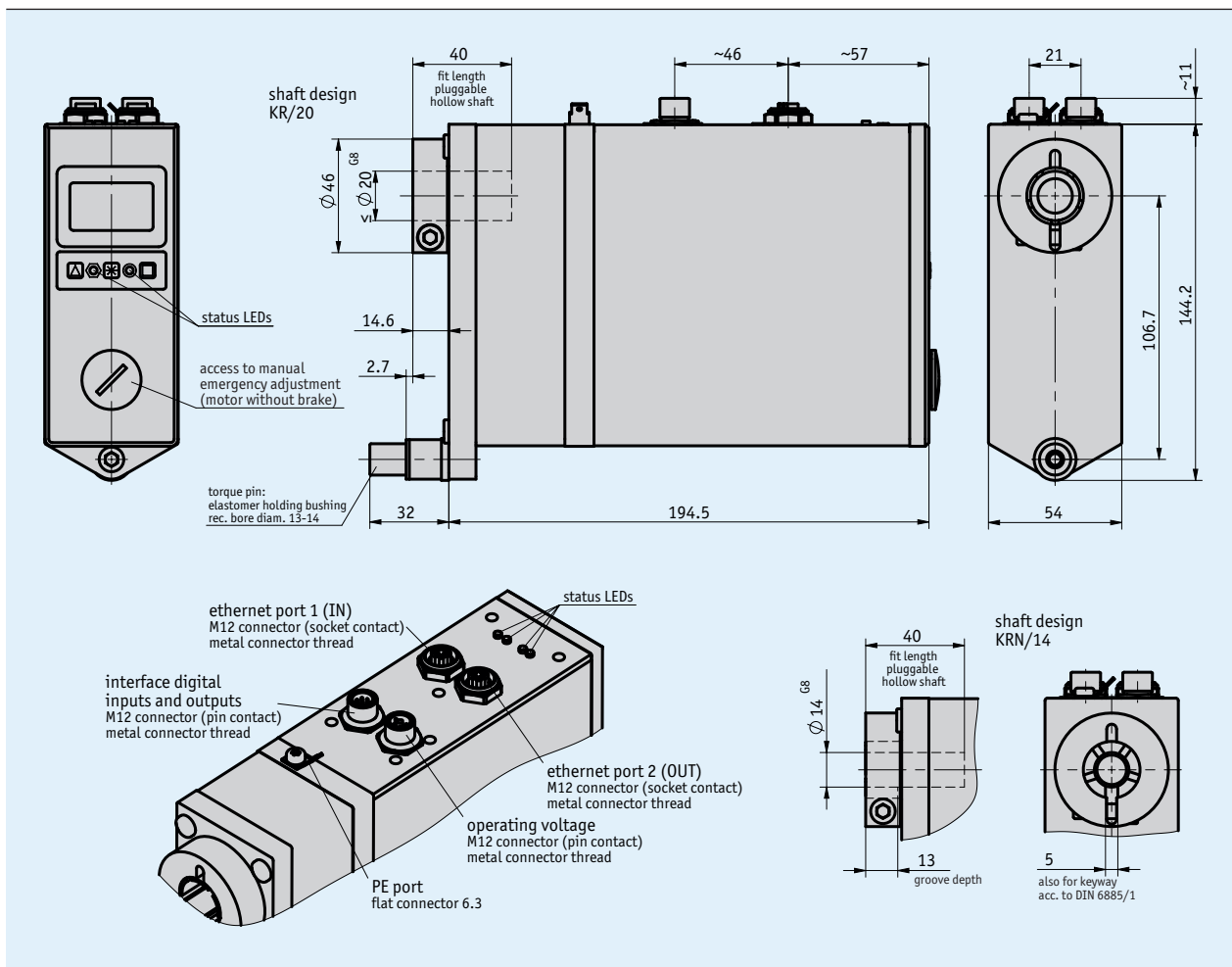

## Mechanical data

Feature	Technical data	Additional information
Shaft	stainless steel	
Housing	aluminum anodized	
Clamping ring	stainless steel	
Nominal torque/rated speed	6 Nm at 150 rpm ( $\pm 10\%$ )	i = 30.6
	10 Nm at 90 rpm ( $\pm 10\%$ )	i = 50
	14 Nm at 64 rpm ( $\pm 10\%$ )	i = 70.8
Operating mode	S3 intermittent duty: 25 % DC, 10 min.	EN 60034-1
Brake momentum	brake-induced stop momentum corresponds at least to the nominal torques of the individual transmissions.	at ambient temperature = 20 °C
Weight	~3.2 kg	

## Electrical data

Feature	Technical data	Additional information
Operating voltage	24 V DC $\pm 20\%$	reverse polarity protected, output stage + control unit
Power input	~160 W	
Rated current	6 A $\pm 5\%$	at rated torque/speed (output stage)
No-load current	350 mA $\pm 20\%$	(with transmission)
Display/display range	6-digit LCD 14-segment, ~8 mm height	decimal points, 2 lines, special characters (LED backlit red/white)
Status display	6 LEDs	
Keys	configuring, inching operation, setting of the IP address	
Bus connection	EIP-EtherNet/IP EPN-PROFINET ECT-EtherCAT EPL-POWERLINK	
Type of connection	1x M12 plug connector (A-coded)	8-pole, 1x pin
	1x M12 plug connector (T-coded)	4-pole, 1x pin
	2x M12 plug connectors (D-coded)	4-pole, 2x socket
	grounding via flat connector 6.3 mm	

## System data

Feature	Technical data	Additional information
Resolution	1024 steps/revolution shaft	singleturn / 10 bit
Travel range	4096 revolution(s)	12 bit multiturn (rounded)

## Ambient conditions

Feature	Technical data	Additional information
Ambient temperature	0 ... 45 °C	
Storage temperature	-20 ... 80 °C	
Relative humidity		condensation inadmissible
EMC	EN 61800-3, second environment	interference resistance / immission
	EN 61800-3, C2	emitted interference / emission
Protection category	IP54, IP65	EN 60529, mating connectors mounted
Shock resistance	$\leq 500 \text{ m/s}^2$ , 11 ms	EN 60068-2-27, half-sine, 3 axes (+/-), each 3 shocks
Vibration resistance	$\leq 100 \text{ m/s}^2$ , 10 ... 55 Hz	EN 60068-2-6, 3 axes, each 10 cycles

### Pin assignment

■ EtherCAT, EtherNet/IP, POWERLINK, PROFINET

Signal	PIN
Tx+	1
Rx+	2
Tx-	3
Rx-	4

■ Digital inputs / outputs

Signal	PIN
Input 1	1
Input 2	2
Input 3	3
Input 4	4
Output 1	5
RXD	6
TXD	7
SGND*	8

\* internally connected with GND of operating voltage

■ Operating voltage (output stage / control)

Signal	PIN
+UB (output stage)	1
+UB (control)	2
GND (output stage)*	3
GND (control)*	4

\* internally connected with SGND

### Performance curve

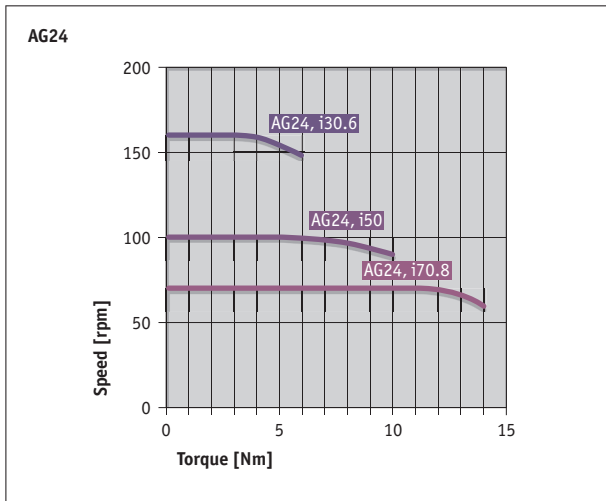

### Order

#### Ordering table

Feature	Ordering data	Specification	Additional information
Gear ratio	70.8	i = 70.8	
	50	i = 50	
	30.6	i = 30.6	
		others on request	
Motor/brake	160W/MB	160 W EC motor with brake	
	160W/OB	160 W EC motor without brake	
Protection category	IP54	IP54	
	IP65	IP65	
Shaft design/diameter	KR/20	Clamping ring, ø20 mm	
	KRN/14	Clamping ring and feather key groove, ø14 mm	
		others on request	
Interface/protocol	EIP	EtherNet/IP	
	EPN	PROFINET	
	ECT	EtherCAT	
	EPL	POWERLINK	

#### Order key

AG24 Fieldbus/IE -   -   -   -   -   - S

A
B
C
D
E

**Scope of delivery:** AG24 Fieldbus/IE, Quick Start Guide

#### Accessories:

Cable extension KV08S2

[www.siko-global.com](http://www.siko-global.com)

Programming software ProTool DL

[www.siko-global.com](http://www.siko-global.com)

Mating Connector Overview

[www.siko-global.com](http://www.siko-global.com)

Mating connector, digital inputs/outputs, 8-pole, socket

Order key 83525

Mating connector, digital inputs/outputs, 8-pole, angle socket

Order key 87599

Mating connector, port 1 + port 2, 4-pole, pin

Order key 87601

Mating connector, port 1 + port 2, 4-pole, angular pin

Order key 87600

Mating connector, operating voltage, 4-pole, socket

Order key 89115