

### Profile

- Low-cost and compact turning handle made of glass-fiber reinforced plastic
- Various sizes
- Surface with rounded edges avoids accumulation of dirt
- Hub made of plastic or metal
- Various hub versions

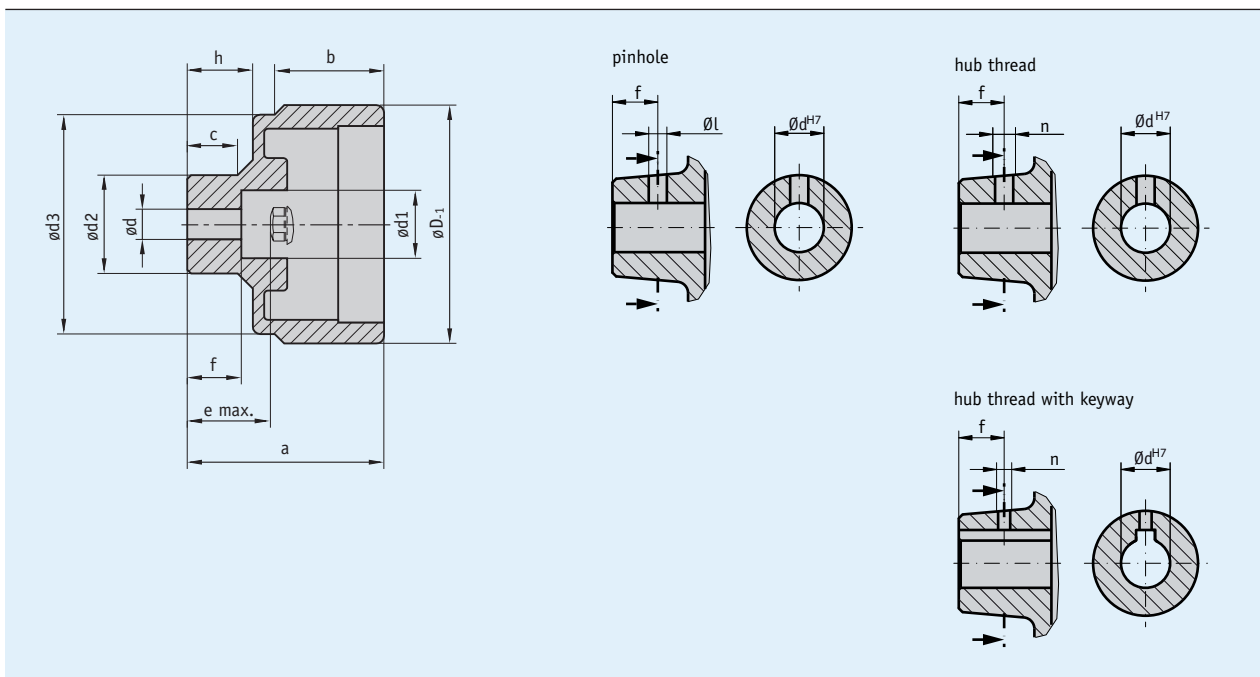

### Mechanical data

Feature	Technical data	Additional information
Material	plastic	
Weight	0.1 kg	HG5
	0.2 kg	HG10

### Table of dimensions

Type	Hub	øD	ødv	ødx	ød1	ød2	ød3	a	b	c	e	f	h	Suitable for
HG5	synthetic	63		6 ... 12 <sup>H9</sup>	13	21	58	49	28.9	14.3	19.2	17.2	14.3	S50/1
	metal	63	5.8	6 ... 14 <sup>H7</sup>	18	26	58	52	28.9	13.3	22.2	14.3	17.3	S50/1
HG10	synthetic	98		6 ... 16 <sup>H9</sup>	16	30	93	56	31.5	18.7	22.8	20.7	18.7	S80/1; SZ80/1
	metall	98	5.8	6 ... 16 <sup>H7</sup>	25.5	35	93	59	31.5	18.2	25.8	18	21.7	S80/1; SZ80/1

ødv = d prebored

■ **Special treatment**

Handwheel type	HG5				HG10			
	6, 8	9, 10	12	14*	6 ... 8	9, 10	11, 12	13 ...16
Bore dH7								
Groove width with keyway JS9		3	4	5		3	4	5
Pin hole	3.8/10	3.8/10	3.8/10	4.8/10*	3.8/10	3.8/10	3.8/10	4.8/10
Hub thread without keyway JS9	M4/10	M4/10	M4/10*	M6/10*	M4/10	M4/10	M4/10	M6/10
Hub thread with keyway JS9	M3/10	M3/10	M3/10			M3/10	M3/10	M4/10

\* possible with metal hub only; **Texts highlighted in orange color are ordering features**

## Order

### Ordering information

One or more system components are required:

Analog position indicator S50/1

[www.siko-global.com](http://www.siko-global.com)

Analog position indicator S80/1

[www.siko-global.com](http://www.siko-global.com)

Analog position indicator SZ80/1

[www.siko-global.com](http://www.siko-global.com)

### Ordering table

Feature	Ordering data	Specification	Additional information
handwheel type	5	HG5	
	10	HG10	
Hub material	A	aluminium	
	K	plastic	
	VA	stainless steel	
Bore diameter	5.8	prebored	
	...	6 ... 16 mm, in steps of 1 mm	see Table of dimensions, maximum value ødx
Feather key groove	OP	without keyway	
	JS9	light seat	according to DIN 6885/1 T1, only with hub material "VA" or "A"
	P9	tight fit	according to DIN 6885/1 T1, only with hub material "VA" or "A"
Pinhole	OS	without pin hole	
	...	diameter "ø"/measure "f" (e.g. 3.8/10)	see table Special processing, depending on the handwheel type, only if keyway is "OP", only if hub thread is "ONG"
		others on request	
Hub thread	ONG	without hub thread	
	...	thread "n"/measure "f" (e.g. M4/10)	see table Special processing, depending on the handwheel type, only if pin hole is "OS", only with hub material "VA" or "A"
		others on request	
Tapered hub	OAN	without turned hub	
		others on request	
Position indicator	PM	position indicator mounted	separate ordering of a position indicator required!
	PS	position indicator separate	separate ordering of a position indicator required!

### Order key



Scope of delivery: HG...

Accessories:  
End Plate AD

[www.siko-global.com](http://www.siko-global.com)