

REV.	DATE	BY-CHKD	REVISIONS	PART NUMBERING TABLE						
				PART No.	ø"A"	ø"B"	"C"	"D"	"R"	DESCRIPTION
A	14MAY2002	KHO DLH	PRN: P2002-0209	47-04	.250	.121	.140	.218	.020	No.4 AND M3 THREADS
B	21JUL2008	ACH MJS	PRN: P2008-0806	47-05	.400	.200	.224	.348	.032	M5 THREADS
C	14MAY2009	ACH MJS	PRN: P2009-0604	47-06	.300	.141	.168	.264	.025	No.6 AND M3.5 THREADS
				47-08	.400	.167	.224	.348	.032	No.8 AND M4 THREADS
				47-10	.400	.193	.224	.348	.032	No.10 THREADS
				47-25	.500	.253	.280	.434	.040	1/4 AND M6 THREADS

MATERIAL: AISI A-2
 FINISH: NATURAL
 HEAT TREAT: HRC 56-60

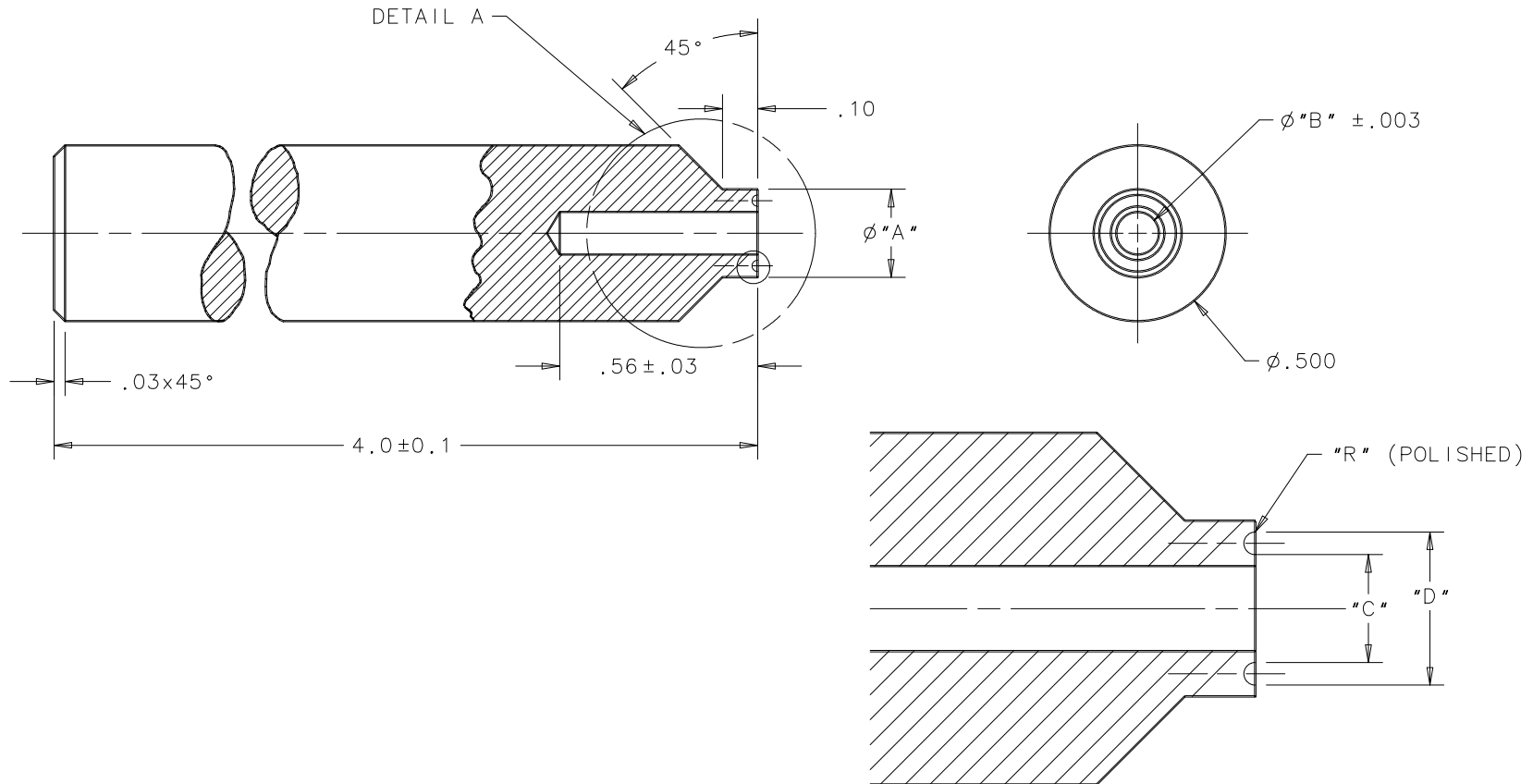

DETAIL A
 SCALE 4:1

FORMAT A 3/88

PROPRIETARY ITEM - EXCEPT FOR USES EXPRESSLY GRANTED IN WRITING
 INFORMATION DISCLOSED HEREON IS CONFIDENTIAL AND ALL RIGHTS PATENT
 AND OTHERWISE ARE RESERVED BY SOUTHCO, INC.

DIMENSIONS ARE IN INCHES
 ALL DIMENSIONS WITHOUT TOLERANCES ARE REFERENCE.
 THIRD ANGLE PROJECTION

DRAWING NUMBER
 J-47-04